

BNSF Intermodal Loading Guide

Revised 2019



LARS Field Territories



NORTHWEST

Denver, CO
Eileen McRae* (303) 408-7926

Seattle, WA
Jason Yarger (206) 658-1665

Portland, OR
Elliott Zajac (360) 418-6495

SOUTHWEST

San Bernardino, CA
Al Aguiniga* (909) 386-4480
Courtney Green (909) 386-4125

Los Angeles, CA
Juan Lopez (323) 267-4060

Stockton, CA
John Brainard (209) 460-6061
Russ Cole (209) 460-6184

PRODUCT RECOVERY TEAM

Topeka, KS
Lonnie Walker* (785) 435-2496
Pete Killman (785) 435-3545

AUTOS / RIDE QUALITY

Fort Worth, TX
Seth Cosby* (817) 352-2710
Khoa Do (817) 352-2706

NORTHEAST

Chicago, IL
George Hogle* (815) 424-2273
Mike Detrick (708) 482-5144
Nic Esquivel (815) 424-2230
Jeff Davis (773) 579-5032

SOUTHEAST

Kansas City, KS
Luke Rothwell* (913) 551-4429
Juan Acevedo (913) 551-4317

Memphis, TN
Jeremiah McCroskey (901) 433-4632

Houston, TX
Bryan Echols (713) 847-3493

OPEN TOP LOADS

Kansas City, KS
Scott VanGosen* (913) 551-4614
Tim Neal (913) 551-4509

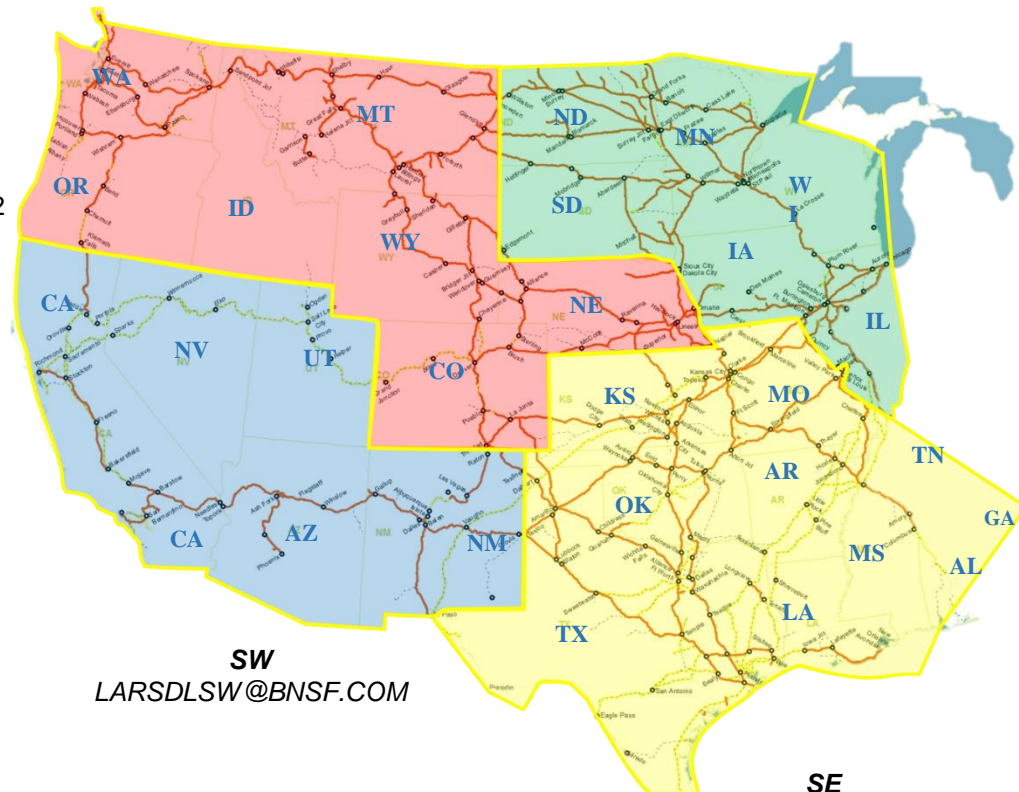
Chicago, IL
Bob Coulter (815) 424-2129

* = Sr. Manager

Howard Rosas – General Director – (817) 352-2703
Joe Giacoppi– Director North– (817) 352-2721
Jeff Carter – Director South– (817) 352-2975

NW
LARSDLNW@BNSF.COM

NE
LARSDLNE@BNSF.COM



SW
LARSDLSW@BNSF.COM

SE
LARSDLSE@BNSF.COM



TABLE OF CONTENTS

SECTION I	General Information
SECTION II	Trailer/Container Inspection Procedures
SECTION III	TOFC/COFC Physical Environment
SECTION IV	Loading, Blocking and Bracing of Intermodal Loads
SECTION V	Security Seals
SECTION VI	Dunnage and Unitizing Materials
SECTION VII	BNSF Approved Methods
	1. Rear Door Method
	2. Cased Goods (Food and Beverage)
	3. Paper (Rolls and Flat Stock)
	4. Scrap Metal
	5. Drum Loading
	6. Logs
	7. Bagged Product
	8. Machinery and Fork Lift Trucks
	9. Ceramic Tile
	10. Flexi-Tanks (Bulk Bladders)
	11. Lumber – Plywood
	12. Supersack Loading
	13. LTL Planning and Loading
SECTION VIII	Hazardous Materials

SECTION I



General Information

GENERAL INFORMATION

As a shipper on BNSF, you've selected the number one intermodal carrier in the industry – both in volume and commitment. At BNSF, we are committed to meeting the various challenges of the future. Our number one priority is the safety of our employees, the communities through which we operate, and the cargo that is entrusted to us by our customers.

“Our vision is to realize BNSF’s tremendous potential by providing transportation services that consistently meet our customers’ expectations.”

SAFE LOADING

While BNSF goes to great lengths to provide top-notch service for our customers, should a load shift occur due to inadequate securement or if the cargo was loaded with improper weight distribution at origin, the vehicle may lean excessively on the flatcar.

A leaning vehicle, because of its high center of gravity, can actually fall from the flatcar or cause flatcar wheels to rise from the track, either of which can result in a serious derailment. Cargo moving against vehicle doors can break door locking mechanisms, allowing doors to open and Cargo to fall from the vehicle. Either of these instances can cause personal injury, as well as damage to both equipment and your products.

EN ROUTE SET OUT OF DISTRESSED LOAD

While in transit, if the vehicle is observed leaning or with distressed doors, the train may be stopped and the railcar set out for adjustment or any necessary handling. This results in delays to other shipments moving on the train, as well as your shipment. This publication has been developed to help prevent such incidents. By following basic rules of tight loading, proper weight distribution and proper securement adequate blocking and bracing, your load will arrive safely and damage free.

If you are a new customer, have a loading problem or an alternative loading method for evaluation; contact your local Load And Ride Solutions (LARS) Manager. To obtain further information, please refer to the BNSF Rules and Policies Guide or your BNSF Marketing Account Manager.

SECTION II



Trailer/Container Inspection Procedures

EXTERIOR EQUIPMENT INSPECTION

The exterior inspection should include these items:

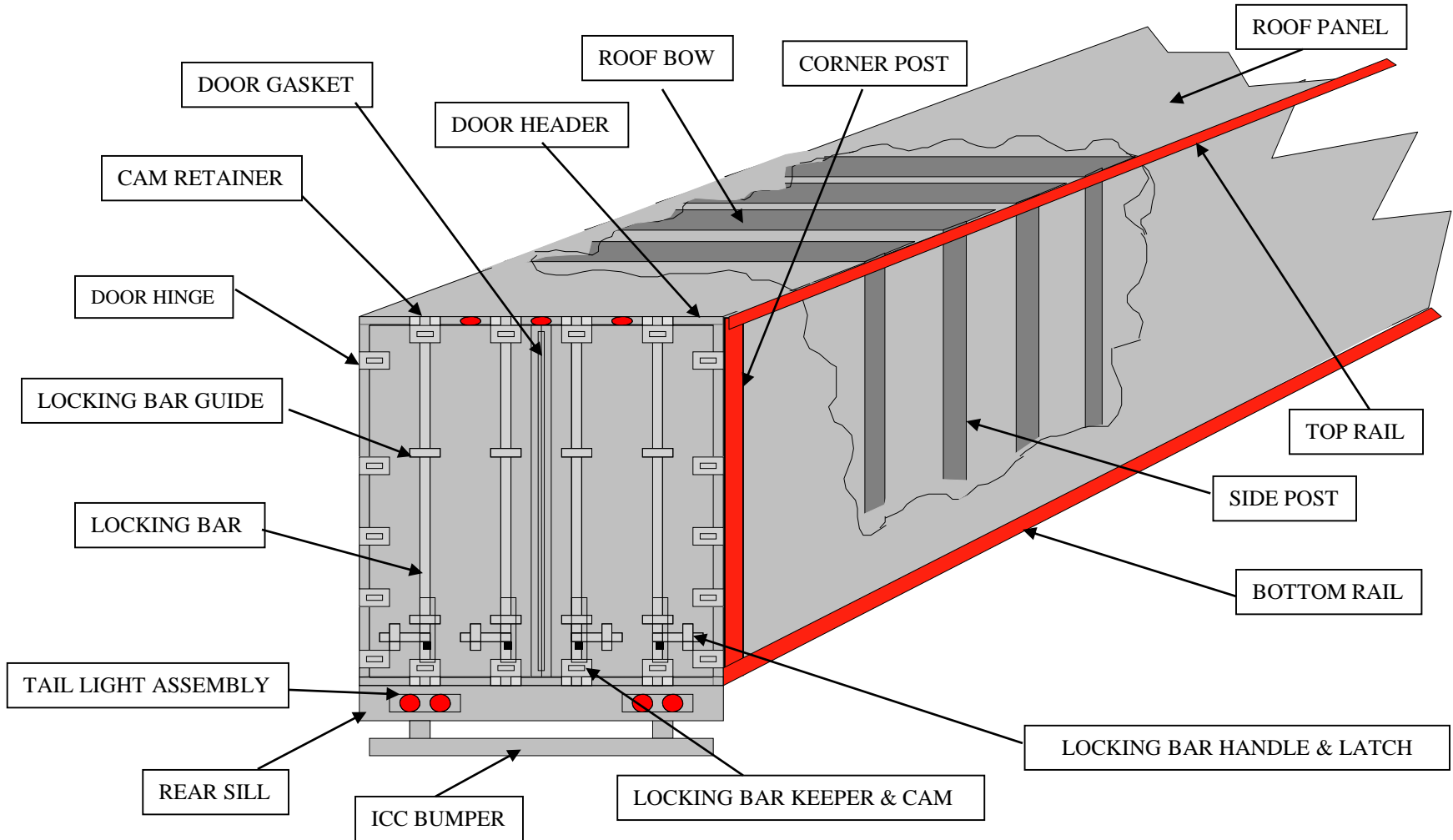
- 1) Check safety appliances to ensure compliance with highway regulations.
- 2) Check for defects that could affect properly closing the doors, such as bent or broken doors, damaged or missing weather seals, defective locking hardware, etc.
- 3) Inspect equipment walls, roof panels, top rail and undercarriage for soundness and holes, cuts, bends, dents or other defects which could compromise the equipment and contents.

INTERIOR EQUIPMENT INSPECTION

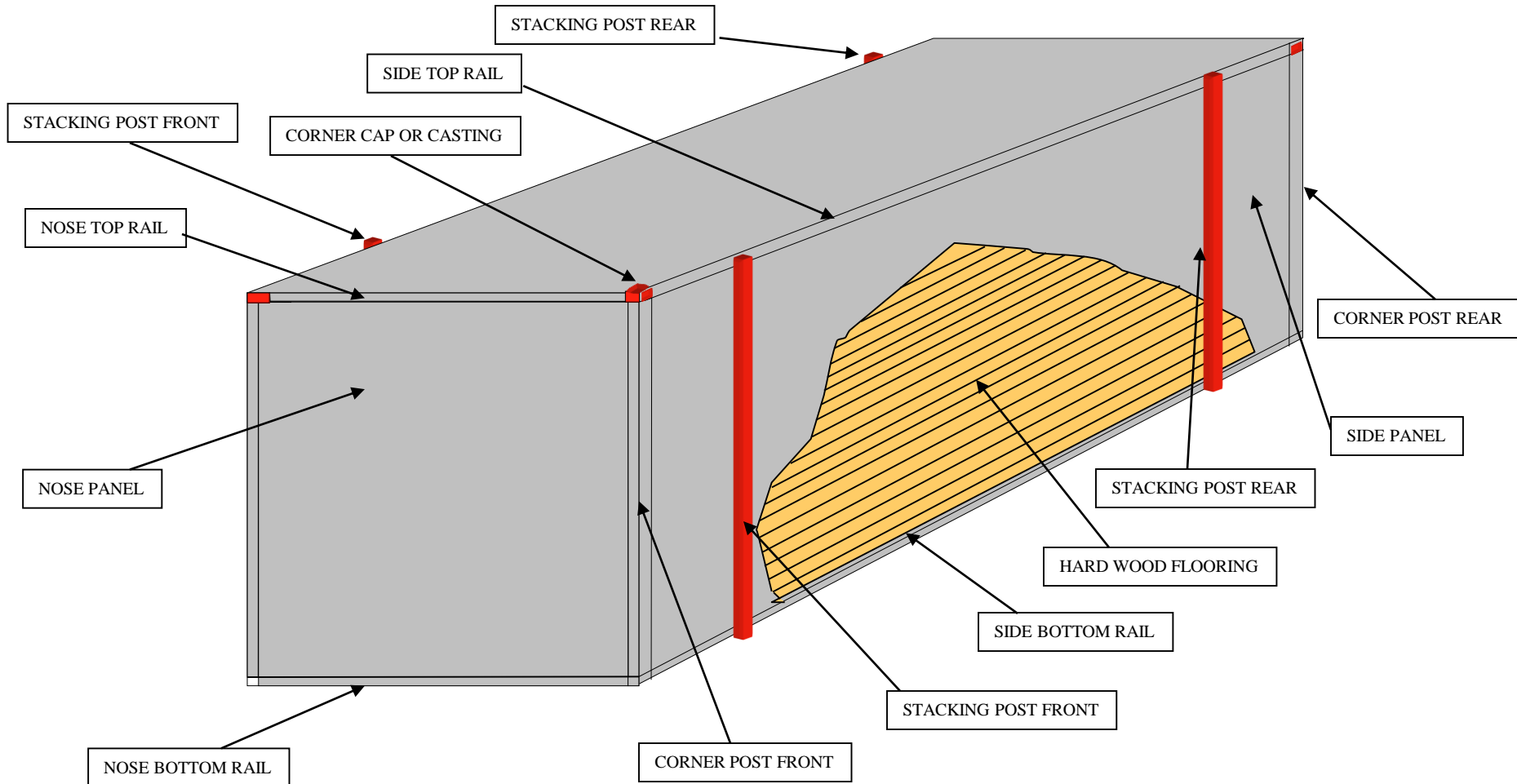
The interior inspection should include the following:

- 1) Checking for foreign materials or odors which might be contaminate your products.
- 2) Check wall and door linings for broken or missing panels, and for nails, staples or any other protrusions which could contact lading and cause damage to your cargo. If any such defects are found, you may elect to cover the defective area(s) with corrugated fiberboard or other suitable material, remove protruding objects, or reject the equipment for loading.
- 3) Inspect the floor for soundness, particularly where bracing materials will be nailed to ensure the nail's maximum holding power. Remove any exposed nails or protrusions. Sweep the vehicle floor before loading to minimize dust settling on the cargo during transit.
- 4) Checking for leaks. If your product is susceptible to damage from the elements, get inside the unit and have the doors securely closed. If any light enters, so can moisture, air and dust. After dark, check by using a spotlight outside the unit and along all seams. If defects are found, reject the unit for loading.

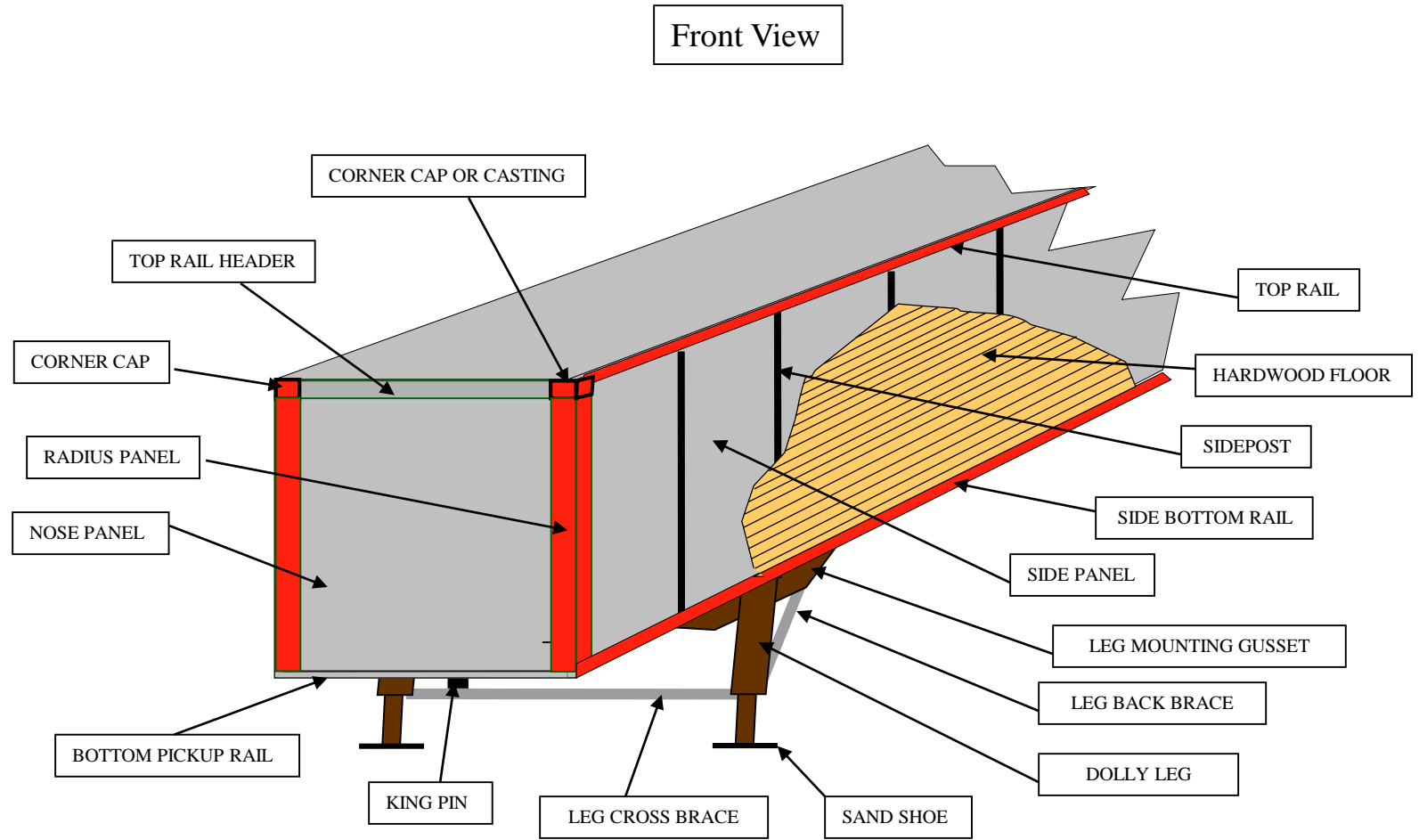
PROPER INTERMODAL REPORTING AND TERMINOLOGY



PROPER INTERMODAL REPORTING AND TERMINOLOGY



PROPER INTERMODAL REPORTING AND TERMINOLOGY



SECTION III



TOFC/COFC Physical Environment

THE RAIL ENVIRONMENT

Intermodal customers should be aware of the physical forces that affect the load during transit. Since the shipment will travel by truck, rail, and possibly water or air modes, the individual operations and physical characteristics of each mode should be considered, as well as the combined effects. By understanding the forces affecting each shipment in various modes, the most effective packaging, load planning, blocking and bracing for safe arrival can be realized.

Vibrations and shock are two forces encountered in transport. The forces occur continuously (vibration, a result of an object oscillating) as isolated incidents (shock, a result of an abrupt change in acceleration and direction) or simultaneously, which results in very complex dynamic forces. These forces generally occur in three directions: vertical, longitudinal and lateral.

Failure to control (dampen) these elements can jeopardize the safe transportation of the load, as well as the entire train. Improperly loaded freight or inadequate bracing can produce the following situations:

1. Load movement to one side of the unit, causing it to lean excessively on the flatcar.
2. Load movement through the ends of the equipment.
3. Collapsed vehicle floors (from concentrated weight of high-density commodities or poor condition of equipment).

Any of these situations can cause cargo damage from compression; damage to equipment doors, walls or floor; or cause a train derailment.

THE HIGHWAY ENVIRONMENT

Vibration in the vertical direction is considered most severe in the highway environment. This is a result of the truck's suspension system having a natural response in a low-frequency range. When the vehicle tires contact the highway surface, a continuous vertical vibration input (forcing frequency) is produced. Uneven surfaces, such as holes, bridge abutments or grade crossings, produce vertical shocks, which also produce vertical vibrations. When the forcing frequency coincides with the natural frequency of the suspension system, amplification of the forces occur. At times, these amplified forces can reach such magnitude that even high-density lading will move, often necessitating a load adjustment.

Lateral forces generated from traversing uneven roadway surfaces are normally less severe than vertical vibration. Longitudinal shocks, encountered in the highway mode during starting and stopping in traffic, or backing into a dock, are generally greater, as those experienced in the rail mode.

The optimal ride quality is found in the center portion of the vehicle, followed by the nose portion and then the rear area.

SECTION IV



Loading, Blocking and Bracing of Intermodal Loads

LOADING, BLOCKING AND BRACING INTERMODAL LOADS

When shipping intermodal on the BNSF, the shipper has certain obligations to safely load contents, as stated in The BNSF Intermodal Rules & Policies Guide. These obligations are:

Maximum Weights: In no instance can the maximum gross weight of the equipment (container, trailer or container on chassis) and cargo (loading) exceed: 52,900 lbs. for a 20 foot container; 58,000 lbs. for a coiled metal or tank container shipment, or for commodities loaded on a BNSF-approved sled or load and roll pallet (LRP); 65,000 lbs. for a trailer or container on chassis; or 67,200 lbs. for a 40 to 53 foot container. Responsibility for adequate packaging, loading, blocking and bracing of the shipment lies entirely with the shipper and BNSF reserves the right to weigh any shipment.

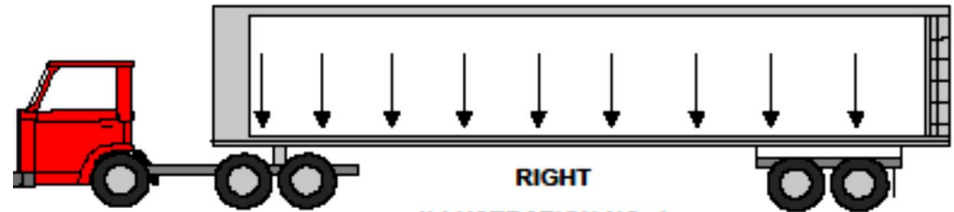
Weight Distribution: Vehicles are designed for uniform load distribution. Cargo weight in vehicles must be evenly distributed both laterally and longitudinally. It must be equally distributed between the rear tires and the kingpin. Cargo is to be secured in such a manner to prevent it from shifting either laterally or longitudinally during transport where it would affect safe weight distribution or position in vehicle.

Weight Concentration: Regardless of the commodity or equipment, the Cargo weight must be distributed evenly over the entire floor surface with no more than 25,000 lbs. in any ten (10) linear feet or 2,500 lbs. per linear foot. To clarify: Extremely concentrated weight (small footprint on the equipment floor; e.g., cylindrical-shaped object) can result in floor failure and must be avoided.

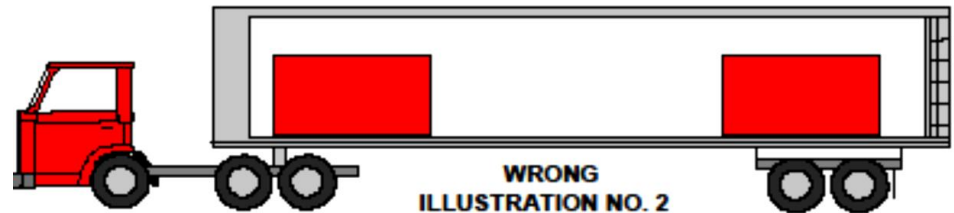
Vehicle Doors: Container or trailer doors are not designed or constructed to restrain longitudinal movement of cargo under normal railroad operating conditions. The cargo must be loaded and restrained adequately to prevent it from exerting excessive pressures against doors, walls or ends of vehicle that might cause their failure.

Proper Load Distribution

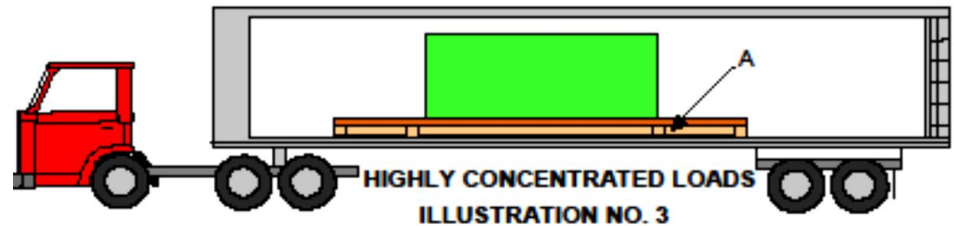
Trailers are designed for uniform load distribution as shown. Distribute the cargo equally between the rear tires and the king pin which transfers its load to the truck tractor.



Units loaded in either position indicated are incorrect because weight is not equally distributed to tires and king pin.



Not more than 25,000 lbs. can be loaded in any 10 linear feet. Item "A" skid of adequate length and construction to properly distribute weight over trailer/container floor.



TOFC trailers are often left unsupported by truck tractors and are lifted by cranes. In positioning two concentrated weight units as illustrated, position the forward unit for equal weight distribution on the landing gear. (Approximately 10 feet from the nose.)



Reinforcement of Lengthwise Blocking to Trailer/Container Floors

Reinforcement of lengthwise blocking placed cross trailer/container can be provided by the use of diagonal blocking to the trailer floor. **DO NOT APPLY THIS BLOCKING AT AN ANGLE GREATER THAN 45 DEGREES WITH THE TRAILER/CONTAINER FLOOR.** If possible, position diagonal at the upper third of the load. (See illustration on the next page).

The table below contains approximate lengths of floor diagonals which will be of such a length that the angle will not exceed 45 degrees.

Height of Application of Diagonal Brace To Minimum
Length of Cross Brace or Load Above Trailer Floor

Diagonal Brace Required

1 Foot - 0 inches
1 Foot - 6 inches
2 Feet - 0 inches
2 Feet - 6 inches
3 Feet - 0 inches
3 Feet - 6 inches
4 Feet - 0 inches
4 Feet - 6 inches
5 Feet - 0 inches
5 Feet - 6 inches
6 Feet - 0 inches

1 Foot – 6 inches
2 Feet – 3 inches
3 Feet – 0 inches
3 Feet – 6 inches
4 Feet – 3 inches
5 Feet – 0 inches
5 Feet – 9 inches
6 Feet – 6 inches
7 Feet – 3 inches
7 Feet – 9 inches
8 Feet – 6 inches

Rear gates may be braced against corner posts where trailers/containers are so constructed. Double miter diagonal members extending to the trailer floor and reinforce by a backup cleat of at least 2" x 4" x 18" wood blocking. Drive nails perpendicular to floor for maximum holding power of nails. (See illustration on the next page).

REAR GATE WITH FLOOR BLOCKING AND KNEE BRACES

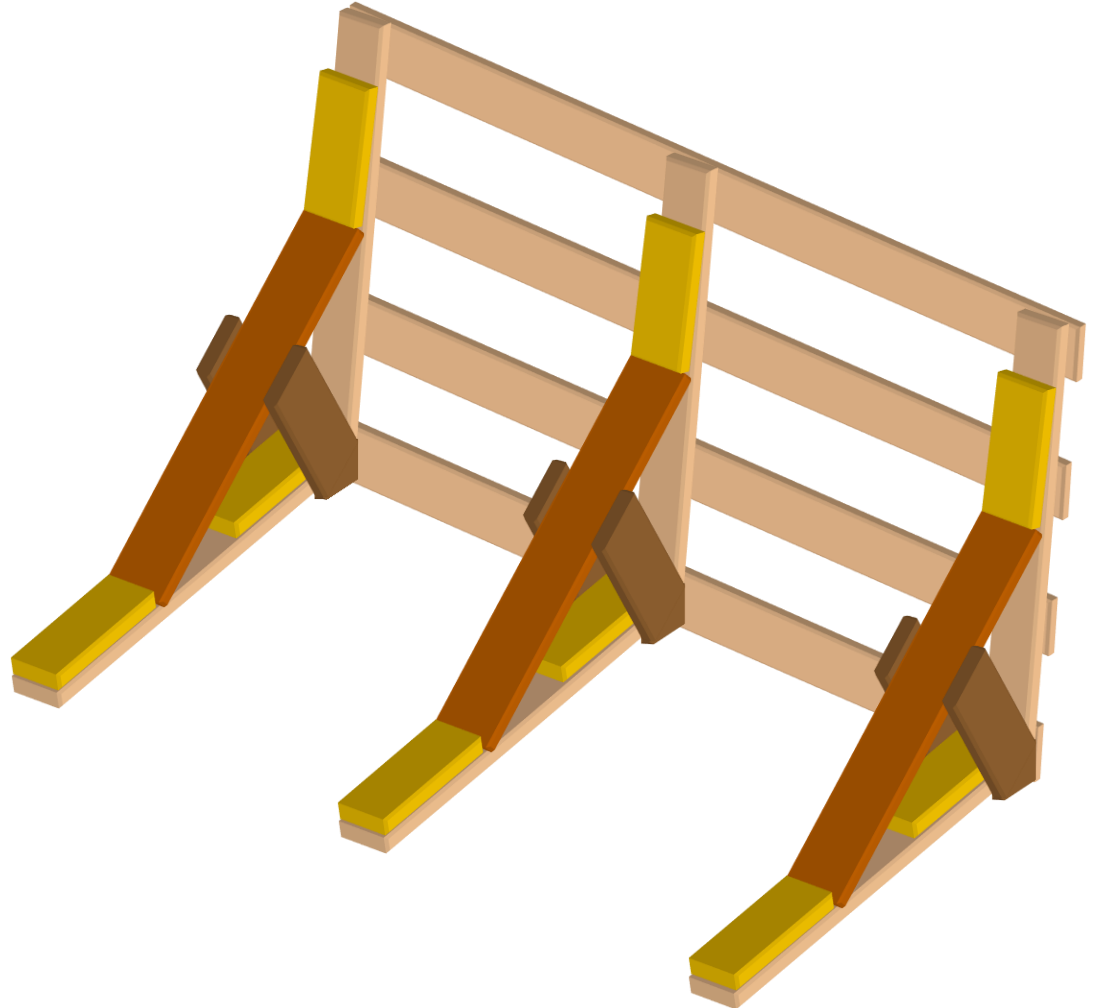
Lengths of Diagonals to Trailer Floor (Feet)
Angle of Floor Diagonals = Apprx. 45°

**HEIGHT OF
 APPLICATION OF
 DIAGONAL BRACE
 TO CROSS BRACE
 OR LOAD ABOVE
 TRAILER FLOOR**

**MINIMUM LENGTH
 OF DIAGONAL
 BRACE REQUIRED**

1	1-1/2
1-1/2	2-1/4
2	3
2-1/2	3-1/2
3	4-1/4
3-1/2	5
4	5-3/4
4-1/2	6-1/2
5	7-1/4
5-1/2	7-3/4
6	8-1/2

**NOTE: DO NOT APPLY DIAGONAL
 BRACE AT AN ANGLE GREATER
 THAN 45° WITH TRAILER FLOOR.**



Floor Blocking Applications

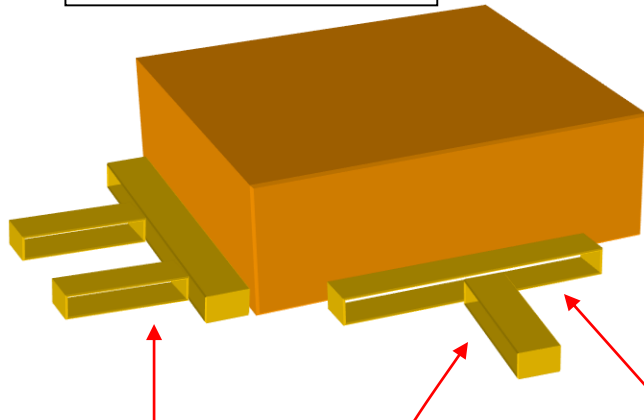
Consider the relation of the number, size and kind of nails to the size and kind of lumber used in floor blocking applications. Use sufficient nails, as the strength of blocking and bracing increases directly with the number and size of nails. Do not use nails where they will be in direct tension, but preferably in lateral resistance as shown in diagrams on the next few pages.

Securely nail to trailer/container floor all floor blocking to prevent lengthwise movement. Reinforce with backup cleats not less than 2" x 4" lumber and at least 18" in length. Stagger nails in an offset pattern every 4 - 6". The size and number of nails required will be dictated by the *weight* of lading.

Use floor blocking as shown in diagrams on the next few pages of not less than 2" x 4" lumber and extend or exceed full width of the boxed or crated item against which it bears to prevent concentrated pressure or shearing of the container. For shipments on skids, use floor blocking of the same thickness as the skid members with backup cleats placed in line with the skid members. Please note that lateral (side) blocking back-up cleats are not always required, but are dependent upon unit weight.

FLOOR BLOCKING AND KNEE BRACES

**LOAD NOT SECURED
TO PALLET/SKID**

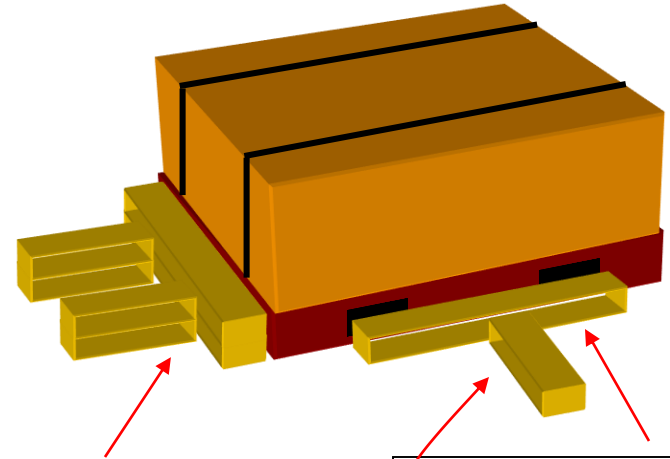


**2" X 4" FLOOR BLOCKING
AND 2" X 4" X 18" BACK-UP
CLEATS (REAR OF LOAD)**

2" X 4" SIDE BLOCKING

**NOTE: DEPENDENT UPON UNIT
WEIGHT, BACK-UP CLEAT (BOTH
SIDES OF LOAD) MAY BE REQUIRED**

**LOAD SECURED
TO PALLET/SKID**

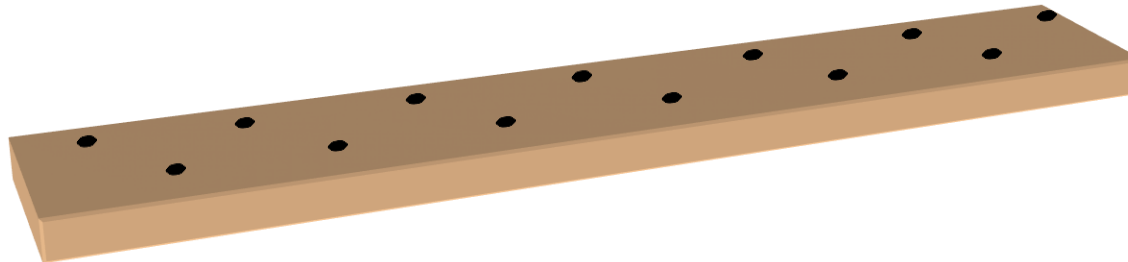


**LAMINATED 2" X 4" FLOOR
BLOCKING AND 2" X 4" X 18"
BACK-UP CLEATS (REAR OF
LOAD)**

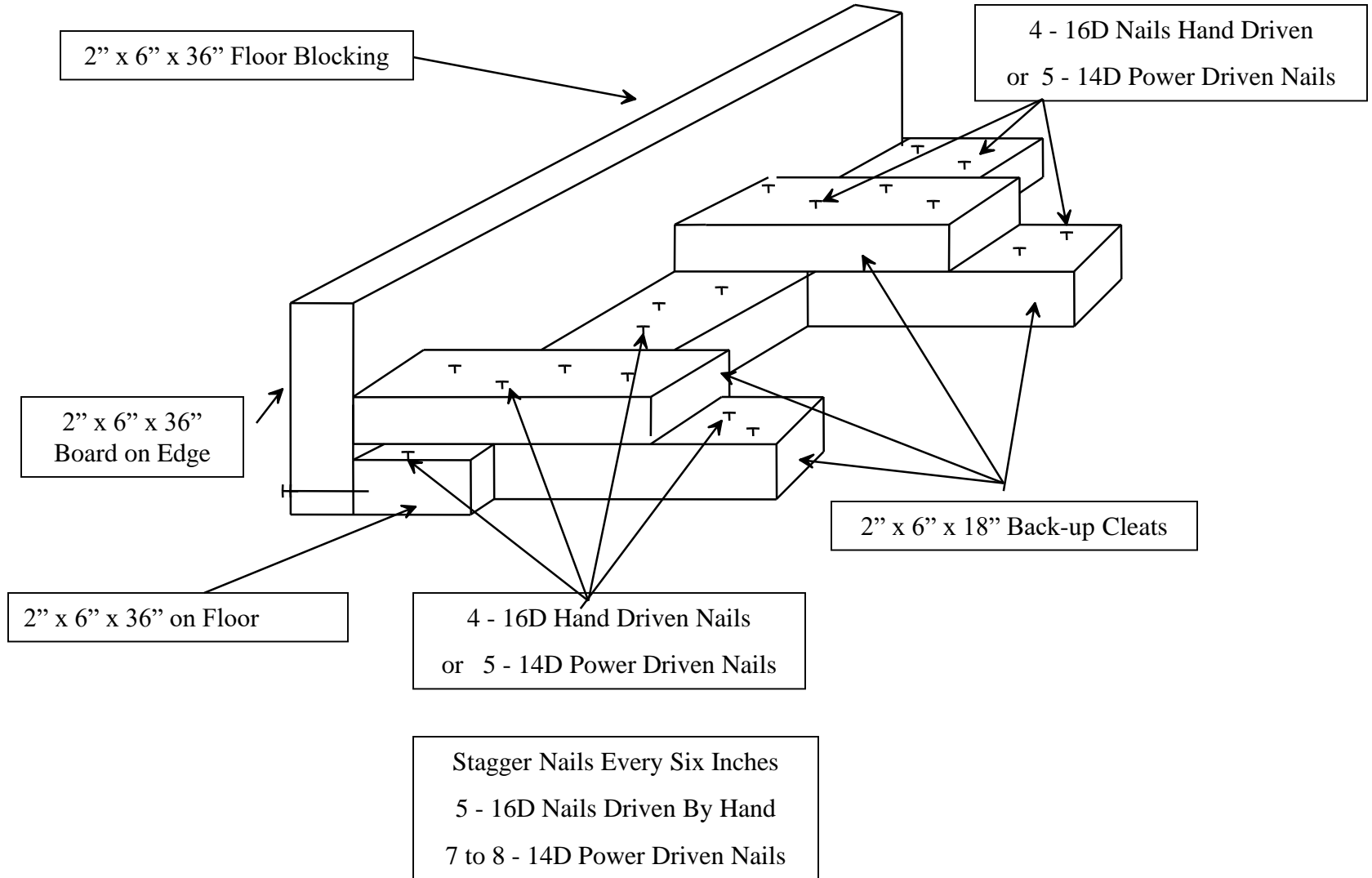
2" X 4" SIDE BLOCKING

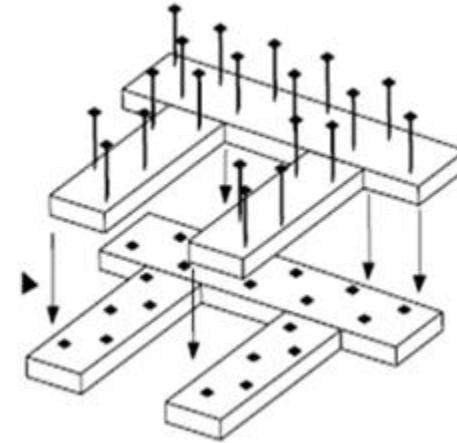
**NOTE: DEPENDENT UPON
UNIT WEIGHT, BACK-UP
CLEAT (BOTH SIDES OF LOAD)
MAY BE REQUIRED**

FLOOR BLOCKING SHOULD BE SECURELY NAILED TO THE TRAILER FLOOR AND MUST PENETRATE THE TRAILER FLOOR TO A DEPTH OF 1" OR MORE. THE NAILS SHOULD BE APPLIED IN A STAGGERED PATTERN, 4 - 6" APART (SEE BELOW).



"L"-FLOOR BLOCKING



LAMINATED FLOOR BLOCKING**SELECTING LUMBER FOR PROPER STRONG EFFECTIVE BLOCKING**

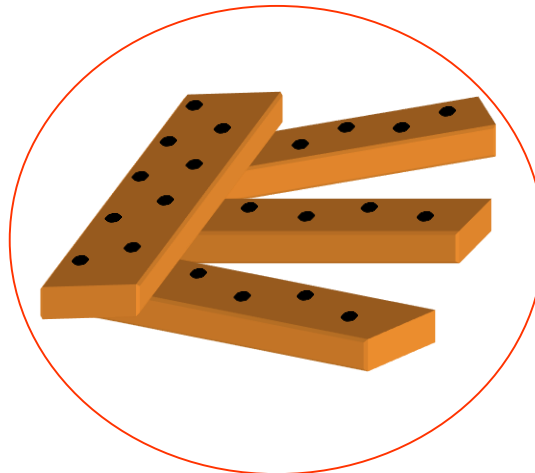
- USE PROPERLY SEASONED LUMBER, DO NOT USE GREEN LUMBER AS IT DOES NOT HAVE STRENGTH OF DRY LUMBER.
- SELECT SOUND LUMBER FREE FROM CROSSGRAIN OR DRY ROT, DO NOT USE LUMBER WITH KNOTS, KNOTHOLES AND CHECKS OR SPLITS WHICH AFFECT ITS STRENGTH OR INTERFERE WITH PROPER NAILING.
- WHEN SELECTING THE SIZE OF LUMBER FOR BLOCKING & BRACING, GIVE CONSIDERATION OF THE WEIGHT, SIZE & NATURE OF THE COMMODITY TO BE SECURED.
- TO FACILITATE DRIVING, PREVENT SPLITTING & INCREASE HOLDING POWER OF THE NAIL, PRE-DRILL HOLES SLIGHTLY SMALLER THAN THE DIAMETER OF THE SHANK OF THE NAIL.
- NAILS SIZE SHOULD BE 16D AND MAY BE DRIVEN BY HAND OR NAIL GUN STAGGERED 4" TO 6" AS DEPICTED IN ABOVE DIAGRAM. IF POWER DRIVEN USE EXTRA NAILS.

“E” - BRACING**METHOD FOR SECURING ROLLED PAPER WITH 2” X 6” WOODEN “E” BRACES**

The “E” brace securement method is for rolls of paper loaded on end in a trailer or container moving in intermodal service.

The “E” braces are constructed from four pieces of 2” x 6” x 24” lumber that is free of knots, splits, or other defects. The blocking is assembled as shown in the sketch below. The cross brace is placed on top of the three backup cleats and nailed in place with five 16D or larger nails at each backup cleat.

Each backup cleat is nailed to the floor with five 16d or larger nails evenly spaced along each backup cleat in an off set pattern as shown in the sketch below.



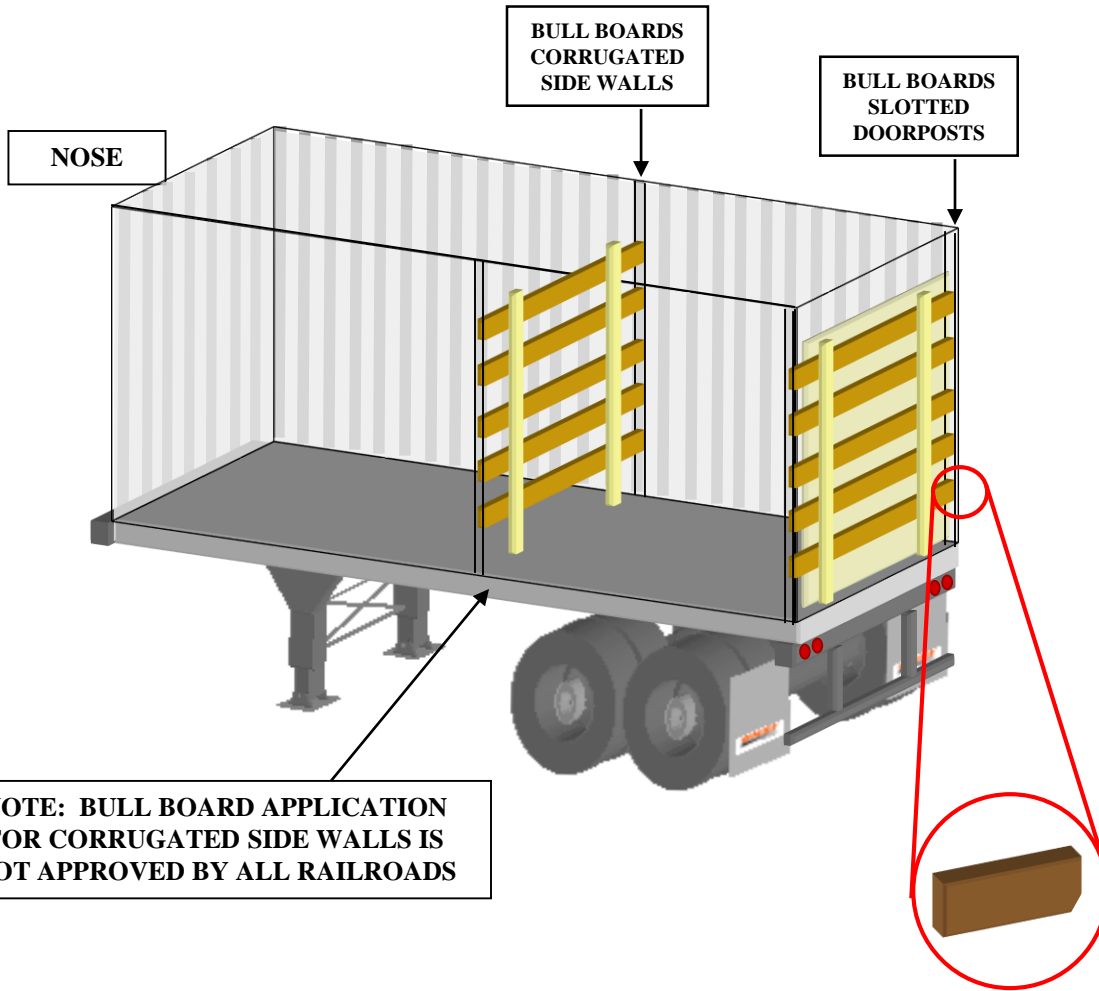
Use of Slotted Door Posts

Bull boards may be inserted into slotted door posts at rear of trailer/container to restrain low density material. (See the loading diagram on the next page.) Use minimum 2" x 4" lumber (preferably hardwood), free of knots or other strength impairing defects, of suitable length to fit snugly between doorposts. Use a sufficient number of bull boards to prevent the cargo from contacting rear doors. (See chart below) When necessary, use a wooden gate and fiberboard or plywood buffer material to fill remaining void space and evenly distribute lading forces.

<u>Restraint Device</u>	<u>Capacity</u>
2" x 4" Bull Board	5,600 lbs
2"x 6" Bull board	8,000 lbs
2" x 4" 'T' Brace	7,000 lbs

Figures developed through testing of Bull Boards and "T" Braces constructed of Yellow Pine.

BULL BOARDS

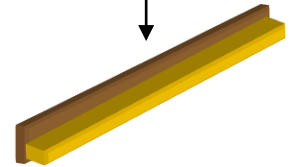


NOTE: BULL BOARD APPLICATION FOR CORRUGATED SIDE WALLS IS NOT APPROVED BY ALL RAILROADS

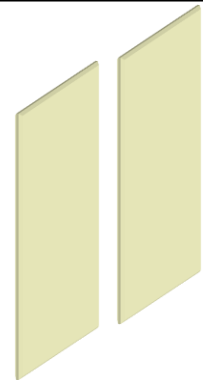
MITER CORNERS TO SIMPLIFY DROPPING BULL BOARDS IN PLACE

LOAD RESTRAINING CAPACITY	
RESTRAINT TYPE	CAPACITY
2" X 4" BULL BOARD	5,600 LBS
2" X 6" BULL BOARD	8,000 LBS
2" X 4" "T" BRACE	7,000 LBS

"T" BRACE METHOD OF REINFORCING BULL BOARD. SHOWN BACKWARDS FOR CLARITY.



PLYWOOD BUFFER MATERIAL PLACED BETWEEN LADING AND BULL BOARDS HELPS EVENLY DISTRIBUTE LADING FORCES.



SECTION V



Security Seals

Security Seals

The Shipper is responsible to protect the safety and integrity of the cargo, including, but not limited to, the application of security-type seals to the shipment for prevention of unauthorized access to the cargo. Security seals must be placed on all doors, hatches, covers, and openings used to load and/or unload cargo. Presence of a broken seal or missing seal alone does not deem the cargo to be contaminated or adulterated. The Shipper is responsible for providing documented evidence that each shipment is properly protected with security seals when tendered to BNSF.

BNSF recommends the use of a barrier type of security seal (see examples below) composed of braided steel strands [high tensile strength (non-preformed) steel cable totaling a minimum of one-eighth (1/8") inch (minimum ASTM Grade D standard)] in diameter or equivalent bolt seal, which is manufactured of material such as steel or cable with the intent to delay intrusion and is generally removed with a quality bolt or cable cutter.

Contact Resource Protection for any barrier seal questions at 1-800-832-5452.



SECTION VI



Dunnage and Unitizing Materials

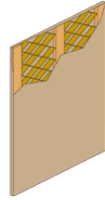
DUNNAGE MATERIALS



Honeycomb



Honeycomb Panels



Reinforced Bulk Panel



Plywood



Corrugated Risers



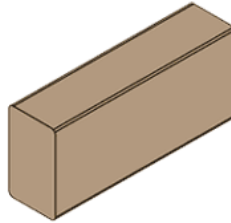
Contour Pad



Saddle Pak



Filler



Sto-Pak Airbag



Polyethylene
Airbag



Kraft Paper
Airbag



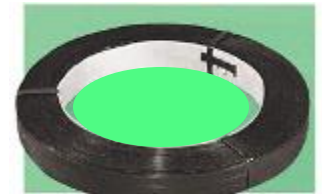
Rubber Matting



Ty-Gard™
&
Tools



Caristrap /Poly
Strapping

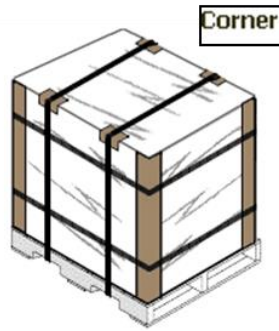


1-1/4" x .031 Steel
Banding

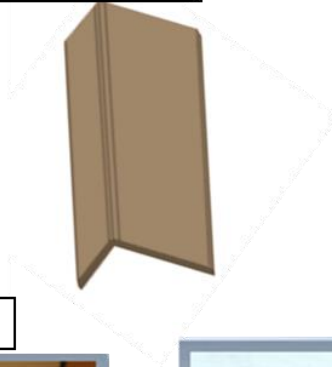
UNITIZATION METHODS



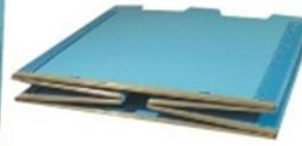
Stretch Film



Corner & Edge Protectors



Corrugated cardboard cap and sleeve cases



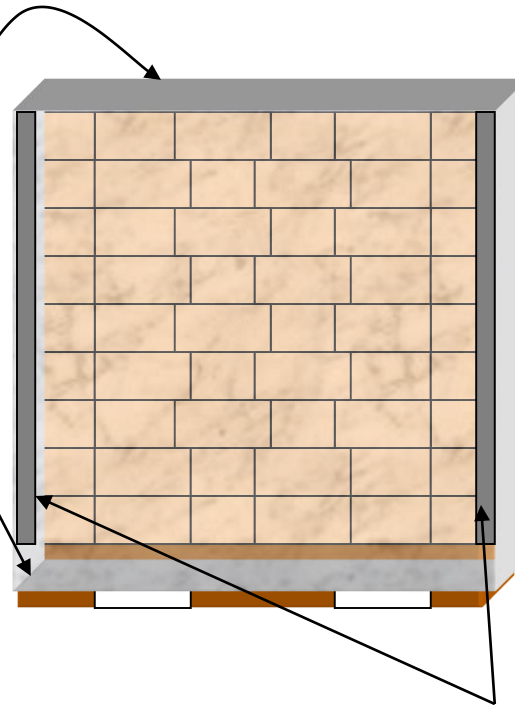
Spot Glue



STRETCH-WRAPPING

STRETCH-WRAP FOUR FULL WRAPS PER PALLET RECOMMENDED WITH THREE MINIMUM

2" OVERLAP TOP AND BOTTOM
ENCOMPASSING PALLET AND
OVER TOP OF PRODUCT



100 GAUGE, 30" WIDE

PRE-TENSIONED 150% FOR 4 WRAPS
TOP AND BOTTOM LAYER SET FOR COUNT
ROLL SPEED TO ALLOW FOR 15" OVERLAP

OPTIONAL: EDGE PROTECTION

LARS PRODUCT VENDOR LIST

This list is provided as a service to rail customers and member carriers by The Association of American Railroads. The Association of American Railroads and BNSF do not endorse or guarantee the use or reliability of the products produced or distributed by the vendors listed herein.

Allegheny Industrial Associates—An ITW Company

311 Plus Park Blvd., Suite #110
Nashville, Tennessee 37217
(800) 444-6337
(615) 399-9987
Fax: (615) 399-9982
Products:
Beverage Bulkheads
Contour Polyfoam Pads
D.I.D. Bags
Polyester Cord Strap
Rebonded Rubber Mats
Risers
Separators
Void Fillers

Amorim Industrial Solutions

26112 110th Street
Trevor, WI 53179
(800) 558-3206
Fax: (262) 862-2500
Products:
Rebonded Rubber Mats

BJK Industries, Inc.

P.O. Box 2949
Fort Smith, AR 72913
(501) 646-9300
Products:
Trailer Liners

Acme Packaging Systems/ITW

13500 S. Perry Avenue
Riverdale, IL 60627-1182
(708) 849-2500
Fax: (708) 849-4945
Products:
Plastic Strap
Steel Strap

Ancra International

4880 West Rosecrans Avenue
Hawthorne, California 90250
(310) 973-5000
Products:
Beam End Sockets
Cargo Restraining Devices
Corner Protectors
Custom Design Products
Shoring Beams
Strap Anchors
Strap Assemblies
Winches

Boomerang Packaging, Inc.

15344 Vantage Parkway E.
Houston, TX 77032
(281) 590-5163
(800) 214-2803
Fax: (281) 590-9755
Products:
Polyester Cord Strap

Caristrap International, Inc.

1760 Fortin Blvd.
Laval, Quebec Canada H7S 1N8
(450) 667-4700
(800) 361-9466
Fax: (450) 663-1520
Products:
Cargo Restraining Devices
Custom Design Products
Industrial Tapes
Non-wovens
Plastic Strap
Polyester Cord Strap
Strap Anchors

Centerload Shipping Technologies/ITW Shippers

3165 Diablo Avenue
Hayward, CA 94545
(800) 304-0031
Products:
D.I.D. Bags

Cordstrap USA

1101 South Sylvania
Sturtevant, WI 53177
(262) 898-6670
Fax: (262) 898-6677
Products:
Polyester Cord Strap

Circle Inc.

Specialized Paper Converting
911 Milwaukee Avenue
Burlington, WI 53105
(262) 539-4400
Fax: (262) 539-4409
Products:
Bulkheads
Contour Buffer Pads
Corner Protectors
Custom Designed Products
D.I.D. Bags
Risers Rubber Mats
Void Fillers

Corrugated Systems, Inc.

14700 Harvard
Dolton, Illinois 60419
(708) 849-0667
Products:
Bulkheads
D.I.D. Bags
Risers
Separators
Void Fillers

Cougar Packaging Designers, Inc.

800 Regency Drive
Glendale Heights, Illinois 60139
(630) 539-7361
Fax: (630) 539-7398
Products:
Cushion Contour Polyfoam Pads

The Damage Prevention Company

4120 Brighton Blvd.
Unit A-23
Denver, Colorado 80216
(303) 295-3003
Products:
Bulkheads
Coil/Roll Side & Edge Protectors
Contour Buffer Pads
Corner Protectors
Custom Design Products
D.I.D. Bags
Risers
Separators
Thermal Barriers
Void Fillers

Dunnage Systems, Inc.

P.O. Box 656
Sheridan, Arkansas 72510
(800) 288-4830
(870) 942-4830
Fax: (888) 942-4710
Products:
Air Compressors
Bulk Containers
Bulkheads
Contour Buffer Pads
D.I.D. Bags
Risers
Separators
Slip Sheets
Void Fillers

E. J. Brooks

World Headquarters
8 Microlab Road
Livingston, NJ 07039
(800) 458-SEAL
(973) 597-2900
(973) 597-2919
Products:
Security Seals
Locking Devices

Fleet Products & Equipment, L.L.C

1920 Swift Avenue, Suite 202
N. Kansas City, Missouri 64116
(816) 221-1664
Products:
Bulk Containers
Cargo Restraint Devices
D.I.D. Bags
Separators
Slip Sheets
Stretch Wrap

Gerrard Ovalstrapping

Forest Products Division
120-55th Street N.E.
Fort Payne, AL 35967-8140
(256) 845-1914
Fax: (256) 845-1493
Products:
Polyester Cord Strap

Greif, Inc.—now ITW Down River

701 West Scott Avenue
Woodland, WA 68674
(360) 225-9995
Fax: (866) 675-2391

Products:

Buffer Material / Contour Buffer Pads
Bulkheads
Car Liner Sheets
Corner Protectors
D.I.D. Bags
Drum Separators
Honeycomb Panels
Risers / Separator Pads
Slip Sheets / Tier Sheets

Holland Company

1000 Holland Dr
Crete, IL 60417
(708) 672-2300

Products:

Car components
Cargo Sleds

Industrial Packaging Supplies

10 Jack Casey Court
Fountain Inn, SC 29644
(864) 862-1500
(864) 862-1005

Products:

D.I.D. Bags
Plastic Strap
Steel Strap

Interlake Packaging Corp.

1515 W. Mohawk Drive
Tomahawk, WI 54487
(715) 453-2223
Fax: (715) 453-7972

Products:

Void Fillers
Corrugated

International Dunnage LLC

3216 Center Street
Thunderbolt, GA 31404 USA
(912) 355-8884
Fax: (912) 355-7234

Products:

D.I.D. Bags
Straps and Buckles
Inflator Tools

Instrumented Sensor Technology

4704 Moore St.
Okemos, MI 48864 USA
(517) 349-8487
Fax: (517) 349-8469

Products:

Shock and Vibration Recorders
Accelerometers
Temperature and Humidity Recorders Data
Loggers
Data Acquisition

IRECO LLC

805 Golf Lane
Bensenville, IL 60106
(630) 741-0155
Fax: (630) 595-0646

Products:

Lading Anchors

ITW CargoSafe

1203 N. Main Street
Mt Pleasant, TN 38474
(931) 380-9428

Products:

Beam End Sockets
Cargo Restraint Devices
Corner Protectors
Load Bars
Shoring Beams
Strap Anchors
Strap Assemblies
Track
Winches

Ride Rite/ITW Shippers

300 South Edgar
Fordyce, AR 71742
(800) 468-1230

Products:

D.I.D. Bags

Kinedyne Corp.

3701 Greenway Circle
Lawrence, Kansas 66046-5442
(785) 841-4000
Fax: (785) 841-3668

Products:

Beam End Sockets
Cargo Restraint Devices
Corner Protectors
Custom Design Products
Shoring Beams
Strap Anchors
Strap Assemblies
Winches

Koneta Rubber Company

Matting Division
1400 Lunar Drive
Wapakoneta, Ohio 43895
(419) 739-4200
Products:
Rubber Mats

Lansmont Corporation

Ryan Ranch Research Park
17 Mandeville Court
Monterey, CA 93940 USA
(831) 655-6600
Products:
Data Loggers
Temperature Recorders
Humidity Recorders
Vibration Measurement Tools
Test Instruments

Lat-Lon

2300 South Jason Street
Denver, CO 80223
(877) 300-6566
(303) 937-7406
Fax: (303) 531-5754
Products:
Data Recorders

Logistick

19880 State Line Road
South Bend, IN 46637-1545
(800) 758-5840
(574) 271-2565
Fax: (574) -271-2574
Products:
Blocking and Bracing Devices
Strapping
D.I.D. Bags
Void Fillers
Security Seals
Corner Protectors

Lock 'n' Pop

20508 56th Avenue, West
Lynwood, WA 98036
(800) 225-3009
Products:
Lock 'n' Pop

Lodge Lumber Company Inc.

5001 Oates Road
Houston, TX 77213
(713) 672-6679
Fax: (713) 672-5135
Products:
Separators

Maillis Strapping Systems

404 Wall Street
Fountain Inn, SC 29644-2035
(877) 962-4648
Products:
Polyester Strapping
Plastic Strapping
Strapping Tools

Menasha Packaging Company

1645 Bergstrom Road
Nenah, WI 54957
(920) 751-1000
Products:
Corrugated Boxes
Corrugated Fanfold
Bulk Containers

Moldwood Corp.

104 Mallard Circle
York, AL 36925
(205) 392-5257
Products:
Core Plugs

National Rubber Technologies Corp.

1505 Hickory Hill Lane
Brookfield, WI 53045
(800) 785-3986
(262) 785-7536
Fax: (262) 785-7537
Products:
Custom Design Products
Masticated Rubber
Rubber Mats

Packaging Un-Limited Inc.

2215 Augustine Street
Covington, KY 41014
(859) 431-6194

Fax: (859) 431-0808

Products:

Bulkheads
Corrugated Pallets
Custom Wood and Paper Products
Edge Protectors
Poly Foam pads
Risers
Roll Headers
Separator Pads
Void Fillers

Pasadena Slid and Pallet Co.

5202 Red Bluff Road
Pasadena, TX 77508
(281-991-0190

Fax: 281-991-0905

Products:

Eucalyptus Hardboard
Skids and Pallets
Corrugated Pallets
Palletizing Materials

Pensacola Skid & Pallet

351 Becks Lake Road
Cantonment, Florida 32533
(850) 968-1504

Fax: (850) 968-9393

Products:

Pre-assembled Bulkheads

PlasTech Inc.

70 S. Eaton Ct.
Lakewood, Colorado 80226

(800) 919-6919

(303) 202-0852

Fax: (303) 202-0454

Products:

Separators
Slip Sheets
D.I.D. Bags
Void Fillers

PlyVeneer Products

800 48th Street
Springfield, OR 97478

(866) 447-0771

(541) 747-0771

Fax: (541) 747-0775

Products:

Ply Veneer Panels

Pregis Corp.

1650 Lake Cook Road, Ste. 400
Deerfield, IL 60015

(847) 597-2200

(800) 834-9441

Products:

Void Fillers
Die Cut Honeycomb
Honeycomb Pallets

Prom Industries

13812 N.E. Clark Road
Vancouver, WA 98685

(360) 573-3611

Fax: (360) 573-8110

RB Rubber Products

904 E. 10th Avenue
McMinnville, OR 97128

(503) 472-4691 / (800) 525-5530

Fax: (503) 434-4455 / (800) 888-1183

RC Packaging Systems, Inc.

4935 Technical Drive
Milford, MI 48381

(248) 684-6363

Fax: (248) 685-3521

Products:

Polyester Cord Strap

RFTrax—Now IONX

515 S. Franklin Street
West Chester, PA 19382

(484) 653-2600

Products:

Rail Asset Tracking
Data Acquisition Devices

Shockwatch Corp.

W. Mockingbird Lane
Dallas, TX 75247

(800) 527-9497

Fax: (214) 638-4512

Products:

Data Acquisition Monitors

Safety Corporation of America -

(Formerly: Vetter Systems, Inc.)

1005 International Drive

Oakdale, PA 15071

(412) 695-3100

Fax: (412) 695-3232

Products:

Rubber Lifting Bags

Samuel Strapping Systems

1455 James Parkway

Heath, OH 43056

(800) 222-1855

Fax: (614)863-7330

Products:

Steel Strap

Plastic Strap

ITW Shippers

1203 N. Main Street

P.O. Box 69

Mt. Pleasant, Tennessee 38474

(615) 379-7731

(800) 933-7731

Fax: (615) 379-7735

Products:

Air Compressors

Angleboard

Bulk Containers

Coil/Roll Edge Protectors

Contour Buffer Pads

D.I.D. Bags

Load Bars

Roll Risers

Rubber Mats

Separators

Slip Sheets

Void Fillers

Ship Tech International, Inc.

385 Montana Drive

P.O. Box 492

Seely Lake, MT 59868

(800) 771-2196

(406) 677-2907

Fax: (406) 677-5021

Products:

Bulkheads

Contour Buffer Pads

D.I.D. Bags

Poyester Cord Strapping

Rebonded Rubber Mats

Risers

Void Fillers

Signode/ITW

800 Corporate Woods Parkway

Vernon Hills, IL 60061

(800) 323-2464

Fax: (847) 913-9078

Products:

Load Cushioners

Plastic Strap

Polyester Cord Strapping

Steel Strapping

Strap Anchors

Southern Strapping Systems

1900 Parish Drive

Rome, GA 30161

(800) 524-7513

Fax: (706) 291-0229

Products:

Polyester Strapping

Southern Bracing Systems, Inc.

P.O. Box 761

Rome, GA 30161

(706) 291-4206

Fax: (706) 291-0229

Products:

Bulkheads

Cargo Restraining Devices

Contour Buffer Pads

Corner Protectors

Custom Design Products

D.I.D. Bags

Polyester Cord Strap

Risers

Rubber Mats

Separators

Laminated Bulkhead (Ty-gard□)

Void Fillers

Sunrise Arkansas, Inc.

400 Airline Drive

Benton, Arkansas 72015

(800) 264-5411

Fax: (501) 778-6335

Products:

Bulkheads

D.I.D. Bags

Risers

Separators

Void Fillers

Sunrise Mfg., Inc

2665 Mercantile Drive
Rancho Cordova, CA 95742

(800) 748-6529

Fax: (916) 635-9730

Products:

Buf-Bags

Bulkheads

D.I.D. Bags

Laminated Bulkheads (Ty-gard□)

Polyester Strap

Rubber Matting

Separators

Slip Sheets

V-Boards

Void Fillers

Sunrise Washington, Inc.

5900-A N.E. 88th Street #119

Vancouver, WA 98665

(360) 574-3512

(888) 485-4085

FAX: (360) 574-7695

Products:

Buf-Bags

Bulkheads

D.I.D. Bags

Corner Protectors

Void Fillers

Laminated Bulkheads Ty-Gard 2000)

Corrugated Pallets

Rubber Matting

Polyester Strap

Slip Sheets

Stretch Film

Roll Risers

Security Seals

SPC Solutions

500 South 59th Avenue West

Duluth, MN 55807

(800) 705-5279

(218) 624-8945

Fax: (218) 624-8949

Products:

Angle board

Beam and Sockets

Beverage Bulkheads

Bulk Containers

Bulkheads

Car Liner Sheets

Cargo Restraining Devices

Core Plugs

Corner Posts

Corner Protectors

Contour Buffer Pads

Cushion Contour Poly Foam Pads

Custom Design Products

DID Bags

Laminated Bulkheads

Load Bars

Metal Blocking Devices

Rebonded Rubber Pads

Risers

Rubber Mats

Separators

Shore and Beams

Slip Sheets—Paper and Plastic

Strap Anchors

Strap Assemblies

Stretch Wrap Equipment and Film

Thermo Barriers

Top Caps

Void Fillers

Tapex American Corporation

2626 20th Street

Port Huron, MI 48061-0233

(810) 987-4722

Fax:(810) 987-4728

Products:

Polyester Cord Strap

TydenBrammall

409 Hoosier Drive

Angola, IN 46703

(800) 348-4777

Products:

Security Seals

Ultimate Systems Ltd.

1430 N. Main St

Delphos, OH 45833

(419) 692-3005

Fax: (419) 692-1401

Products:

Rubber Mats

UNSA America

5921 Thurston Ave.

Virginia Beach, VA 23455

(757) -552-0507

Fax: (757) 490-1548

Products:

Bulk bags

D.I.D. Bags

Walnut Industries Inc.

1356 Adams Road

Bensalem, Pennsylvania 19020

(800) 523-6536

(215) 638-7847 (in PA)

Fax: (215) 638-4939

Products:

Laminated Bulkheads (Ty-gard□)

SECTION VII



BNSF Approved Methods

BNSF RAILWAY – LOAD AND RIDE SOLUTIONS (LARS) APPROVED LOADING METHODS



When working with our customers, BNSF Load and Ride Solutions will occasionally develop loading methods that do not meet all of the requirements of AAR published loading and securement rules. Those loading methods that have performed successfully when moving on the BNSF System are included in this publication.

Important! Use of BNSF Railway loading and securement methods are restricted to shipments moving on BNSF and final approval must be obtained from a Load and Ride Solutions Manager *prior* to shipping. These loading methods cover shipments of non-hazardous material commodities, unless otherwise approved by a Load And Ride Solutions Manager. Finally, because BNSF loading methods are not necessarily authorized with other rail carriers, *it is the shipper's responsibility to obtain authorization from all carriers* in the routing.

Contact Load And Ride Solutions: If you do not see a loading diagram specific to the commodity that you are shipping, or you are attempting to obtain approval for one of the loading methods outlined in this publication, please contact your local LARS Manager for assistance.

<http://www.bnsf.com/customers/support-services/loading-and-shipment-safety/>

REAR DOOR SECUREMENT METHOD



REAR DOOR SECUREMENT METHOD

As stated previously, intermodal equipment doors are not designed to restrain cargo movement. BNSF has found that intermodal equipment doors generally cannot be expected to fully restrain the load. If the cargo is rigid or very dense in nature (e.g., boxes of nuts and bolts, copier paper, lumber, steel products, machinery, etc.) or if the cargo is cylindrical in shape (e.g., rolled paper, rolled plastics, drums, etc.), additional blocking and bracing is required. The intermodal equipment doors are neither designed nor intended to restrain commodities with these characteristics. Such products must be loaded and secured in conformance with the rules and illustrations in this publication. However, intermodal equipment doors meeting Association of American Railroads door design specifications can be utilized for load securement under the following conditions:

- 1.) Cargo is multi-unit, light-weight and high cube; such as boxes of food stuffs, tissue or soft paper products, furniture, appliances, etc.**
- 2.) Cargo must be loaded tightly, both longitudinally and laterally in the equipment, allowing no room for movement. Any void that exists should be filled with recommended dunnage material.**
- 3.) The load must come to the equipment doors with an even load face, covering a minimum of 60% of the door area. In straight floor equipment, minimum height of load would be 5' 4" and in a drop frame trailer, minimum height of load would be six feet. In both cases, the full width of the equipment is assumed to be filled.**
- 4.) The doors must fit squarely, the hinges tight, and the locking bars must be in good condition and function properly.**

CAUTION: Private equipment may not be designed according to the AAR specifications, and therefore, unable to withstand the rigors of the rail environment. It is recommended that blocking and bracing be utilized for load securement.

AAR CIRCULAR 43-E, "RULE 5-A"

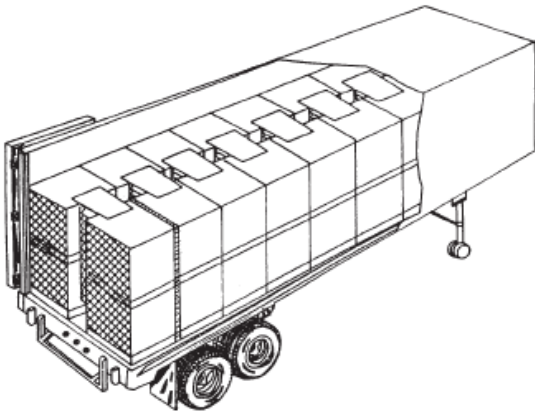
Trailer/container doors may **NOT** be used to secure loads containing **Hazardous Materials**. Under certain conditions, As outlined in Rule-5A, Section II (Circular 43-D) below, trailer/container doors can be relied on to secure Non-hazardous Materials lading.

Rule 5A. Section II (Circular 43D)**5. Loading and Securement**

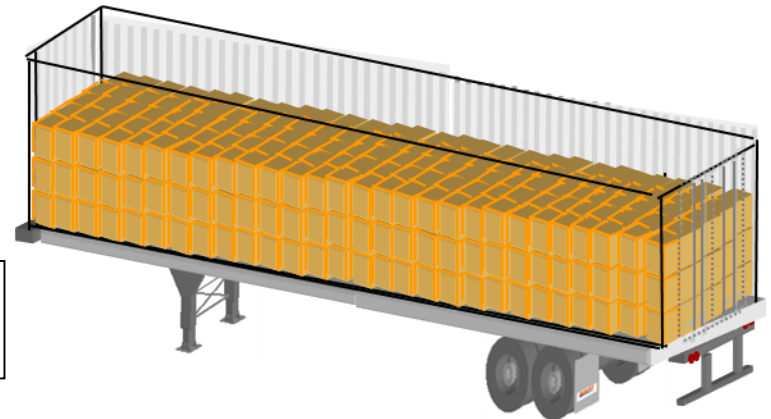
A) Secure cargo to prevent lengthwise movement. If the cargo is rigid in nature and/or very dense, such as boxes of nuts or bolts, machinery, metal beams, brick, lumber, cut paper, etc., or if the shape of the cargo is such that the area of the door Contact is minimal, such as with cylindrical objects like drums or rolled paper, blocking and bracing is necessary. Vehicle doors are neither designed nor intended to restrain commodities with these characteristics. Such products must be loaded and secured in conformance with the rules and illustrations in Circular 43-D.

The doors of the vehicle, meeting AAR M931 specifications, can be relied on to secure cargo under the following condition.

1. The load consists of multi-unit cargo such as boxes of food-stuff, tissue or soft paper products, furniture, appliances, etc., Not exceeding 40,000 lbs., covering a maximum of 60% of the door area and even distributed throughout the trailer/container.
2. Cargo must be loaded tightly lengthwise and crosswise and flush to the rear door of the trailer/container allowing no room for movement. If any void exists, fill void space with recommended dunnage.
3. The doors must fit squarely, the hinges must be tight, and locking bars must be in good condition and function properly.



Examples of Loads That
Could Conform to Rule-5A
As Stated Above



CASE GOODS (Food, Beverages and More)



For illustrative purposes, the standard size 40” x 48” pallet is described for all loading methods.

Palletized Case Goods (2 - 2 Offset Pattern with Singles) – Braced with D.I.D. Bags

Palletized case goods unitized with either shrink-wrap or stretch-wrap in accordance with the manufacturer's specifications. The D.I.D. bags must be a minimum of 48" x 96" (level 1). Two D.I.D. bags are utilized for load securement; the first is placed in the center of the load and the second at the rear of the load.

Pallets are loaded in a 2-2 offset pattern, while single units are laterally centered. The pallet's 48" dimension is loaded lateral in 100-102" width equipment and the 40" dimension is loaded lateral in 96-98" width equipment. Loaded lateral = perpendicular to equipment sidewalls. The load plan should minimize lateral void space. Except at D.I.D. bag locations (100-102" width equipment), it's permissible to load the 48" dimension longitudinal in order to "stretch out the load" and maintain proper OTR axle weights.

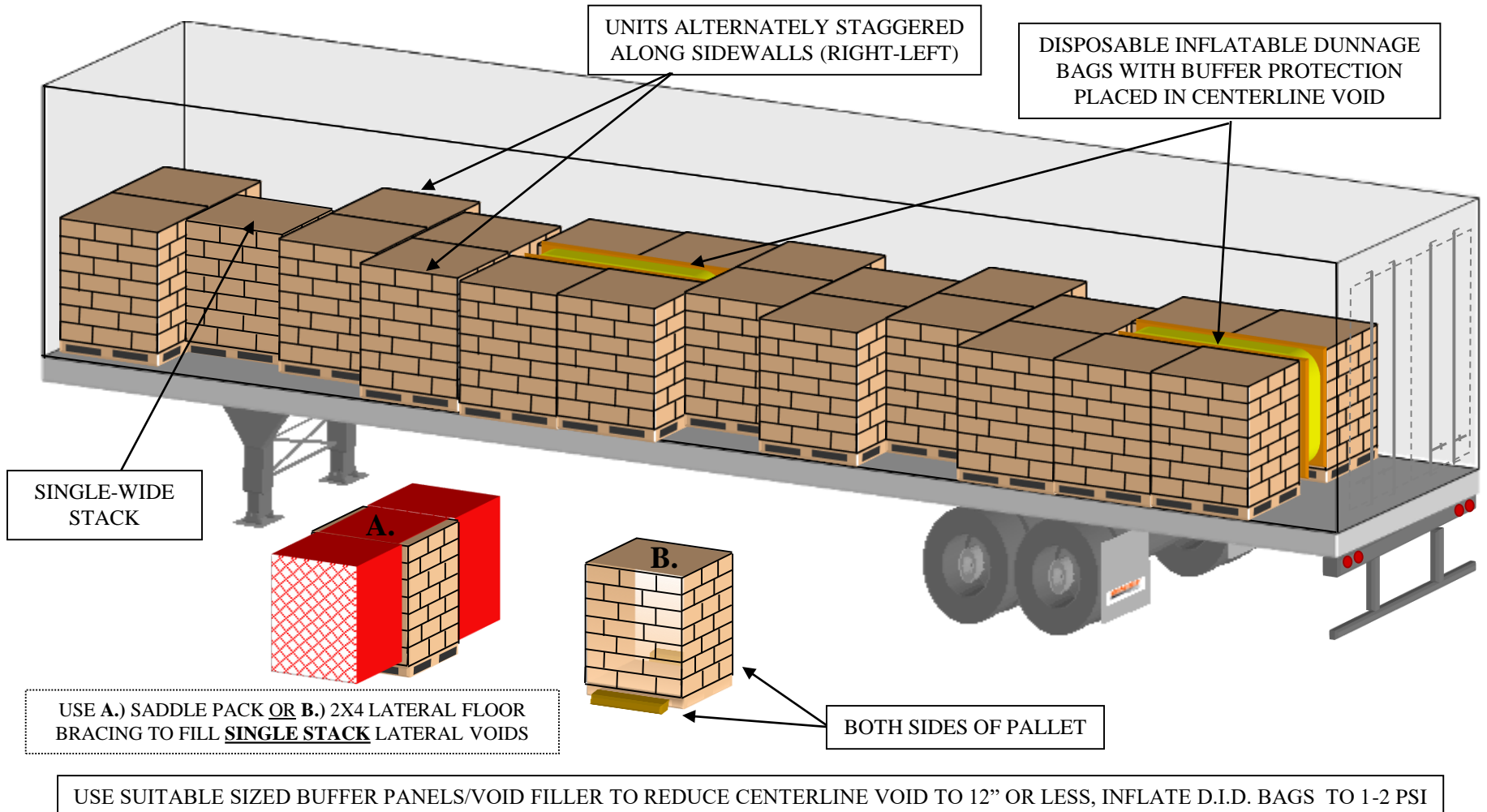
Single-wide pallets should be blocked/braced with either A.) saddle-pack fillers or B.) wood floor blocking.

When product underhang of the pallet exists, it's possible for the product to migrate or move on the pallet. Any product movement has the potential to cause product damage. Product underhang of the pallet is considered void space and should be filled with recommended dunnage material.

Disposable Inflatable Dunnage (D.I.D.) Bag – Notes

The D.I.D. bag must not be used for a void space in excess of 12" wide. When the void space exceeds 12" width, additional full size void fillers must be placed along side the D.I.D. bag. After inflation, the D.I.D. bag should be located approximately 4" above the equipment floor. The D.I.D. bag must be adequately buffered to prevent contact with sharp or rough edges that may puncture the bag. Maximum D.I.D. bag inflation of 2 PSI. Leave approximately 24" space between the rear of the load and the equipment doors.

**PALLETIZED CASED GOODS 2-2 OFFSET PATTERN WITH SINGLE STACKS
STRETCH WRAP TO SECURE TO PALLETS, INCLUDING WRAPING OVER PALLET EDGES**



Palletized Case Goods (2 - 2 Offset Pattern) – Braced with D.I.D. Bags

Palletized case goods unitized with either shrink-wrap or stretch-wrap in accordance with the manufacturer's specifications.

The D.I.D. bags must be a minimum of 48" x 96" (level 1). Two D.I.D. bags are utilized for load securement; the first is placed in the center of the load and the second at the rear of the load.

The pallets are loaded in a 2-2 offset pattern. The pallet's 48" dimension is loaded lateral in 100-102" width equipment and the 40" dimension is loaded lateral in 96-98" width equipment. Loaded lateral = perpendicular to equipment sidewalls. The load plan should minimize lateral void space. Except at D.I.D. bag locations (100-102" width equipment), it's permissible to load the 48" dimension longitudinal in order to "stretch out the load" and maintain proper OTR axle weights.

When product underhang of the pallet exists, it's possible for the product to migrate or move on the pallet. Any product movement has the potential to cause product damage. Product underhang of the pallet is considered void space and should be filled with recommended dunnage material.

Disposable Inflatable Dunnage (D.I.D.) Bag - Notes

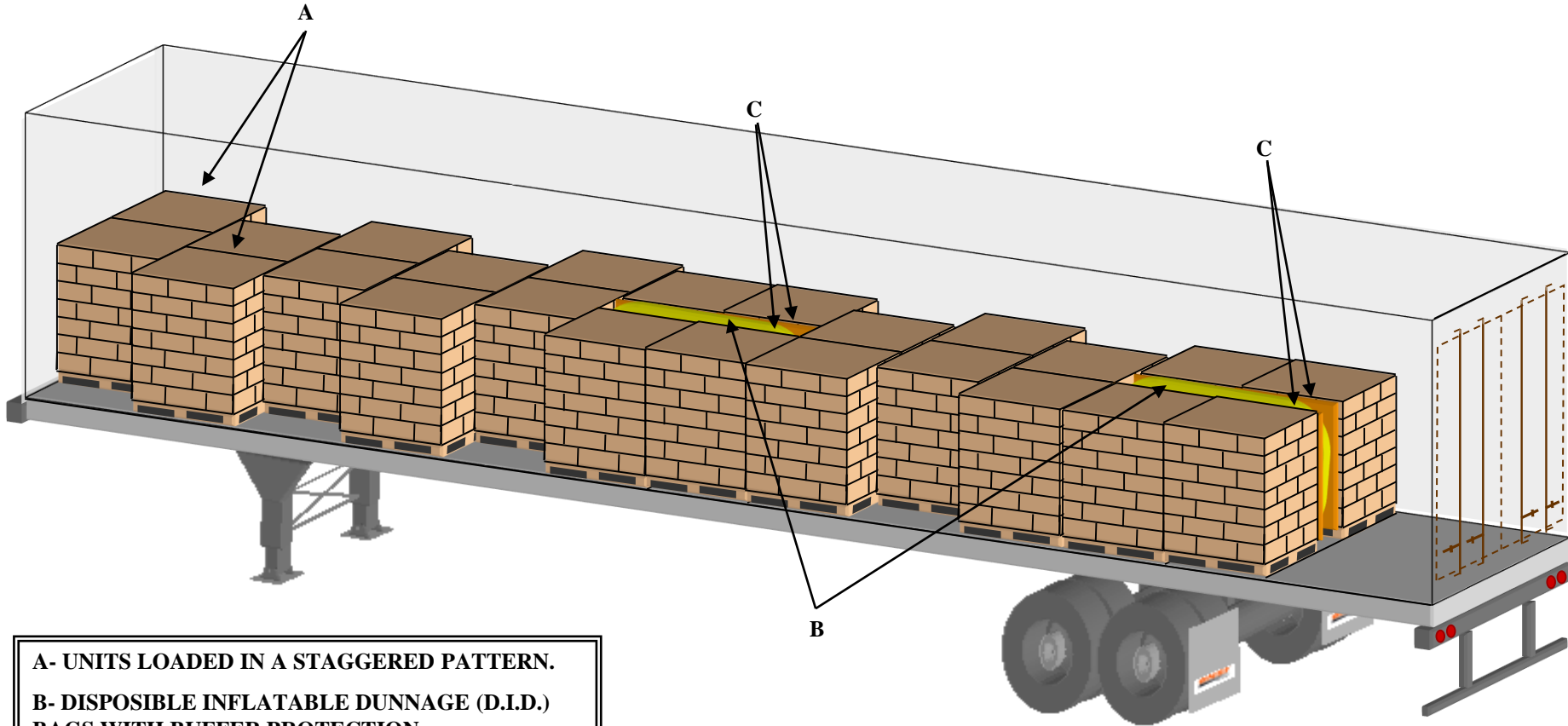
The D.I.D. bag must not be used for a void space in excess of 12" wide. When the void space exceeds 12" width, additional full size void fillers must be placed along side the D.I.D. bag.

After inflation, the D.I.D. bag should be located approximately 4" above the equipment floor. The D.I.D. bag must be adequately buffered to prevent contact with sharp or rough edges that may puncture the bag.

Maximum D.I.D. bag inflation of 2 PSI.

Leave approximately 24" space between the rear of the load and the equipment doors

**PALLETIZED CASED GOODS 2-2 OFFSET PATTERN
STRETCH WRAP TO SECURE TO PALLETS, INCLUDING WRAPING OVER PALLET EDGES**



- A- UNITS LOADED IN A STAGGERED PATTERN.**
- B- DISPOSABLE INFLATABLE DUNNAGE (D.I.D.) BAGS WITH BUFFER PROTECTION.**
- C- SUITABLE FILLER MATERIAL AS NEEDED.**
- * PRODUCT UNDERHANG OF PALLET MUST BE FILLED.**

Palletized Case Goods (2 - 2 Offset Pattern) with Partial Top Layer *Center Section Braced with D.I.D. Bags*

Palletized case goods unitized with shrink-wrap or stretch-wrap in accordance with manufacturer's specifications.

D.I.D. bags must be a minimum of 48" x 96" (level 1). Three D.I.D. bags are utilized for load securement; two bags are placed vertically at the front and rear top-layer stacks in the center of the load, and the third bag is placed horizontally at the rear of the load. The two vertical bags include both top and bottom layer palletized units.

Pallets are loaded in a 2-2 offset pattern. The pallet's 48" dimension is loaded lateral in 100-102" width equipment and the 40" dimension is loaded lateral in 96-98" width equipment. Loaded lateral = perpendicular to equipment sidewalls. The load plan should minimize lateral void space. The partial top-layer pallets should be loaded in a configuration that supports proper equipment weight distribution.

When product underhang of the pallet exists it's possible for the product to migrate or move on the pallet. Any product movement has the potential to cause product damage. Product underhang of the pallet is considered void space and should be filled with recommended dunnage material.

Disposable Inflatable Dunnage (D.I.D.) Bag - Notes

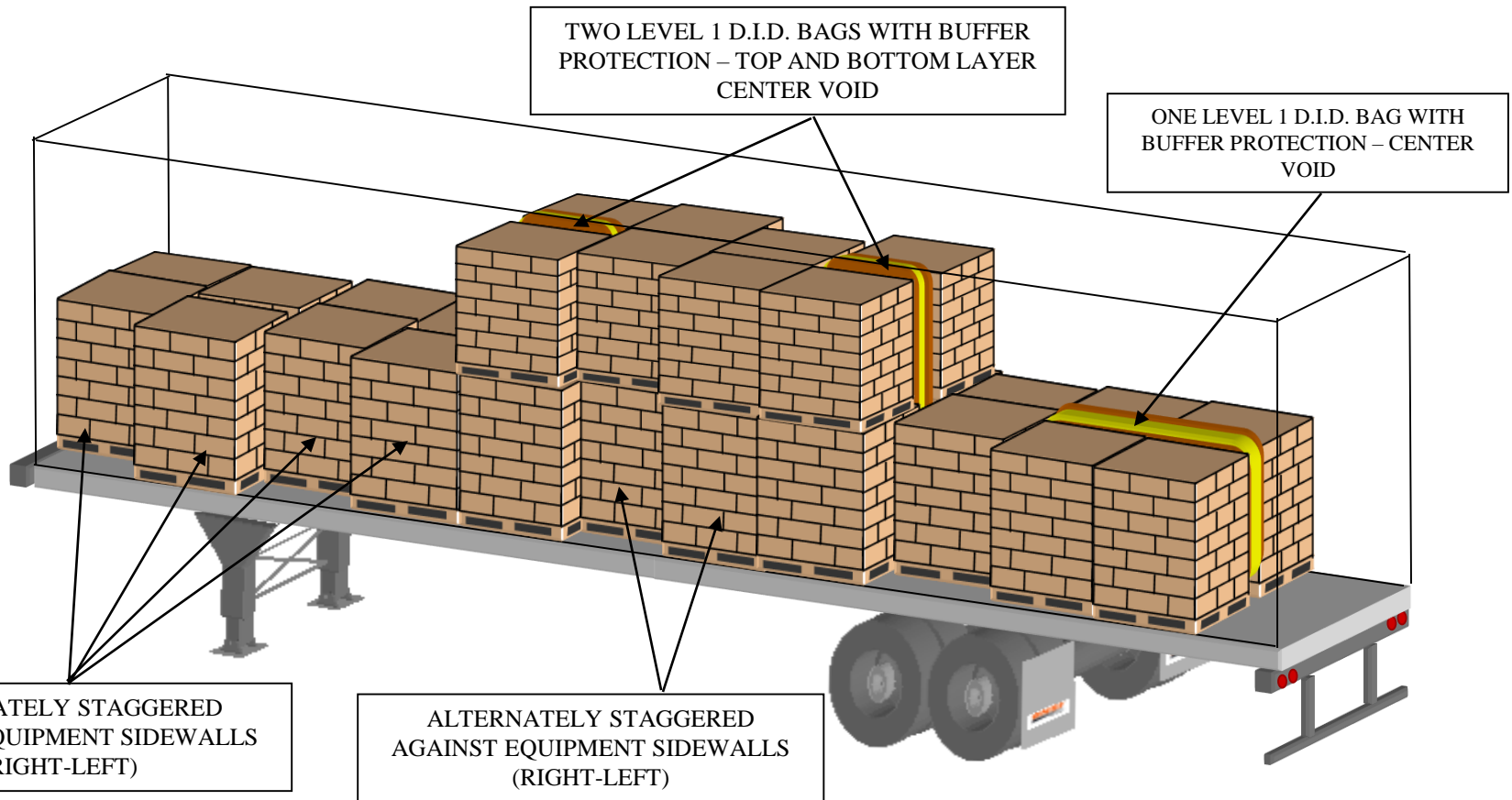
The D.I.D. bag must not be used in a void space in excess of 12". If the void space exceeds 12" width, additional full size void fillers must be placed along side the D.I.D. bag.

After inflation, the D.I.D. bag should be located approximately 4" above the equipment floor. The D.I.D. bag must be adequately buffered to prevent contact with sharp or rough edges that may puncture the bag.

Maximum D.I.D. bag inflation of 2 PSI.

Leave approximately 24" space between the rear of the load and the equipment doors.

PALLETIZED CASE GOODS (2-2 OFFSET) - PARTIAL TOP LAYER



NOTE: D.I.D. BAGS MUST NOT BE USED IN VOID SPACES IN EXCESS OF 12”, MUST NOT CONTACT FLOOR OF TRAILER OR PALLET AFTER INFLATION, MUST BE ADEQUATELY BUFFERED WHEN IN CONTACT WITH ROUGH SURFACES, AND SHOULD BE INFLATED NO MORE THAN 1-2 PSI. IF CENTERLINE VOID EXCEEDS 12” ADDITIONAL VOID FILLERS MUST BE PLACED ALONG SIDE D.I.D. BAG.

Palletized Case Goods (2 - 2 Offset Pattern) - Partial Top Layer

Nose Section Braced with D.I.D. Bags

Palletized case goods unitized with shrink-wrap or stretch-wrap in accordance with manufacturer's specifications.

D.I.D. bags must be a minimum of 48" x 96" (level 1). Three D.I.D. bags are utilized for load securement; one bag is placed horizontally at the rear of the top-layer stacks in the nose section, while the two remaining bags are placed at the center and rear of the load.

Pallets are loaded in a 2-2 offset pattern. The pallet's 48" dimension is loaded lateral in 100-102" width equipment and the 40" dimension is loaded lateral in 96-98" width equipment. Loaded lateral = perpendicular to equipment sidewalls. The load plan should minimize lateral void space. The partial top-layer pallets should be loaded in a configuration that supports proper equipment weight distribution.

When product underhang of the pallet exists it's possible for the product to migrate or move on the pallet. Any product movement has the potential to cause product damage. Product underhang of the pallet is considered void space and should be filled with recommended dunnage material.

Disposable Inflatable Dunnage (D.I.D.) Bag - Notes

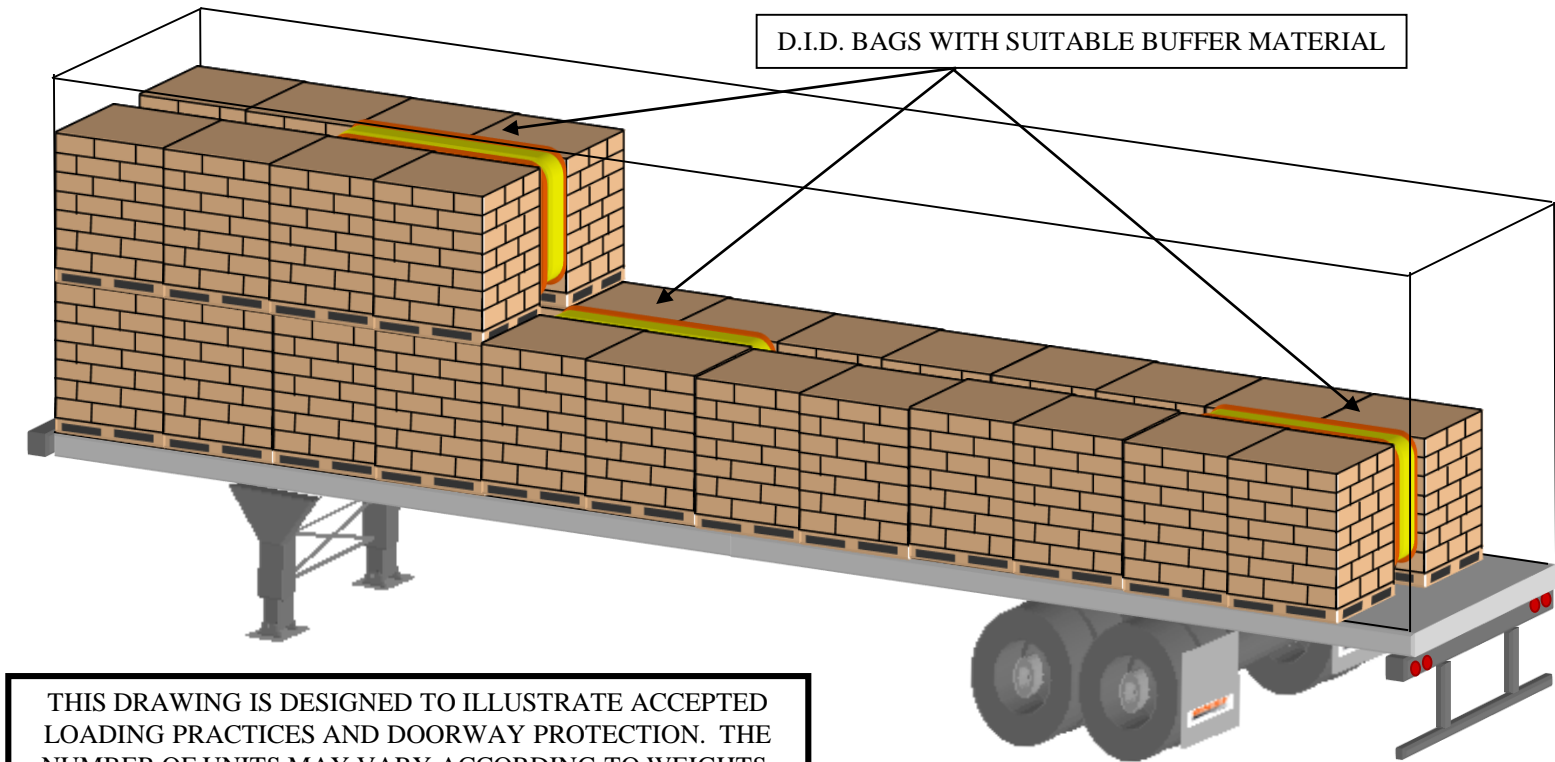
The D.I.D. bag must not be used in a void space in excess of 12". When the void space exceeds 12" width, additional full size void fillers must be placed along side the D.I.D. bag.

After inflation, the D.I.D. bag should be located approximately 4" above the equipment floor. The D.I.D. bag must be adequately buffered to prevent contact with sharp or rough edges that may puncture the bag.

Maximum D.I.D. bag inflation of 2 PSI.

Leave approximately 24" space between the rear of the load and the equipment doors.

PALLETIZED CASE GOODS (2-2 OFFSET) - PARTIAL TOP LAYER



THIS DRAWING IS DESIGNED TO ILLUSTRATE ACCEPTED LOADING PRACTICES AND DOORWAY PROTECTION. THE NUMBER OF UNITS MAY VARY ACCORDING TO WEIGHTS, CONTAINER SIZE AND CAPACITY. NOT TO SCALE.

NOTE: D.I.D. BAGS MUST NOT BE USED IN VOID SPACES IN EXCESS OF 12", MUST NOT CONTACT FLOOR OF TRAILER OR PALLET AFTER INFLATION, MUST BE ADEQUATELY BUFFERED WHEN IN CONTACT WITH ROUGH SURFACES, AND SHOULD BE INFLATED NO MORE THAN 1-2 PSI. IF CENTERLINE VOID EXCEEDS 12" ADDITIONAL VOID FILLERS MUST BE PLACED ALONG SIDE D.I.D. BAG.

Palletized Case Goods – Split Load Pattern

53' Containers with Ridged Single Plate or Multi-wall Type Construction

Palletized case goods unitized with shrink-wrap or stretch-wrap in accordance with manufacturer's specifications.

D.I.D. bags must be a minimum of 48" x 96" (level 1). Four D.I.D. bags are utilized for load securement; two bags are placed at the front and rear of the nose section of load, and the remaining two bags are placed at front and rear of the rear section of load.

The pallet's 48" dimension is loaded lateral in 100-102" width equipment and the 40" dimension is loaded lateral in 96-98" width equipment. Loaded lateral = perpendicular to equipment sidewalls. The load plan should minimize lateral void space. The distance between nose section load and rear section load should support proper equipment weight distribution and OTR axle weights.

When product underhang of the pallet exists it's possible for the product to migrate or move on the pallet. Any product movement has the potential to cause product damage. Product underhang of the pallet is considered void space and should be filled with recommended dunnage material.

Disposable Inflatable Dunnage (D.I.D.) Bag - Notes

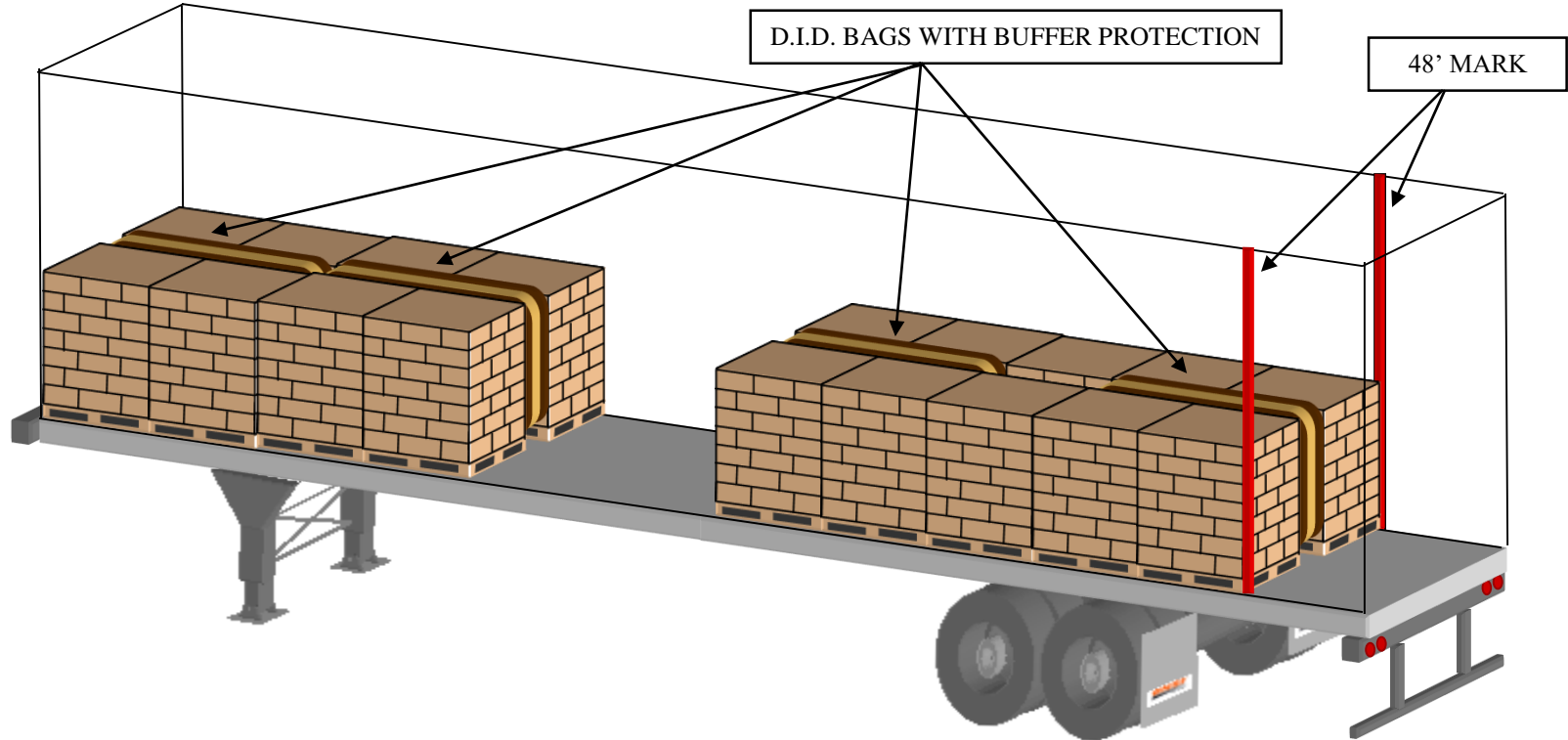
The D.I.D. bag must not be used in a void space in excess of 12". If the void space exceeds 12" width, additional full size void fillers must be placed along side the D.I.D. bag.

After inflation, the D.I.D. bag should be located approximately 4" above the equipment floor. The D.I.D. bag must be adequately buffered to prevent contact with sharp or rough edges that may puncture the bag.

Maximum D.I.D. bag inflation of 2 PSI.

The rear of load should extend to the 48' mark of 53' equipment

PALLETIZED CASE GOODS – SPLIT LOAD PATTERN



D.I.D. BAGS MUST NOT BE USED IN VOID SPACES IN EXCESS OF 12", MUST NOT CONTACT FLOOR OF TRAILER OR PALLET AFTER INFLATION, MUST BE ADEQUATELY BUFFERED WHEN IN CONTACT WITH ROUGH SURFACES, AND SHOULD BE INFLATED BETWEEN 1 & 1 1/2 PSI.

Palletized Case Goods (2 - 2 Offset Pattern) – Two Layers High Braced with D.I.D. Bags

Palletized case goods unitized with shrink-wrap or stretch-wrap in accordance with manufacturer's specifications.

D.I.D. bags must be a minimum of 48" x 96" (level 1). Three D.I.D. bags are utilized for load securement; one bag each is placed vertically at nose section, mid-section and rear of load. The three vertical bags include both the top and bottom layer palletized units.

Pallets are loaded in a 2-2 offset pattern. The pallet's 48" dimension is loaded lateral in 100-102" width equipment and the 40" dimension is loaded lateral in 96-98" width equipment. Loaded lateral = perpendicular to equipment sidewalls. The load plan should minimize lateral void space.

When product underhang of the pallet exists it's possible for the product to migrate or move on the pallet. Any product movement has the potential to cause product damage. Product underhang of the pallet is considered void space and should be filled with recommended dunnage material.

Disposable Inflatable Dunnage (D.I.D.) Bag - Notes

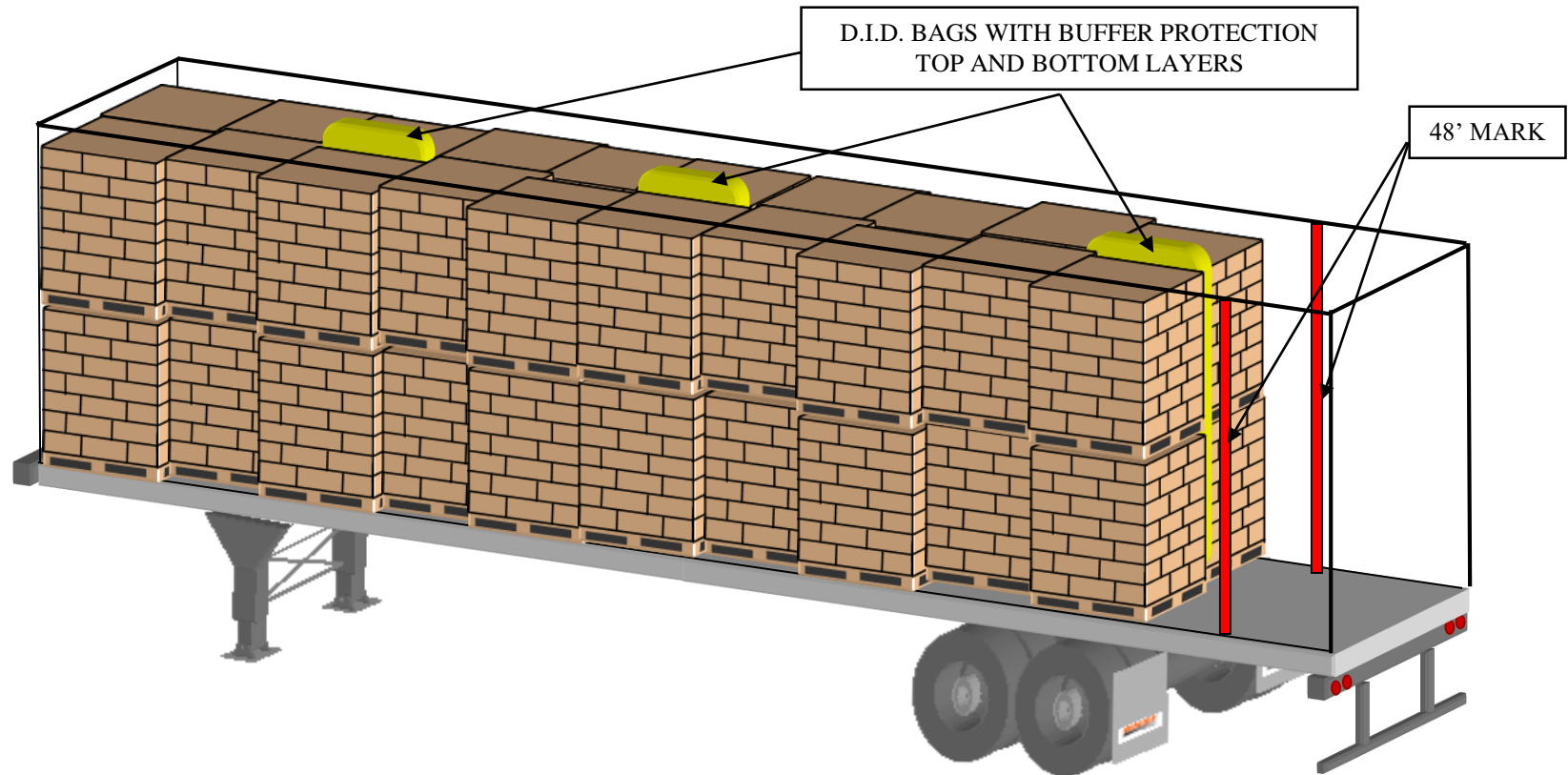
The D.I.D. bag must not be used in a void space in excess of 12". If the void space exceeds 12" width, additional full size void fillers must be placed along side the D.I.D. bag.

After inflation, the D.I.D. bag should be located approximately 4" above the equipment floor. The D.I.D. bag must be adequately buffered to prevent contact with sharp or rough edges that may puncture the bag.

Maximum D.I.D. bag inflation of 2 PSI.

Leave approximately 24" space between the rear of the load and the equipment doors.

PALLETIZED CASE GOODS (2-2 OFFSET) – TWO LAYERS HIGH



NOTE: D.I.D. BAGS MUST NOT BE USED IN VOID SPACES IN EXCESS OF 12", MUST NOT CONTACT FLOOR OF TRAILER OR PALLET AFTER INFLATION, MUST BE ADEQUATELY BUFFERED WHEN IN CONTACT WITH ROUGH SURFACES, AND SHOULD BE INFLATED NO MORE THAN 1-2 PSI. IF CENTERLINE VOID EXCEEDS 12" ADDITIONAL VOID FILLERS MUST BE PLACED ALONG SIDE D.I.D. BAG.

Palletized Case Goods (Single Row) – Braced with Wood Floor Blocking

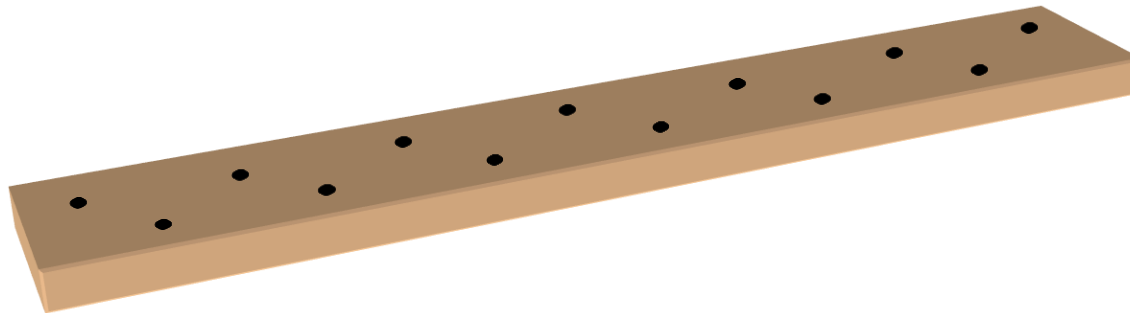
The palletized case goods are unitized with either shrink-wrap or stretch-wrap in accordance with the manufacturer's specifications.

Palletized case goods with high density weight are loaded in one row from nose to rear of equipment. It's critical that palletized units are laterally centered in the trailer/container in order to maintain proper weight distribution.

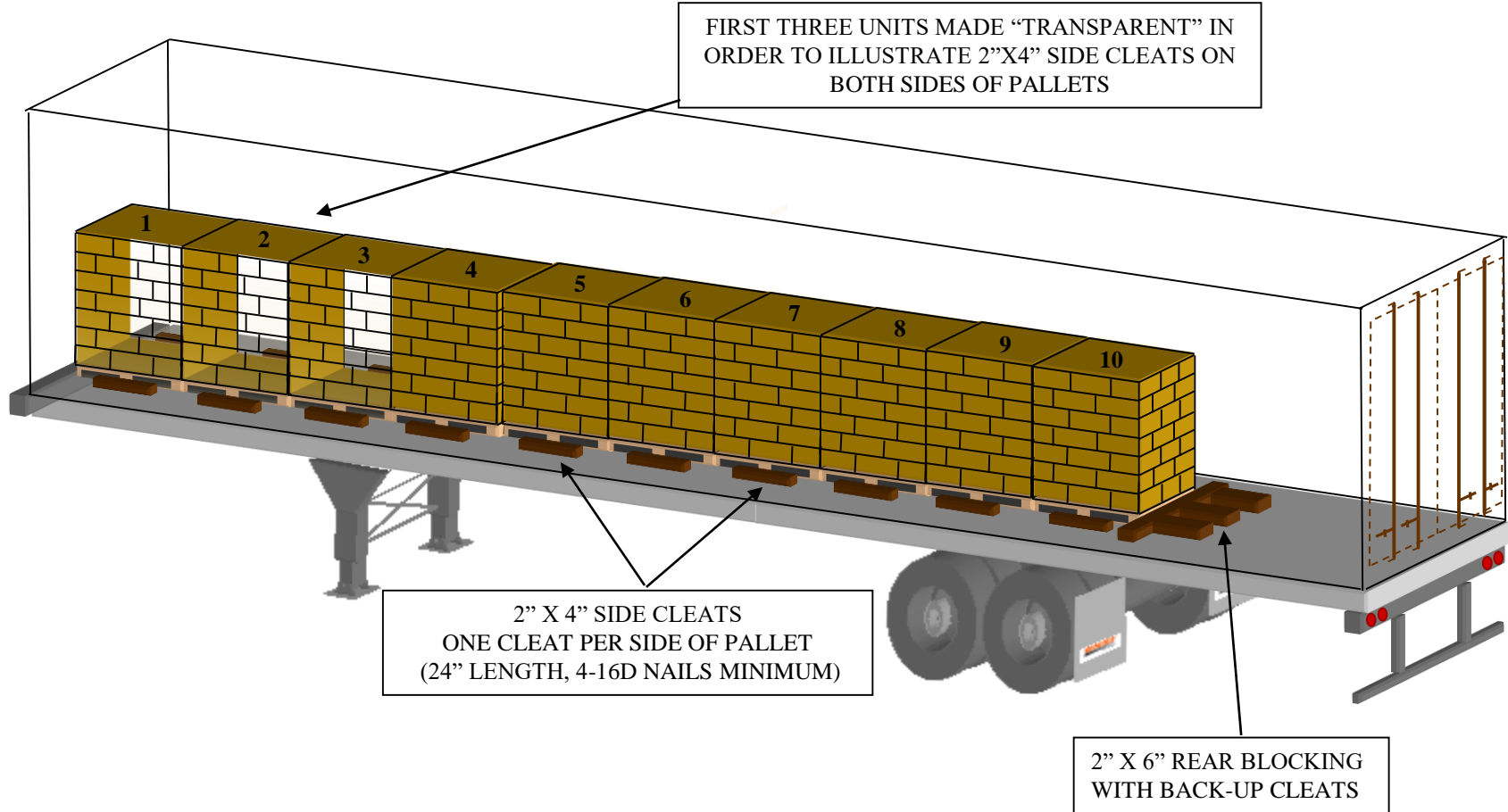
Wood Floor Blocking/Bracing

The rear of the load is secured with 2"x6" wood floor blocking. At rear of load, the wood floor blocking runs the entire width of the rear pallet and is reinforced with three 2"x6"x18" back-up cleats. The wood floor blocking is secured with 16d nails that are spaced four-six inches apart in a staggered pattern. A staggered nail pattern prevents the nails from splitting the wood. The sides of pallets are secured with 2"x4" wood floor blocking. The 2"x4"x24" side cleats (two per pallet) are each secured with a minimum of four 16d nails that are placed in a staggered pattern.

FLOOR BLOCKING SHOULD BE SECURELY NAILED TO THE TRAILER FLOOR AND MUST PENETRATE THE TRAILER FLOOR TO A DEPTH OF 1" OR MORE. THE NAILS SHOULD BE SPACED FOUR-SIX INCHES APART IN A STAGGERED PATTERN (SEE BELOW).



PALLETIZED CASE GOODS – SINGLE ROW



Palletized Case Goods (2-2 Offset with Singles) – Braced with Wood Floor Blocking

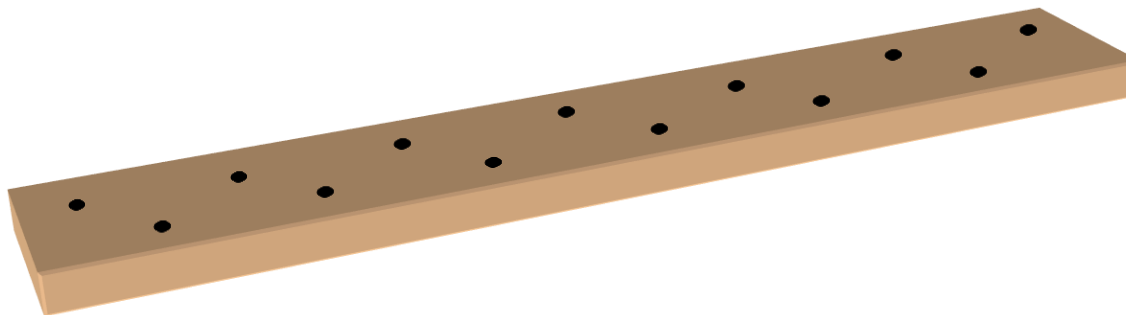
The palletized case goods are unitized with either shrink-wrap or stretch-wrap in accordance with the manufacturer's specifications. The pallets are loaded in a 2-2 offset pattern, while single units are laterally centered.

Wood Floor Blocking/Bracing

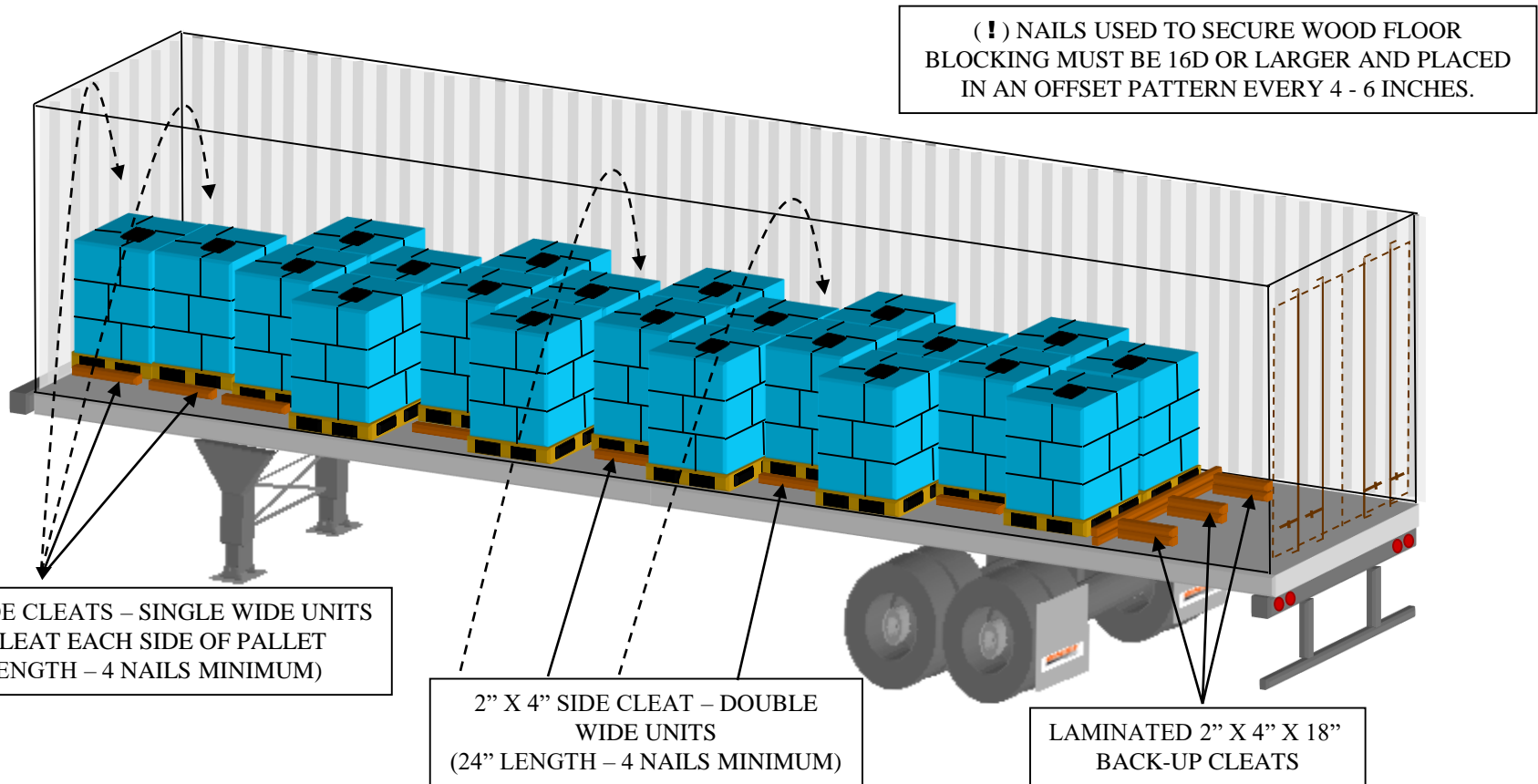
The rear of the load is secured with 2"x4" wood floor blocking. At rear of load, the laminated wood floor blocking runs the entire width of the equipment and is reinforced with three laminated 2"x4"x18" back-up cleats. The wood floor blocking is secured with 16d nails that are spaced four-six inches apart in a staggered pattern. A staggered nail pattern prevents the nails from splitting the wood. The sides of the pallets are secured with 2"x4" wood floor blocking. The 2"x4"x24" side cleats are each secured with a minimum of four 16d nails that are placed in a staggered pattern. One side cleat is required for double-wide units and two side cleats (one each side) are required for the single-wide units.

Laminated Wood Floor Blocking: One piece of lumber is nailed to the equipment floor. A second piece of lumber is nailed on top of the first piece of lumber.

FLOOR BLOCKING SHOULD BE SECURELY NAILED TO THE TRAILER FLOOR AND MUST PENETRATE THE TRAILER FLOOR TO A DEPTH OF 1" OR MORE. THE NAILS SHOULD BE SPACED FOUR-SIX INCHES APART IN A STAGGERED PATTERN (SEE BELOW).



PALLETIZED CASE GOODS – 1-2 UNITS WIDE



ALL UNITS MUST BE PROPERLY STRETCH-WRAPPED TO MAINTAIN ADEQUATE VERTICAL ALIGNMENT DURING THE TRANSPORTATION CYCLE (3 TO 4 WRAPS PER UNIT). SINGLE UNITS MUST BE HEAVILY STRETCH-WRAPPED TO OBTAIN OPTIMUM RESTRAINING CAPACITY.

Palletized Case Goods of Produce (2 - 2 Offset Pattern) – TCI Rear Gate with Two Nylon Web Strap Assemblies

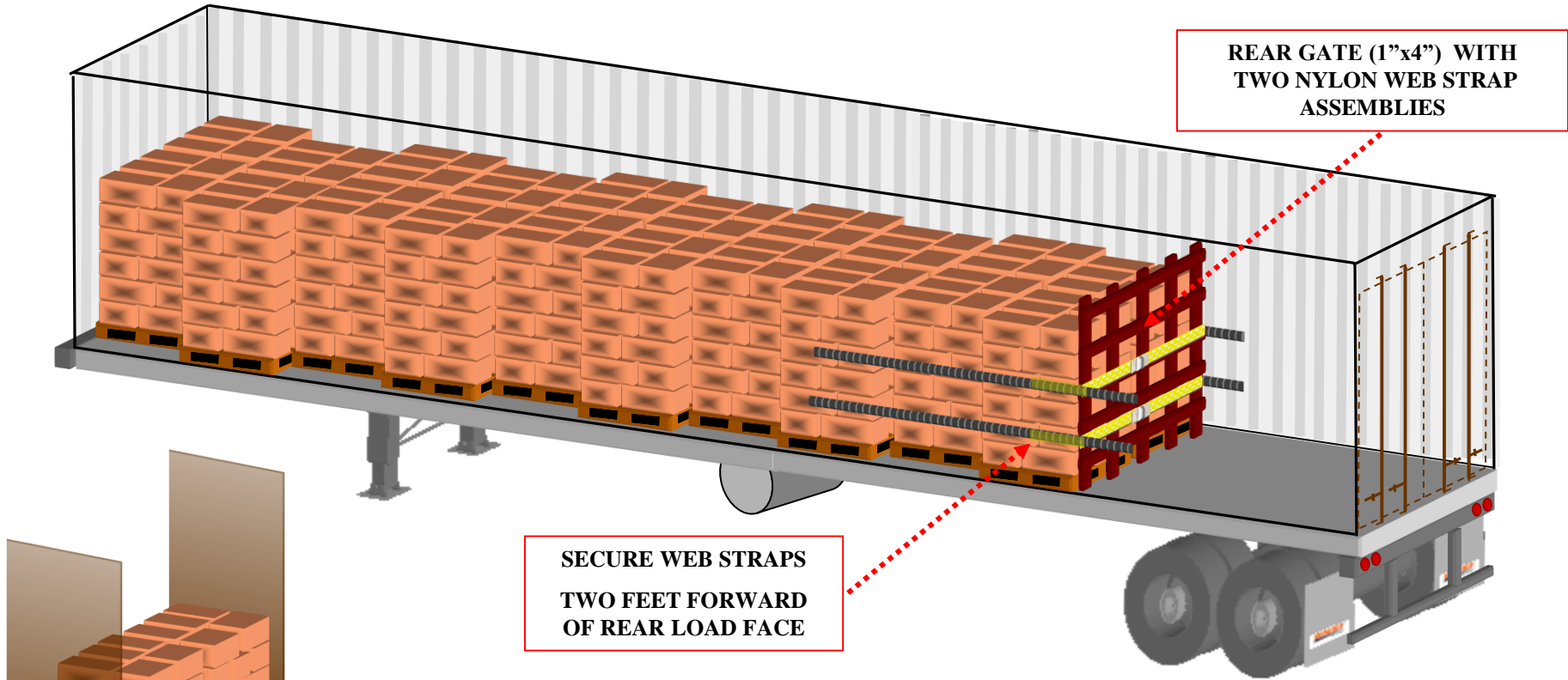
Palletized case goods of produce are loaded tightly together in a 2-2 offset pattern. The pallet's 48" dimension is loaded lateral in 100-102" width equipment and the 40" dimension is loaded lateral in 96-98" width equipment. Loaded lateral = perpendicular to equipment sidewalls. The load plan should minimize lateral void space.

Important! If the lateral void of palletized produce is eight-plus inches (see lower-left corner of diagram illustration), this loading method is NOT approved. When the lateral void is eight-plus inches, D.I.D. bags are required to supplement the rear gate and nylon web strap assemblies.

Rear Gate with Nylon Web Strap Assemblies

The rear gate constructed of 1" x 4" lumber is placed directly against the palletized product at the rear of the load. The two-inch nylon web strap assemblies are secured to the equipment E-track belt rail approximately two feet forward of the rear load face. The two nylon web strap assemblies should be tightly tensioned across the rear wooden gate.

REEFER UNIT – PALLETIZED CASE GOODS OF PRODUCE



REAR GATE (1"x4") WITH TWO NYLON WEB STRAP ASSEMBLIES

SECURE WEB STRAPS TWO FEET FORWARD OF REAR LOAD FACE

Lateral Void Less than 8" APPROVED

BLOCKING/BRACING OF INTERMODAL SHIPMENT

1.) Palletized Case Goods Loaded in a 2-2 Offset Pattern. Longest Side of Pallet Loaded Crosswise in Reefer Trailer. **This Diagram is NOT Approved when the Lateral Void is 8+"** (see Illustration to Left).

2.) Secure Nylon Web Strap (2") Assemblies to E-Track Belt Rails Approximately Two Feet Forward of the Rear Load Face. Tension Web Straps Across Gate.

Palletized Case Goods of Produce (2 - 2 Offset Pattern with Singles) – TCI Rear Gate with Two Nylon Web Strap Assemblies & D.I.D. Bags

Palletized case goods of produce are loaded tightly together in a 2-2 offset pattern, while singles are laterally centered. The pallet's 48" dimension is loaded lateral in 100-102" width equipment and the 40" dimension is loaded lateral in 96-98" width equipment. Loaded lateral = perpendicular to equipment sidewalls. The load plan should minimize lateral void space.

D.I.D. bags must be a minimum of 48" x 96" (level 1). Two D.I.D. bags are utilized for load securement; the first is placed in the center of the load and the second at the rear of the load. If the lateral void of palletized product is not eight-plus inches, D.I.D. bags are not required.

Rear Gate with Nylon Web Strap Assemblies

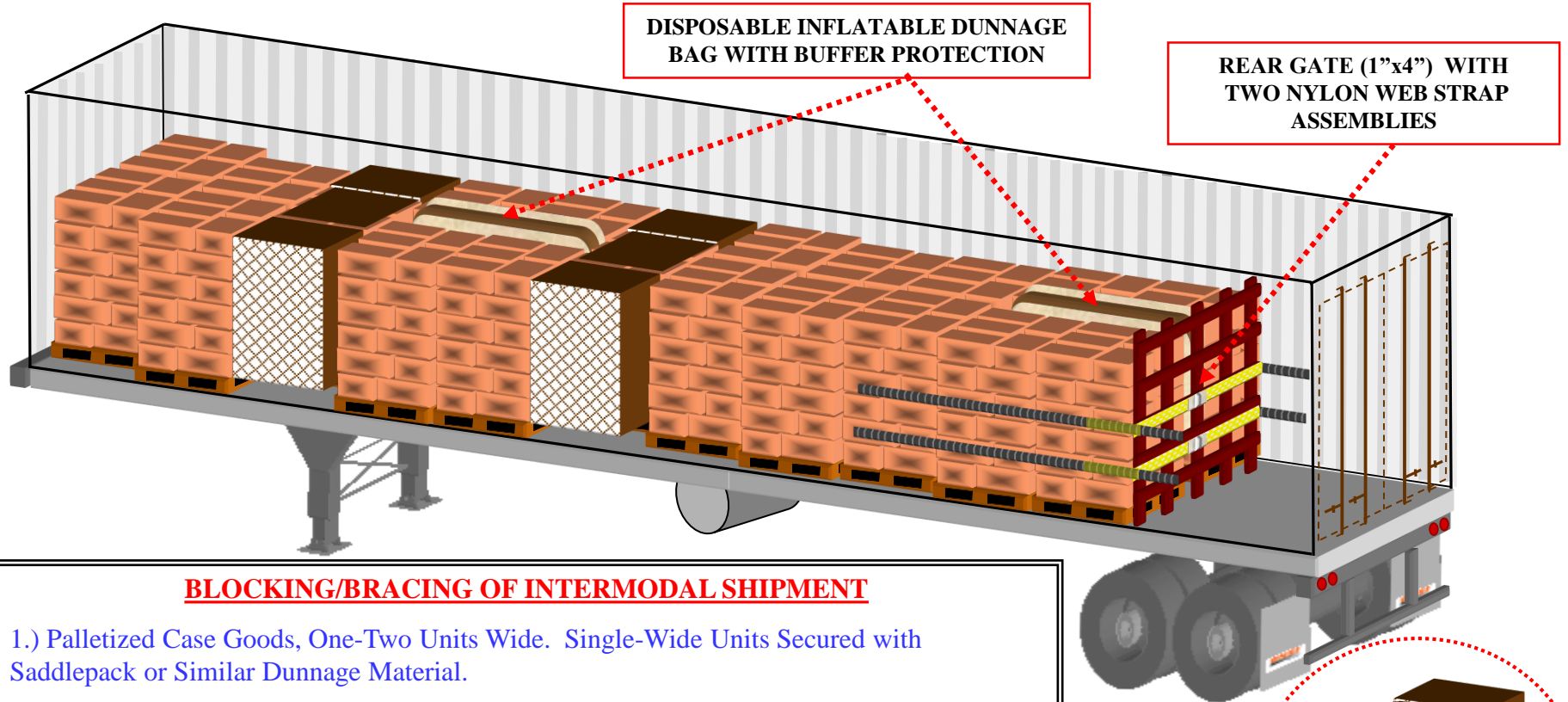
The rear gate constructed of 1" x 4" lumber is placed directly against the palletized product at the rear of the load. The two-inch nylon web strap assemblies are secured to the equipment E-track belt rail approximately two feet forward of the rear load face. The two nylon web strap assemblies should be tightly tensioned across the rear wooden gate.

Disposable Inflatable Dunnage (D.I.D.) Bag - Notes

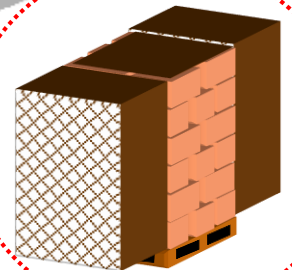
The D.I.D. bag must not be used in a void space in excess of 12". If the void space exceeds 12" width, additional full size void fillers must be placed along side the D.I.D. bag.

After inflation, the D.I.D. bag should be located approximately 4" above the equipment floor. The D.I.D. bag must be adequately buffered to prevent contact with sharp or rough edges that may puncture the bag.

Maximum D.I.D. bag inflation of 2 PSI.

REEFER UNIT – PALLETIZED CASE GOODS OF PRODUCE**BLOCKING/BRACING OF INTERMODAL SHIPMENT**

- 1.) Palletized Case Goods, One-Two Units Wide. Single-Wide Units Secured with Saddlepack or Similar Dunnage Material.
- 2.) D.I.D. Bags (Level 1) With Buffer Protection that Fit Face-of-Load to Restrict Product Movement. The D.I.D. Bags Should Not Fill More Than 12" of Void Space When Fully Inflated. When Lateral Center Void Exceeds 12", Additional Void Fillers Required with D.I.D. Bag.
- 3.) Secure Nylon Web Strap (2") Assemblies to E-Track Belt Rails Approximately Two Feet Forward of Rear Load Face. Tension Web Straps Across Gate.

**SINGLE
WIDE
PALLET**

Palletized Case Goods of Produce (2 - 2 Offset Pattern) – TCI Rear Gate with Two Nylon Web Strap Assemblies & D.I.D. Bags

Palletized case goods of produce are loaded tightly together in a 2-2 offset pattern. The pallet's 48" dimension is loaded lateral in 100-102" width equipment and the 40" dimension is loaded lateral in 96-98" width equipment. Note: Loaded lateral = perpendicular to equipment sidewalls. The load plan should minimize lateral void space.

D.I.D. bags must be a minimum of 48" x 96" (level 1). Two D.I.D. bags are utilized for load securement; the first is placed in the center of the load and the second at the rear of the load. *If the lateral void of palletized product is less than inches, D.I.D. bags are not required.*

Single-wide pallets should be blocked/braced with saddle-pack fillers.

Rear Gate with Nylon Web Strap Assemblies

The rear gate constructed of 1" x 4" lumber is placed directly against the palletized product at the rear of the load. The two-inch nylon web strap assemblies are secured to the equipment E-track belt rail approximately two feet forward of the rear load face. The two nylon web strap assemblies should be tightly tensioned across the rear wooden gate.

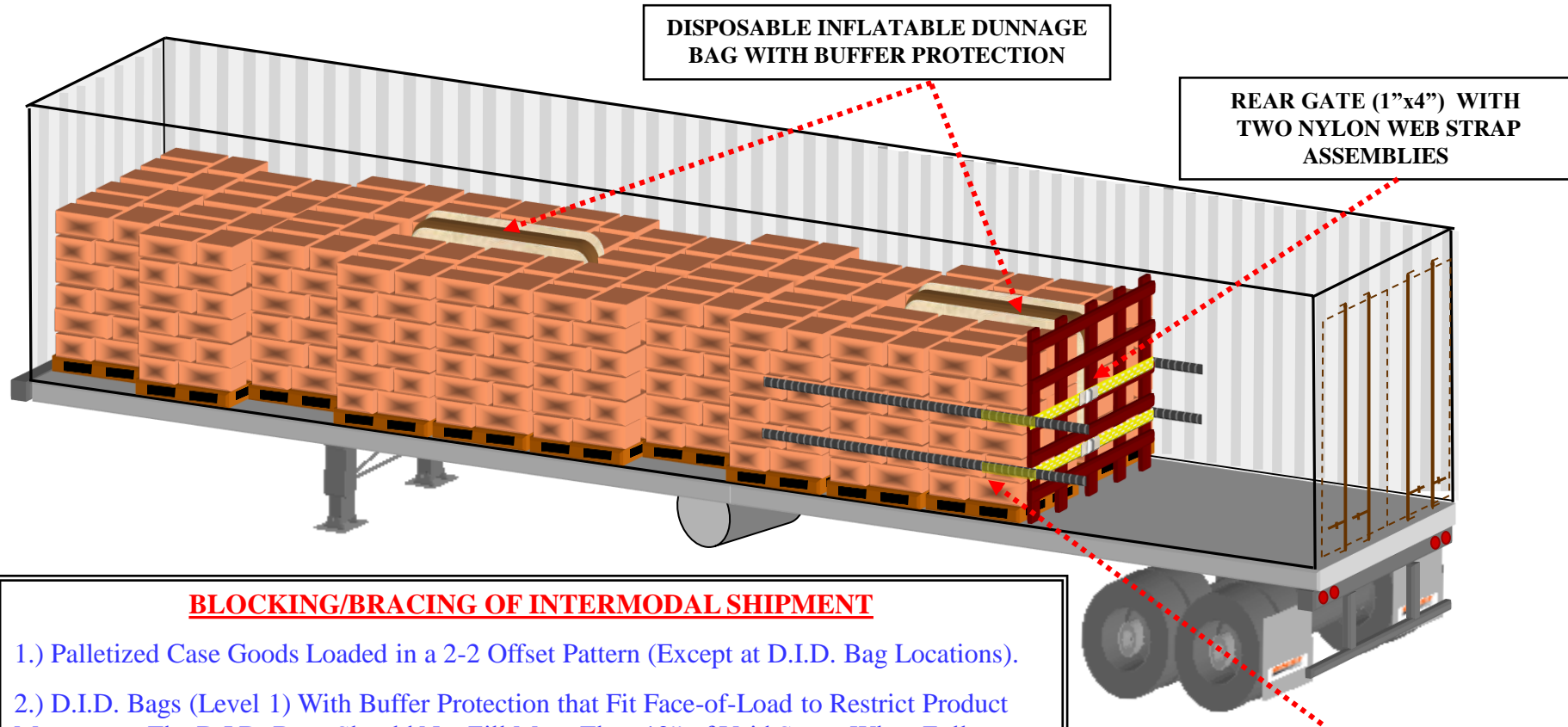
Disposable Inflatable Dunnage (D.I.D.) Bag - Notes

The D.I.D. bag must not be used in a void space in excess of 12". If the void space exceeds 12" width, additional full size void fillers must be placed along side the D.I.D. bag.

After inflation, the D.I.D. bag should be located approximately 4" above the equipment floor. The D.I.D. bag must be adequately buffered to prevent contact with sharp or rough edges that may puncture the bag.

Maximum D.I.D. bag inflation of 2 PSI.

REEFER UNIT – PALLETIZED CASE GOODS OF PRODUCE



DISPOSABLE INFLATABLE DUNNAGE BAG WITH BUFFER PROTECTION

REAR GATE (1"x4") WITH TWO NYLON WEB STRAP ASSEMBLIES

SECURE WEB STRAPS TWO FEET FORWARD OF REAR LOAD FACE

BLOCKING/BRACING OF INTERMODAL SHIPMENT

- 1.) Palletized Case Goods Loaded in a 2-2 Offset Pattern (Except at D.I.D. Bag Locations).
- 2.) D.I.D. Bags (Level 1) With Buffer Protection that Fit Face-of-Load to Restrict Product Movement. The D.I.D. Bags Should Not Fill More Than 12" of Void Space When Fully Inflated. When Lateral Center Void Exceeds 12", Additional Void Fillers Required with D.I.D. Bag.
- 3.) Secure Nylon Web Strap (2") Assemblies to E-Track Belt Rails Approximately Two Feet Forward of the Rear Load Face. Tension Web Straps Across Gate.

ROLL AND FLAT STOCK PAPER PATTERNS



Rolled paper defined as a “restricted commodity” on BNSF Railway. See BNSF Intermodal Rules & Policies Guide Item 43.

Roll Paper – 72” Diameter - 70” to 98” Width – Split Loading Pattern

8 Floor Spots - Load Not to Exceed 45,000 LBS

This method is for 72” diameter roll paper or pulp board loaded on end in a 1-1 offset pattern in a container for intermodal service. **Plan the load to equalize the weight on each side of the container.** Roll weights vary and will require pre-planning. A balanced load is required for the stability and success of this loading pattern.

The load is divided into two sections, four rolls per section. Place two 3’ rubber mats side-by-side 12” apart on the floor at the nose of the container, 6” longer than length of rolls (approximately 3’ x 23’ length). **Rubber matting must be one continuous length.** Load the first roll tightly starting against the nose wall and one sidewall using a 1-1 offset pattern. Place the second roll tightly lengthwise against first roll and opposite sidewall. Load the third and fourth roll in the same manner as illustrated in diagram.

A minimum of 3 feet of void is required between the cargo and the container doors. Position the rear section to obtain the proper weight distribution and maintain the 3’ void at the rear of the container.

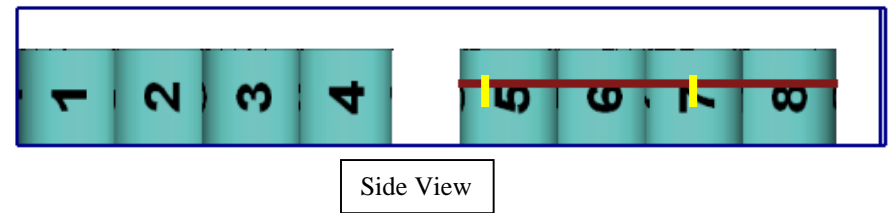
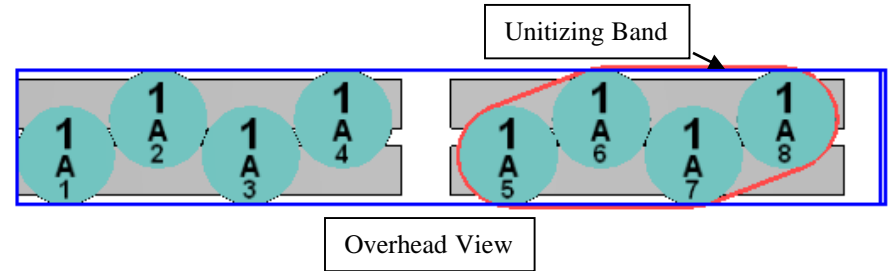
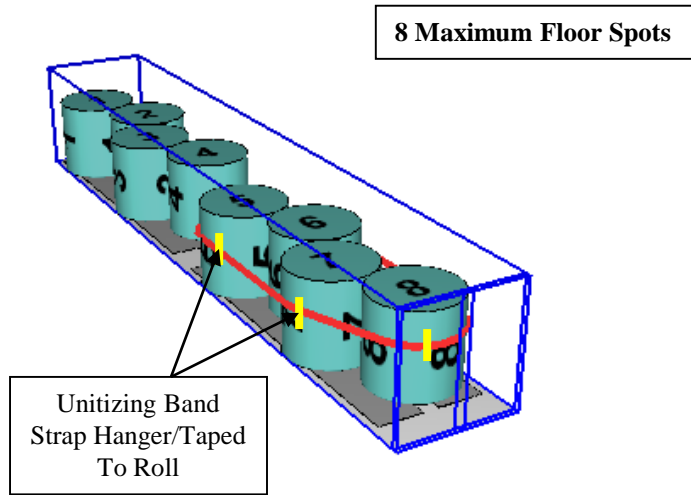
The rear section consisting of four rolls is loaded in the same manner as above (at the container doors). Prior to loading the rolls, tape an approved polyester or equivalent poly strap to the container sidewalls for unitizing the rear section. Place rubber matting in place and load the rear section in a 1-1 offset pattern. The strap must be level and positioned 18” to 24” from the top of the roll. Tighten unitizing strap and secure in place with fiberboard strap hangers or looped cord straps taped to several rolls.

Rubber Mat Requirements

The rubber matting must be a minimum of 3’ wide and extend a minimum of 6” beyond the rolls at each end of each mat except at the nose wall. As an alternative, 4’ wide matting may be utilized instead of the 3’ mat. The lengths will remain the same.

The following AAR approved rubber matting may be used with this loading method.

- TransMat 6900 [3mm (0.125”) thick]
- Rubber Restraint Mat BC548 [3mm (0.125”) thick]
- Load Grip 5 [2mm (0.080”) thick]
- TransMat 7513 [3mm (0.125”) thick]
- Load Lock [3mm (0.125”) thick]
- Brown Bear – Friction Mat 101 [2mm (0.080”) thick] or {3mm (0.125”) thick}



8 Maximum Floor Spots - Split Load
72" Diameter x 70" to 98" Width Rolls – Average Roll Weight - 5,500 lbs
Roll Weights May Vary – Load Not To Exceed 45,000 LBS

Each Section Stowed in 1 -1 Offset Pattern on Top of 2 – 3' x 3MM Rubber Mats
Doorway Section Unitized with Caristrap or 1-1/4" Equivalent Poly Strapping
Secured With Strap Hangers or Tape
Rear Section Load 26' 10" From Nosewall
Rubber Mat Must Extend 12" Beyond Rolls
Minimum 3' Void Between Doors & Rolls

California 40' Bridge Law – Loading Pattern Based on 456" Wheelbase



Rubber Matting



Poly Strapping

Roll Paper – 72” Diameter - 30” to 40” Width - Rolls Stowed on Risers Secured with E-Bracing - Load Not to Exceed 45,000 LBS

This loading method is a double-layer, 1-1 offset pattern for 72” diameter roll paper or pulp board loaded on end in a steamship container for intermodal service.

The rolls for each layer are stowed on top of two 2” x 4” x 48” wood risers to facilitate loading and unloading. Load the first double-stack tightly, starting against the nose wall and one sidewall using a 1-1 offset pattern. Place the second double-stack tightly against first and against opposite sidewall. Load the remaining double-stacks in the same manner.

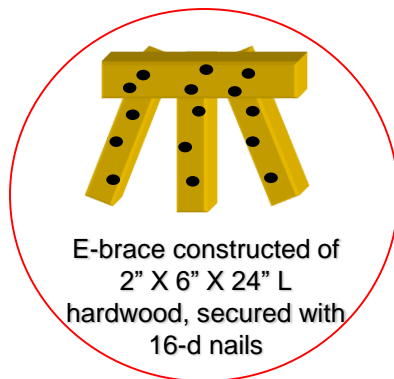
The last stack must be unitized to prevent movement of the second layer prior to applying the floor blocking. The rear stack may be unitized by either a core insert placed through the core of both rolls, or unitized with three 1-1/4” steel bands or equivalent poly strapping as illustrated in the attached diagram.

The load is secured with a minimum of three sets of 2” x 6” E-Braces securely nailed to the container floor.

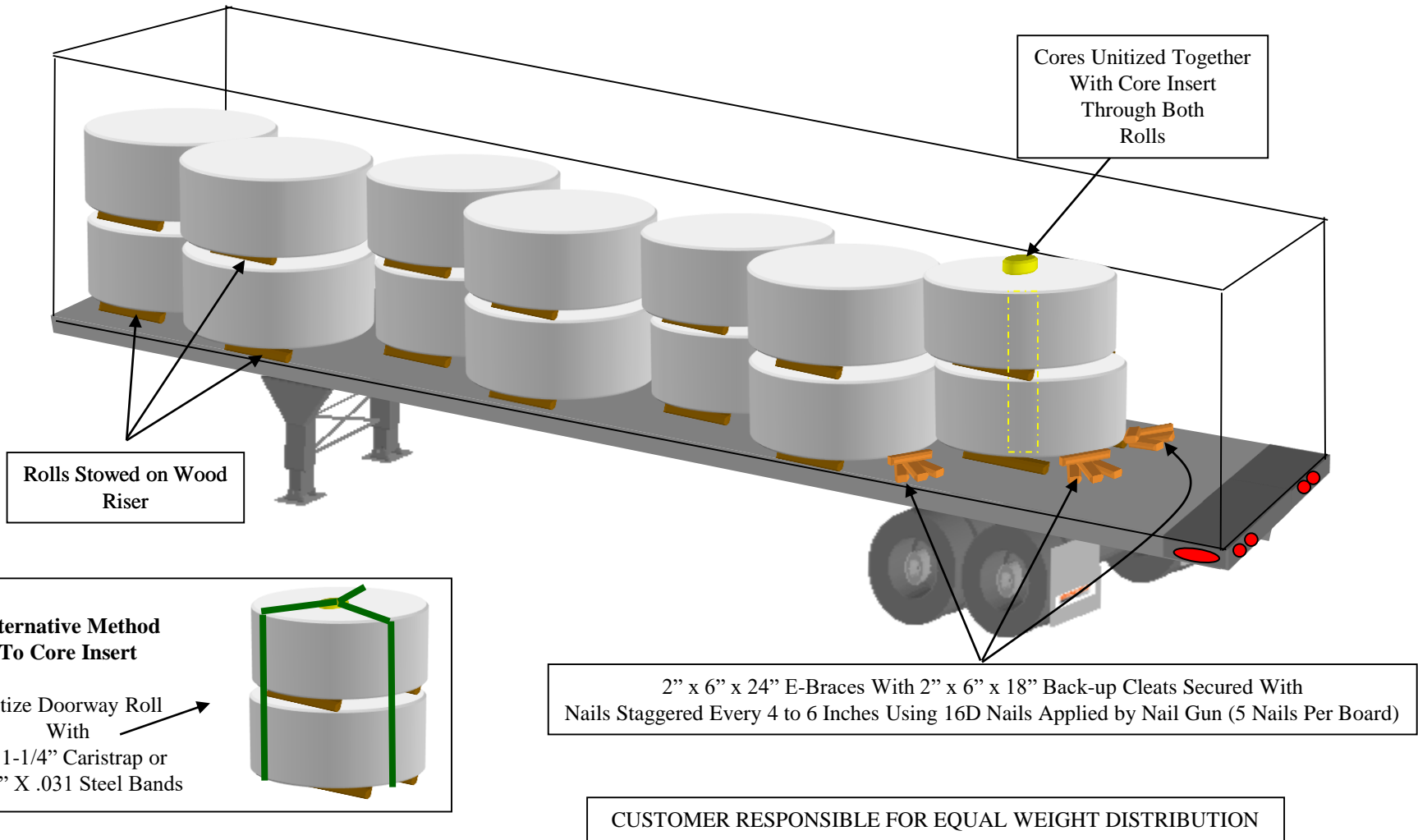
E-Bracing

The “E” braces are constructed from four pieces of 2” x 6” x 24” lumber that is free of knots, splits, or other defects. The blocking is assembled as shown in the sketch below. The cross brace is placed on top of the three backup cleats and nailed in place with five 16d or larger nails.

Each backup cleat is nailed to the floor with five 16d or larger nails evenly spaced along each backup cleat in an off set pattern as shown in the sketch below. One 16d nail has approximately holding power of 1,000 lbs.; use adequate number of nails for the weight involved.



**LOADING METHOD FOR 72" DIAMETER ROLLS OF PAPER IN 45' STEAMSHIP CONTAINER
14 – 72" x (30 to 40") ROLLS STOWED IN A 1-1 OFF SET PATTERN SECURED WITH 2X6 WOOD E-BRACES**



Roll Paper – 40” to 45” Diameter Loaded in a 2-1-2 Pattern - Secured with Rubber Mats (32 Floor Spots)

This method is restricted to a single layer, 2-1-2 pattern for 40” to 45” diameter rolls loaded into a 53’ container for intermodal service.

The rolls are loaded from the nose in a tightly nested 2-1-2 pattern to within five feet of the container doors. The first 5 rolls adjacent to the nose and the last 11 rolls at the doorway are stowed on top of 3’ rubber matting. In addition the last 11 rolls at the doorway are unitized with a single strap.

Prior to loading the nose section, place the 3’ rubber matting equal to the length of the first 5 rolls 12” apart (side-by-side). Load the rolls tightly in a 2-1-2 pattern. Prior to loading the last 11 rolls, place rubber matting in place and tape an approved polyester or equivalent non-metallic strap to the container sidewalls for unitizing the rear section. The unitizing strap must be level and positioned 12” from the top of the rolls. After loading the rolls, tighten the unitizing strap snugly and secure in place with fiberboard strap hangers or looped cord straps taped to several rolls. **A minimum of 3 feet of void is required between the cargo and the container doors. Rubber matting must be one continuous piece.**

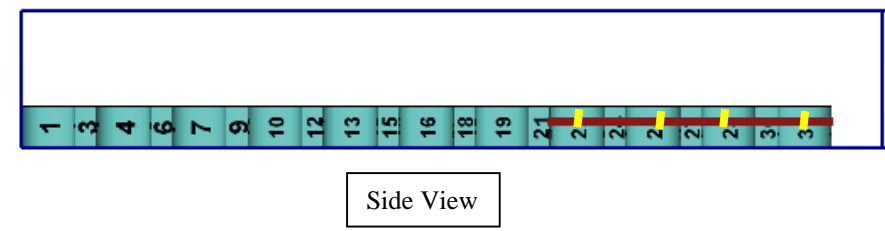
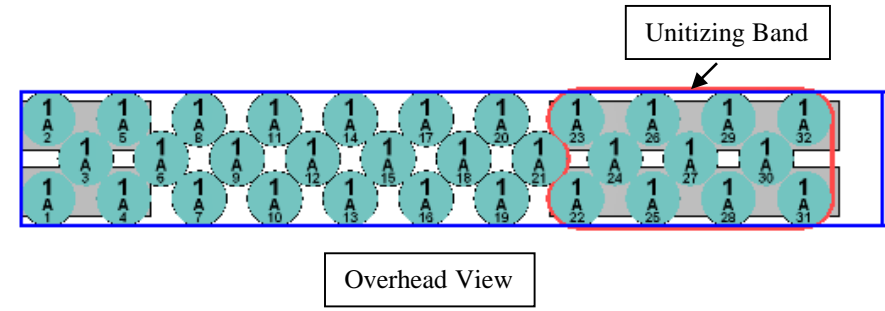
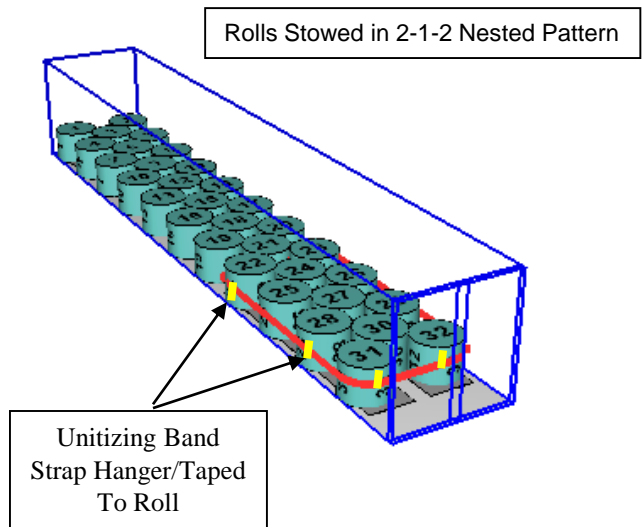
Rubber Mat Requirements

The rubber matting must be a minimum of 3’ wide and extend a minimum of 6” beyond the doorway rolls. The following AAR approved rubber matting may be used with this loading method.

- TransMat 7513 [3mm (0.125”) thick]
- TransMat 6900 [3mm (0.125”) thick]
- Rubber Restraint Mat BC548 [3mm (0.125”) thick]
- Load Grip 5 [2mm (0.080”) thick]
- Load Lock [3mm (0.125”) thick]
- Brown Bear – Friction Mat 101 [2mm (0.080”) thick] or {3mm (0.125”) thick]

Alternative Securement Method

Laminated 2”x 4” x 96” floor blocking with laminated 2”x 4” x 18” back-up cleats may be substituted for rubber matting. Floor blocking at the rear of the load must be secured with adequate number of 16D nails staggered every 4” to 6”.



Rubber Matting



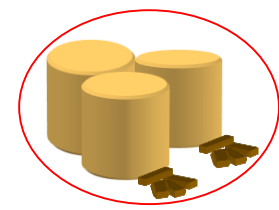
32 Floor Spots in 2-1-2 Nested Pattern
40 to 45" Diameter x 40" Width Rolls – Average Roll Weight 1,400 lb
Load Not To Exceed 45,000 lbs

Rolls Stowed on Top of 2 – 3' x 3MM Rubber Mats
First 5 Rolls (Nose) & Last 11 Rolls (Doorway) Loaded on Rubber Matting
Last 11 Rolls (Doorway) Unitized with Caristrap or 1-1/4" Equivalent Poly Strapping
Secured With Strap Hangers or Tape
Rubber Mat Must Extend 12" Beyond Rolls - Minimum 3' Void Between Doors & Rolls

Note: 2x6 E-Braces Secured With 16D Nails Staggered Every 4" May Be Substituted For Rubber Matting



Poly Strapping



Roll Paper – 40” to 45” Diameter Loaded in a 2-1-2 Pattern - Secured with E-Braces (31 Floor Spots)

This method is for roll paper or pulpboard loaded on end in a 2-1-2 pattern, with an incomplete second layer for 40” to 45” diameter rolls loaded into a 53’ container for intermodal service.

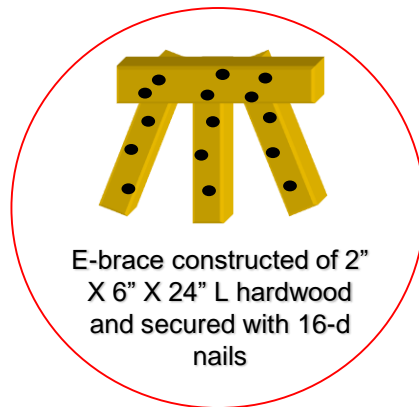
The rolls are loaded from the nosewall in a tightly nested 2-1-2 pattern throughout the container. The incomplete layer is loaded approximately in the center of the container secured by blocking rolls at both the front and rear (see diagram illustration). The blocking rolls must extend a minimum of 6” above the bottom of the adjacent top-layer rolls. This is accomplished by loading rolls of smaller width in the floor layer or using roll risers under the blocking rolls. Roll risers are a minimum of 6” x 6” x 30” corrugated fiberboard or equivalent material placed longitudinal in the container. Corrugated fiberboard risers must be positioned with the corrugations vertical. Minimum crush strength required is 6,000 lbs/ft for the risers.

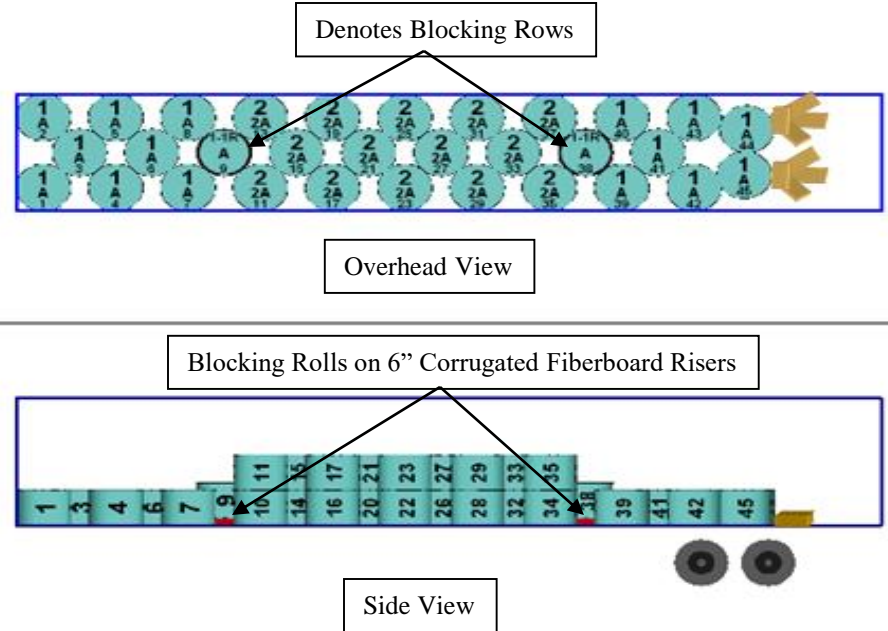
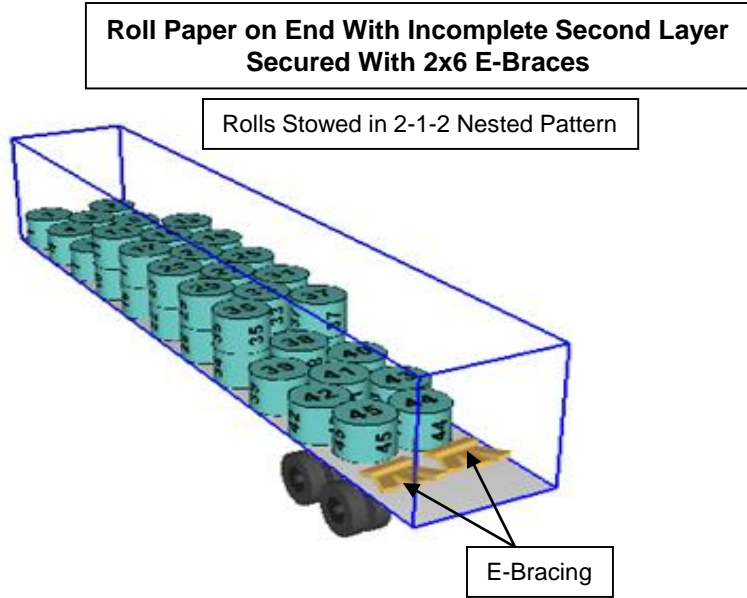
The rear of the load is secured with two sets of 2” x 6” E-Braces securely nailed to the container floor.

E-Bracing

The “E” braces are constructed from four pieces of 2” x 6” x 24” lumber that is free of knots, splits, or other defects. The blocking is assembled as shown in the sketch below. The crossbrace is placed on top of the three backup cleats and nailed in place with five 16d or larger nails.

Each backup cleat is nailed to the floor with five 16d or larger nails evenly spaced along each backup cleat in an offset pattern as shown in the sketch below.





2-1-2 Nested Pattern With Incomplete Second Layer Secured With 2x6 E-Bracing
45 Rolls - 40 to 45" Diameter x 30" Width Rolls – Average Roll Weight 1,000 lb
Load Not To Exceed 45,000 lbs

Rolls Stowed in a 2-1-2 Nested Pattern With Incomplete Second Layer
 Incomplete Layer Loaded Approximately In Center of Container Secured With
 Blocking Rows Both Front and Rear as Illustrated Placed on Six Inch Corrugated
 Fiberboard Risers

Rear of Load Braced With 2x6 E-Braces Secured With 16D Nails Staggered Every 4"



E-Brace Constructed of
 2" X 6" X 24" L Hardwood,
 With 16-d Nails



Corrugated Risers

Roll Paper – 50” Diameter - 50” to 70” Width – Split Loading Pattern

11 Floor Spots - Load Not to Exceed 45,000 LBS

This method is for 50” diameter roll paper or pulpboard loaded on end in a 1-1 offset pattern in a container for intermodal service. **Plan the load to equalize the weight on each side of the container.** A balanced load is required for the stability and success of this loading pattern.

The load is divided into two sections, five rolls in the front section, and six rolls in the doorway section. Place two 3’ rubber mats 12” apart (side-by-side) on the floor at the nose of the container, 6” longer than length of rolls. **Rubber matting must be one continuous length.** The first roll is centered against the nosewall with 3” x (void width) x 36” fiberboard dunnage filling the lateral void on each side of the roll. To facilitate the 1-1 offset pattern a 4” thick fiberboard filler is placed between roll 2 and the left sidewall. Place the second roll tightly lengthwise against first roll and sidewall. Load the third, fourth, and fifth roll in the same manner, to opposite sidewalls as illustrated in loading diagram.

A minimum of 3 feet of void is required between the cargo and the container doors. Position the rear section to obtain the proper weight distribution and maintain the 3’ void at the rear of the container.

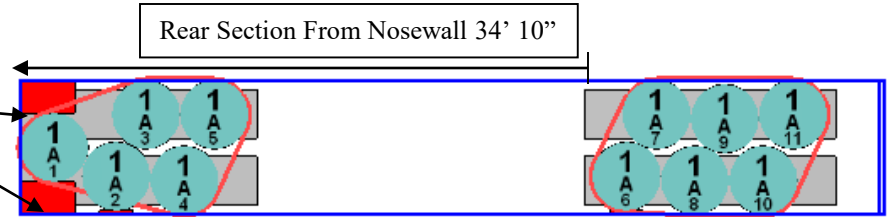
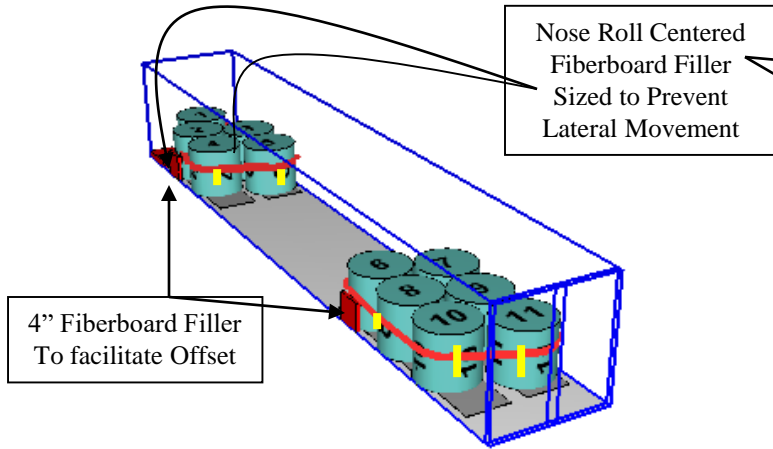
The rear section consists of six rolls. Prior to loading the rolls, tape an approved polyester or equivalent poly strap to the container sidewalls for unitizing the rear section. The strap must be level and positioned 18” to 24” from the top of the roll. Lay rubber matting in place and load the rear section. To facilitate the 1-1 offset pattern a 4” thick fiberboard filler is placed between roll 6 and the left sidewall. Load rolls tightly lengthwise alternating sidewalls. Tighten unitizing strap and secure in place with fiberboard strap hangers or looped cord straps taped to several rolls.

Rubber Mat Requirements

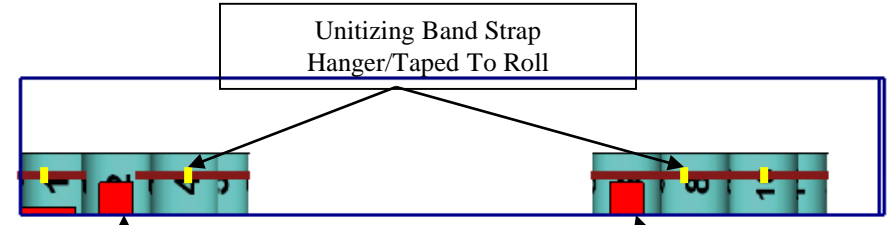
The rubber matting must be a minimum of 3’ wide and extend a minimum of 6” beyond the rolls at each end of each mat except at the nosewall. As an alternative, 4’ wide matting may be utilized instead of the 3’ mat. The lengths will remain the same.

The following AAR approved rubber matting may be used with this loading method.

- TransMat 7513 [3mm (0.125”) thick]
- TransMat 6900 [3mm (0.125”) thick]
- Rubber Restraint Mat BC548 [3mm (0.125”) thick]
- Load Grip 5 [2mm (0.080”) thick]
- Load Lock [3mm (0.125”) thick]
- Brown Bear – Friction Mat 101 [2mm (0.080”) thick] or {3mm (0.125”) thick]



Overhead View



4" Fiberboard Filler

Side View

4" Fiberboard Filler

11 Floor Spots – Split Loading Plan

50" Diameter x 50" to 70" Width Rolls – Average Roll Weight – 4,000 lbs
Roll Weights May Vary – Load Not To Exceed 45,000 LBS

Nose Section First Roll Centered With Dunnage Each Side
4" Fiberboard Filler for Roll 2 & 6 – Placed between Rolls and Sidewall to Facilitate Offset Pattern
Each Section Stowed in 1 -1 Offset Pattern on Top of 2 – 3' x 3MM Rubber Mats
Rear Section From Nosewall 34' 10"
Both Sections Unitized with Caristrap or 1-1/4" Equivalent Poly Strapping
Secured With Strap Hangers or Tape
Rubber Mat Must Extend 12" Beyond Rolls - Minimum 3' Void Between Doors & Rolls



Rubber Matting



Fiberboard Filler



Poly Strapping

Roll Paper –58” Diameter - 72” to 98” Width – Split Loading Pattern

5 Floor Spots - Load Not to Exceed 45,000 LBS

This method is for 58” diameter roll paper or pulpboard loaded on end in a 1-1 offset pattern in a container for intermodal service. **Plan the load to equalize the weight on each side of the container.** A balanced load is required for the stability and success of this loading pattern.

The load is divided into two sections; two rolls in the front section, and three rolls in the doorway section. Place two 3’ rubber mats 12” apart (side-by-side) on the floor at the nose of the container, 6” longer than length of rolls. **Rubber matting must be one continuous length.** The first roll is centered against the nosewall with 3” x (void width) x 48” fiberboard dunnage filling the lateral void on each side of the roll. Place the second roll tightly lengthwise against first roll and right sidewall as illustrated in diagram.

A minimum of 3 feet of void is required between the cargo and the container doors. Position the rear section to obtain the proper weight distribution and maintain the 3’ void at the rear of the container.

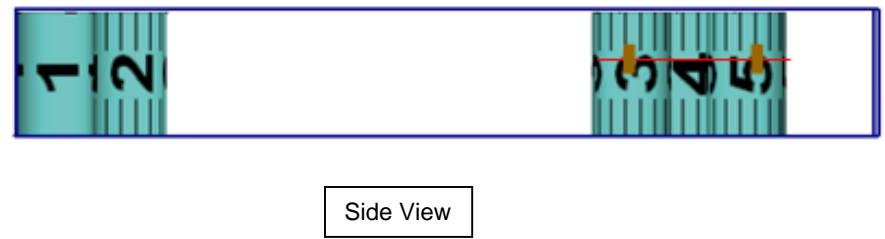
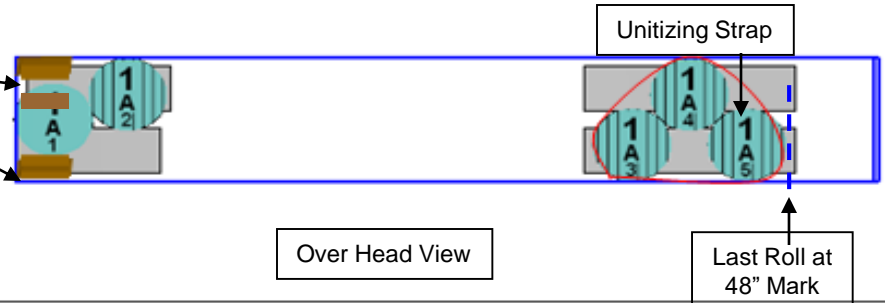
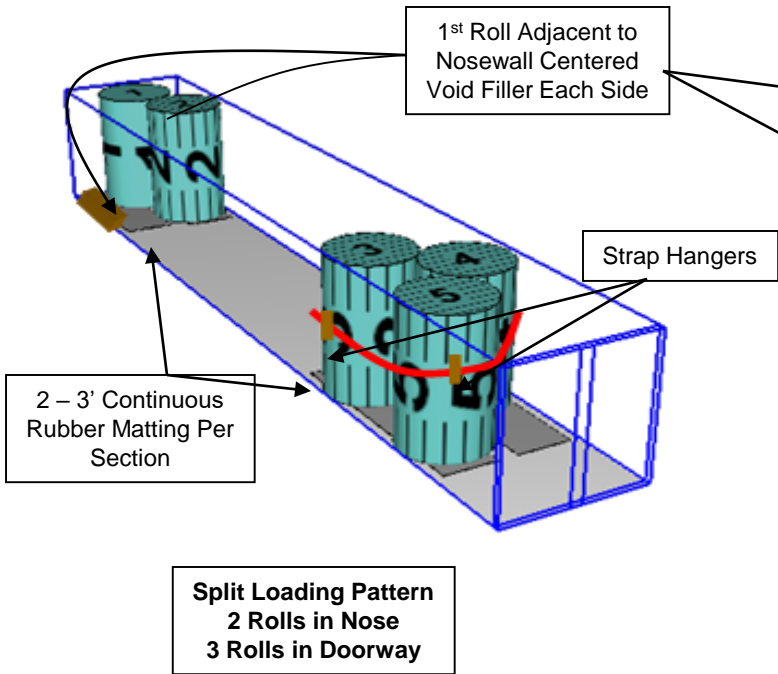
The rear section consists of three rolls. Prior to loading the rolls, tape an approved polyester or equivalent poly strap to the container sidewalls for unitizing the rear section. The strap must be level and positioned 18” to 24” from the top of the roll. Lay rubber matting in place and load the rear section. Place roll 3 against the left sidewall and load the remaining two rolls tightly lengthwise alternating sidewalls. Tighten unitizing strap and secure in place with fiberboard strap hangers or looped cord straps taped to several rolls.

Rubber Mat Requirements

The rubber matting must be a minimum of 3’ wide and extend a minimum of 6” beyond the rolls at each end of each mat except at the nosewall. As an alternative, 4’ wide matting may be utilized instead of the 3’ mat. The lengths will remain the same.

The following AAR approved rubber matting may be used with this loading method.

- TransMat 7513 [3mm (0.125”) thick]
- TransMat 6900 [3mm (0.125”) thick]
- Rubber Restraint Mat BC548 [3mm (0.125”) thick]
- Load Grip 5 [2mm (0.080”) thick]
- Load Lock [3mm (0.125”) thick]
- Brown Bear – Friction Mat 101 [2mm (0.080”) thick] or {3mm (0.125”) thick}



Rubber Matting



Fiberboard Filler



Poly Strapping

5 Floor Spots – Split Loading Plan
58” Diameter x 72” to 98” Width Rolls – Average Roll Weight –8,000 lbs
Roll Weights May Vary – Load Not To Exceed 45,000 LBS
2 Rolls in Nose – 3 Rolls in Rear Section

Nose Section First Roll Centered With Dunnage Each Side
Each Section Stowed in 1 -1 Offset Pattern on Top of 2 – 3’ x 3MM Rubber Mats
Doorway Section Unitized with Caristrap or 1-1/4” Equivalent Poly Strapping
Secured With Strap Hangers or Tape
Rubber Mat Must Extend 12” Beyond Rolls - Minimum 3’ Void Between Doors & Rolls

California 40’ Bridge Law – Loading Pattern Based on 456” Wheelbase

Roll Paper –58” Diameter - 72” to 98” Width – Split Loading Pattern

6 Floor Spots - Load Not to Exceed 45,000 LBS

This method is for 58” diameter roll paper or pulpboard loaded on end in a 1-1 offset pattern in a container for intermodal service. Plan the load to equalize the weight on each side of the container. A balanced load is required for the stability and success of this loading pattern.

The load is divided into two sections, three rolls each section. Place two 3’ rubber mats 12” apart (side-by-side) on the floor at the nose of the container, 6” longer than length of rolls. **Rubber matting must be one continuous length.** The first roll is placed tightly against the nosewall and left sidewall. Place the second roll tightly lengthwise against first roll and right sidewall, third roll along left sidewall (as illustrated in diagram).

A minimum of 3 feet of void is required between the cargo and the container doors. Position the rear section to obtain the proper weight distribution and maintain the 3’ void at the rear of the container.

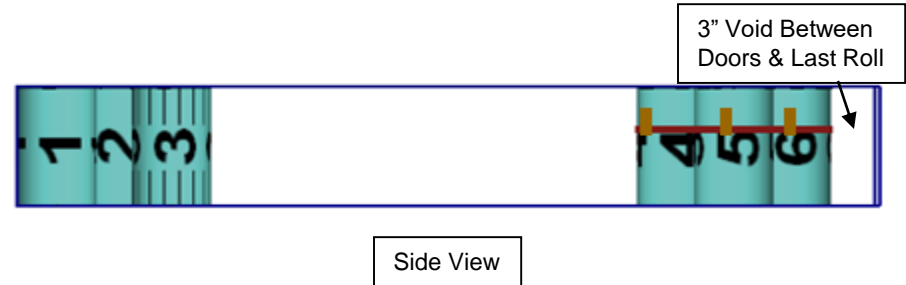
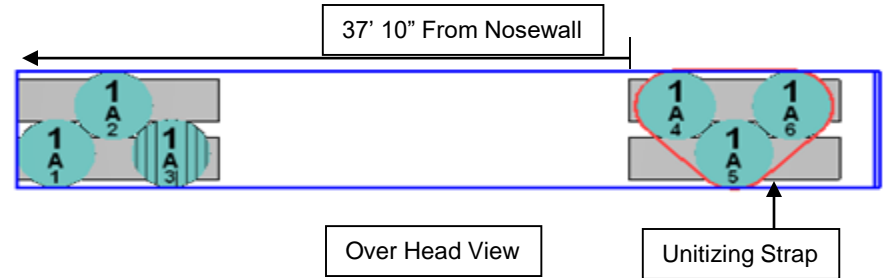
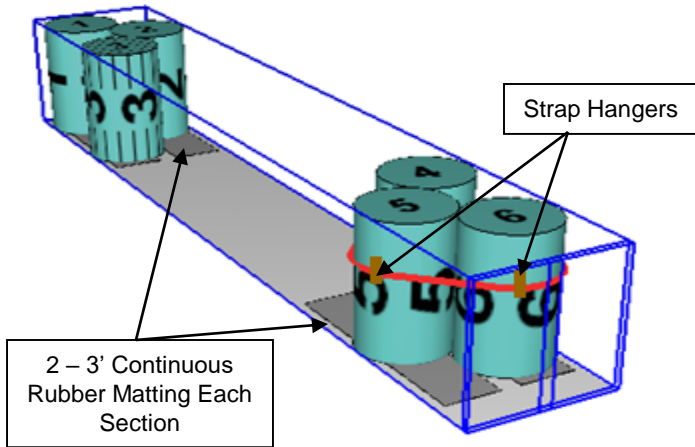
The rear section consists of three rolls. Prior to loading the rolls, tape an approved polyester or equivalent poly strap to the container sidewalls for unitizing the rear section. The strap must be level and positioned 18” to 24” from the top of the roll. Lay rubber matting in place and load the rear section. Place roll 4 against the right sidewall and load the remaining two rolls tightly lengthwise alternating sidewalls. Tighten unitizing strap and secure in place with fiberboard strap hangers or looped cord straps taped to several rolls.

Rubber Mat Requirements

The rubber matting must be a minimum of 3’ wide and extend a minimum of 6” beyond the rolls at each end of each mat except at the nosewall. As an alternative, 4’ wide matting may be utilized instead of the 3’ mat. The lengths will remain the same.

The following AAR approved rubber matting may be used with this loading method.

- TransMat 7513 [3mm (0.125”) thick]
- TransMat 6900 [3mm (0.125”) thick]
- Rubber Restraint Mat BC548 [3mm (0.125”) thick]
- Load Grip 5 [2mm (0.080”) thick]
- Load Lock [3mm (0.125”) thick]
- Brown Bear – Friction Mat 101 [2mm (0.080”) thick] or {3mm (0.125”) thick]



6 Floor Spots – Split Loading Plan

58" Diameter x 72" to 98" Width Rolls – Average Roll Weight - 7,500 lbs
Roll Weights May Vary – Load Not To Exceed 45,000 LBS

Each Section Stowed in 1 -1 Offset Pattern on Top of 2 – 3' x 3MM Rubber Mats
Doorway Section Unitized with Caristrap or 1-1/4" Equivalent Poly Strapping
Secured With Strap Hangers or Tape
Rear Section Loaded 37' 10" from Nosewall
Rubber Mat Must Extend 12" Beyond Rolls
Minimum 3' Void Between Doors & Rolls



Rubber Matting



Poly Strapping

California 40' Bridge Law – Loading Pattern Based on 456" Wheelbase

Roll Paper –58” Diameter - 72” to 98” Width – Split Loading Pattern

7 Floor Spots - Load Not to Exceed 45,000 LBS

This method is for 58” diameter roll paper or pulpboard loaded on end in a 1-1 offset pattern in a container for intermodal service. **Plan the load to equalize the weight on each side of the container.** A balanced load is required for the stability and success of this loading pattern.

The load is divided into two sections; three rolls in the front section, and four rolls in the doorway section. Place two 3’ rubber mats 12” apart (side-by-side) on the floor at the nose of the container, 6” longer than length of rolls. **Rubber matting must be one continuous length.** The first roll is centered against the nosewall with 3” x (void width) x 48” fiberboard dunnage filling the lateral void on each side of the roll. Place the second roll tightly lengthwise against first roll and right sidewall, third roll along left sidewall (as illustrated in diagram).

A minimum of 3 feet of void is required between the cargo and the container doors. Position the rear section to obtain the proper weight distribution and maintain the 3’ void at the rear of the container.

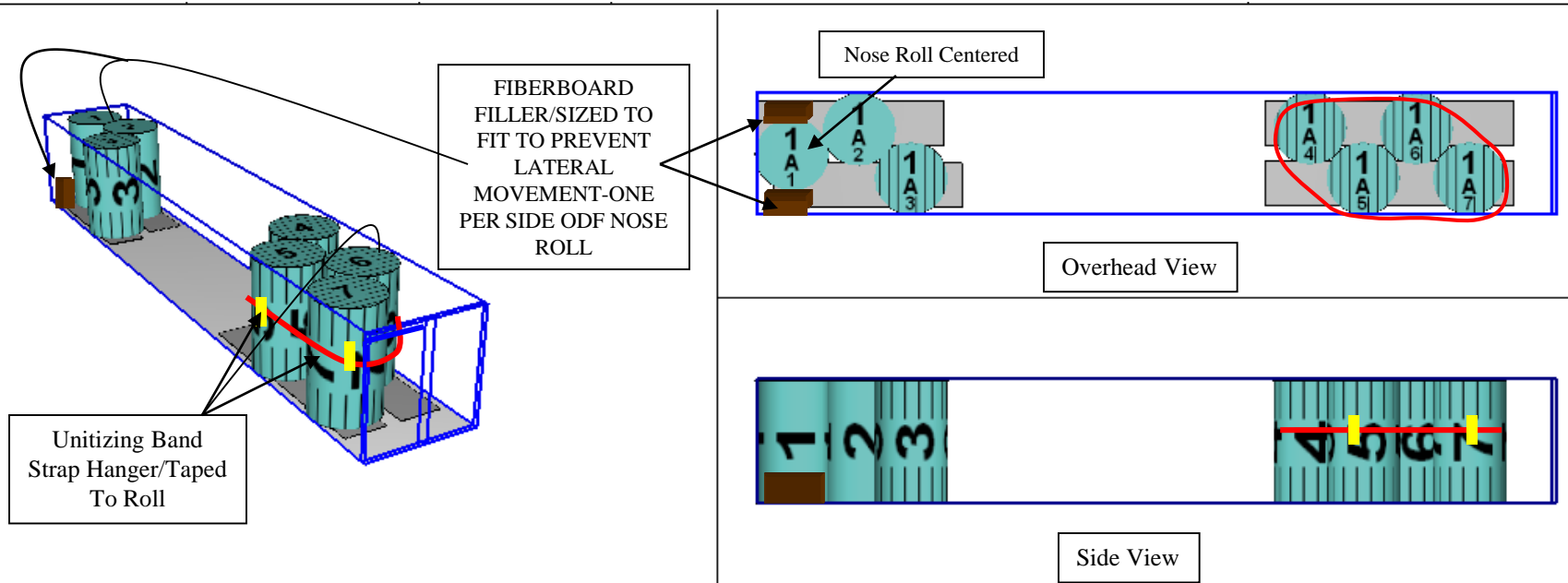
The rear section consists of four rolls. Prior to loading the rolls, tape an approved polyester or equivalent poly strap to the container sidewalls for unitizing the rear section. The strap must be level and positioned 18” to 24” from the top of the roll. Lay rubber matting in place and load the rear section. Place roll 4 against the right sidewall and load the remaining three rolls tightly lengthwise alternating sidewalls. Tighten unitizing strap and secure in place with fiberboard strap hangers or looped cord straps taped to several rolls.

Rubber Mat Requirements

The rubber matting must be a minimum of 3’ wide and extend a minimum of 6” beyond the rolls at each end of each mat except at the nosewall. As an alternative, 4’ wide matting may be utilized instead of the 3’ mat. The lengths will remain the same.

The following AAR approved rubber matting may be used with this loading method.

- TransMat 7513 [3mm (0.125”) thick]
- TransMat 6900 [3mm (0.125”) thick]
- Rubber Restraint Mat BC548 [3mm (0.125”) thick]
- Load Grip 5 [2mm (0.080”) thick]
- Load Lock [3mm (0.125”) thick]
- Brown Bear – Friction Mat 101 [2mm (0.080”) thick] or {3mm (0.125”) thick}



Rubber Matting



Fiberboard Filler

7 Floor Spots – Split Loading Plan
58” Diameter x 72” to 98” Width Rolls – Average Roll Weight – 6,300 lbs
Roll Weights May Vary – Load Not To Exceed 45,000 LBS

Nose Section First Roll Centered With Dunnage Each Side
Each Section Stowed in 1 -1 Offset Pattern on Top of 2 – 3’ x 3MM Rubber Mats
Doorway Section Unitized with Caristrap or 1-1/4” Equivalent Poly Strapping
Secured With Strap Hangers or Tape
Rear Section Load 31’ From Nosewall
Rubber Mat Must Extend 12” Beyond Rolls - Minimum 3’ Void Between Doors & Rolls

California 40’ Bridge Law – Loading Pattern Based on 456” Wheelbase



Poly Strapping

Roll Paper –58” Diameter - 72” to 98” Width – Split Loading Pattern

8 Floor Spots - Load Not to Exceed 45,000 LBS

This method is for 58” diameter roll paper or pulpboard loaded on end in a 1-1 offset pattern in a container for intermodal service. **Plan the load to equalize the weight on each side of the container.** A balanced load is required for the stability and success of this loading pattern.

The load is divided into two sections, four rolls each section. Place two 3’ rubber mats 12” apart (side-by-side) on the floor at the nose of the container, 6” longer than length of rolls. **Rubber matting must be one continuous length.** The first roll is placed tightly against the nosewall and left sidewall. Place the second roll tightly lengthwise against first roll and right sidewall, third and fourth roll loaded tightly lengthwise alternating sidewalls as illustrated.

A minimum of 3 feet of void is required between the cargo and the container doors. Position the rear section to obtain the proper weight distribution and maintain the 3’ void at the rear of the container.

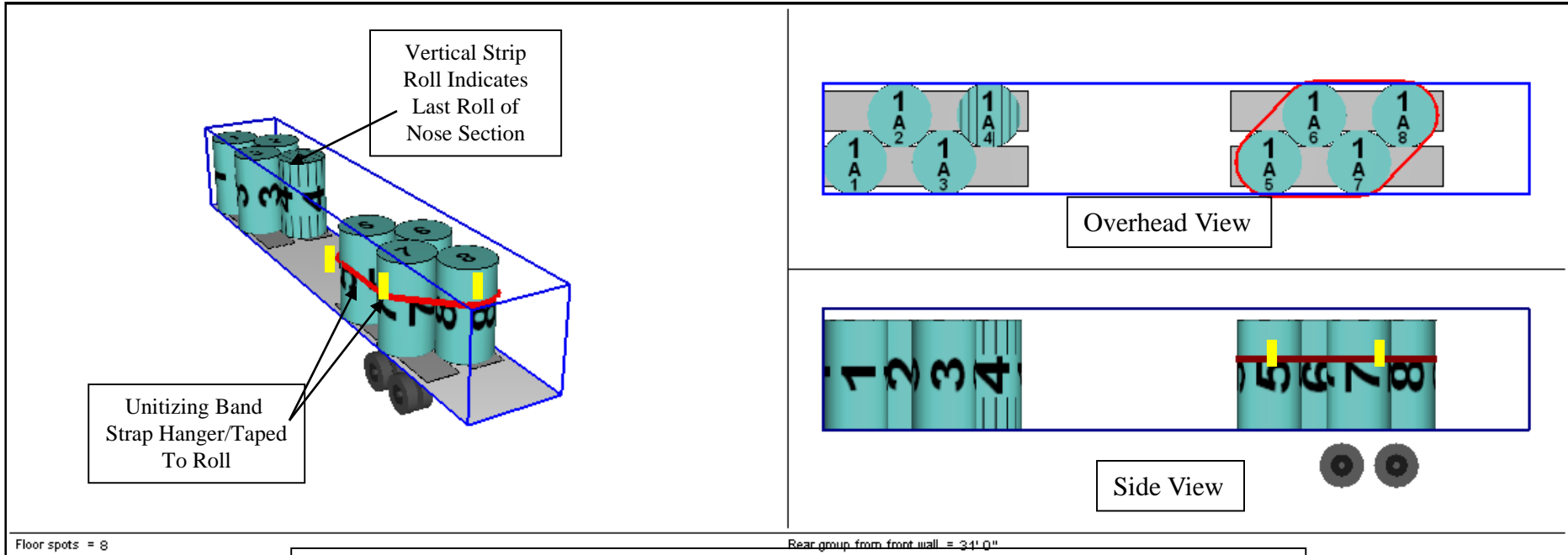
The rear section consists of four rolls. Prior to loading the rolls, tape an approved polyester or equivalent poly strap to the container sidewalls for unitizing the rear section. The strap must be level and positioned 18” to 24” from the top of the roll. Lay rubber matting in place and load the rear section. Place roll 5 against the left sidewall and load the remaining three rolls tightly lengthwise alternating sidewalls. Tighten unitizing strap and secure in place with fiberboard strap hangers or looped cord straps taped to several rolls.

Rubber Mat Requirements

The rubber matting must be a minimum of 3’ wide and extend a minimum of 6” beyond the rolls at each end of each mat except at the nosewall. As an alternative, 4’ wide matting may be utilized instead of the 3’ mat. The lengths will remain the same.

The following AAR approved rubber matting may be used with this loading method.

- TransMat 7513 [3mm (0.125”) thick]
- TransMat 6900 [3mm (0.125”) thick]
- Rubber Restraint Mat BC548 [3mm (0.125”) thick]
- Load Grip 5 [2mm (0.080”) thick]
- Load Lock [3mm (0.125”) thick]
- Brown Bear – Friction Mat 101 [2mm (0.080”) thick] or {3mm (0.125”) thick}



8 Floor Spots – Split Loading Plan
58" Diameter x 72" to 98" Width Rolls – Average Roll Weight - 5,500 lbs
Roll Weights May Vary – Load Not To Exceed 45,000 LBS

Each Section Stowed in 1 -1 Offset Pattern on Top of 2 – 3' x 3MM Rubber Mats
Doorway Section Unitized with Caristrap or 1-1/4" Equivalent Poly Strapping
Secured With Strap Hangers or Tape
Rear Section Load 31' From Nosewall
Rubber Mat Must Extend 12" Beyond Rolls
Minimum 3' Void Between Doors & Rolls



Rubber Matting



Poly Strapping

California 40' Bridge Law – Loading Pattern Based on 456" Wheelbase

Roll Paper –58” Diameter - 72” to 98” Width – Split Loading Pattern

9 Floor Spots - Load Not to Exceed 45,000 LBS

This method is for 58” diameter roll paper or pulpboard loaded on end in a 1-1 offset pattern in a container for intermodal service. **Plan the load to equalize the weight on each side of the container.** A balanced load is required for the stability and success of this loading pattern.

The load is divided into two sections; four rolls in the front section, and five rolls in the doorway section. Place two 3’ rubber mats 12” apart (side-by-side) on the floor at the nose of the container, 6” longer than length of rolls. **Rubber matting must be one continuous length.** The first roll is centered against the nosewall with 3” x (void width) x 48” fiberboard dunnage filling the lateral void on each side of the roll. Place the second roll tightly lengthwise against first roll and right sidewall, third and fourth roll loaded tightly lengthwise alternating sidewalls as illustrated.

A minimum of 3 feet of void is required between the cargo and the container doors. Position the rear section to obtain the proper weight distribution and maintain the 3’ void at the rear of the container.

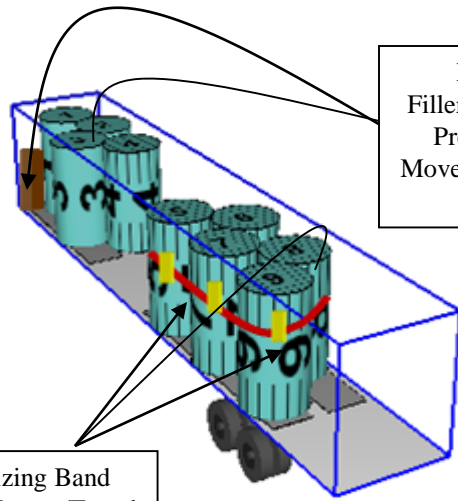
The rear section consists of five rolls. Prior to loading the rolls, tape an approved polyester or equivalent poly strap to the container sidewalls for unitizing the rear section. The strap must be level and positioned 18” to 24” from the top of the roll. Lay rubber matting in place and load the rear section. Place roll 5 against the left sidewall and load the remaining four rolls tightly lengthwise alternating sidewalls. Tighten unitizing strap and secure in place with fiberboard strap hangers or looped cord straps taped to several rolls.

Rubber Mat Requirements

The rubber matting must be a minimum of 3’ wide and extend a minimum of 6” beyond the rolls at each end of each mat except at the nosewall. As an alternative, 4’ wide matting may be utilized instead of the 3’ mat. The lengths will remain the same.

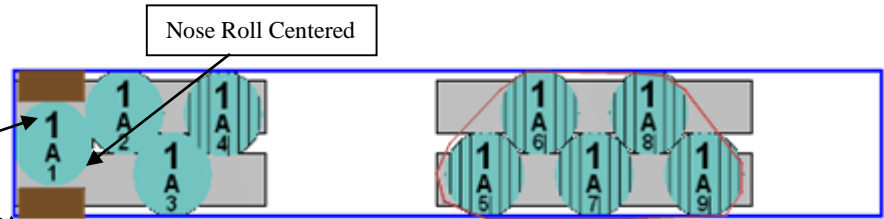
The following AAR approved rubber matting may be used with this loading method.

- TransMat 7513 [3mm (0.125”) thick]
- TransMat 6900 [3mm (0.125”) thick]
- Rubber Restraint Mat BC548 [3mm (0.125”) thick]
- Load Grip 5 [2mm (0.080”) thick]
- Load Lock [3mm (0.125”) thick]
- Brown Bear – Friction Mat 101 [2mm (0.080”) thick] or {3mm (0.125”) thick]



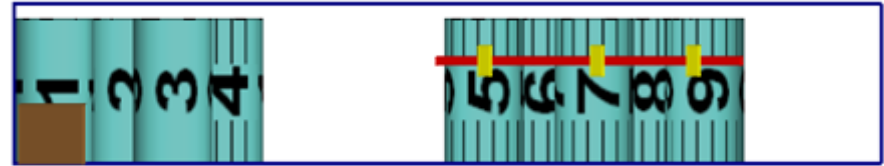
Fiberboard Filler/Sized to Fit to Prevent Lateral Movement – One Per Side

Unitizing Band Strap Hanger/Taped To Roll



Nose Roll Centered

Overhead View



Side View



Rubber Matting



Fiberboard Filler

9 Floor Spots – Split Loading Plan
58” Diameter x 72” to 98” Width Rolls – Average Roll Weight – 4,800 lbs
Roll Weights May Vary – Load Not To Exceed 45,000 LBS

Nose Section First Roll Centered With Dunnage Each Side
 Each Section Stowed in 1 -1 Offset Pattern on Top of 2 – 3’ x 3MM Rubber Mats
 Doorway Section Unitized with Caristrap or 1-1/4” Equivalent Poly Strapping
 Secured With Strap Hangers or Tape
 Rear Section Load 31’ From Nosewall
Rubber Mat Must Extend 12” Beyond Rolls - Minimum 3’ Void Between Doors & Rolls

California 40’ Bridge Law – Loading Pattern Based on 456” Wheelbase



Poly Strapping

Roll Paper –58” Diameter - 72” to 98” Width – Split Loading Pattern

10 Floor Spots - Load Not to Exceed 45,000 LBS

This method is for 58” diameter roll paper or pulpboard loaded on end in a 1-1 offset pattern in a container for intermodal service. **Plan the load to equalize the weight on each side of the container.** A balanced load is required for the stability and success of this loading pattern.

The load is divided into two sections, five rolls each section. Place two 3’ rubber mats 12” apart (side-by-side) on the floor at the nose of the container, 6” longer than length of rolls. **Rubber matting must be one continuous length.** The first roll is placed tightly against the nosewall and left sidewall. Place the second roll tightly lengthwise against first roll and right sidewall, third, fourth, and fifth roll along alternating sidewalls as illustrated.

A minimum of 3 feet of void is required between the cargo and the container doors. Position the rear section to obtain the proper weight distribution and maintain the 3’ void at the rear of the container.

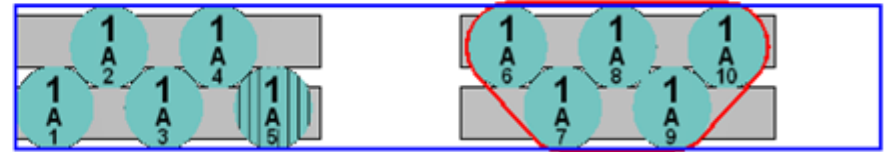
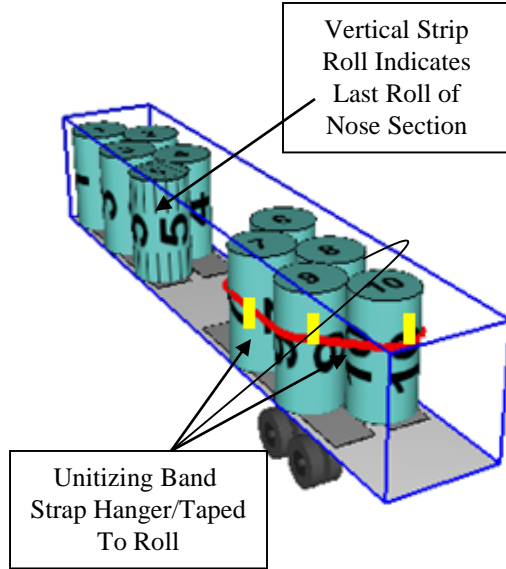
The rear section consists of five rolls. Prior to loading the rolls, tape an approved polyester or equivalent poly strap to the container sidewalls for unitizing the rear section. The strap must be level and positioned 18” to 24” from the top of the roll. Lay rubber matting in place and load the rear section. Place roll 6 against the right sidewall and load the remaining four rolls tightly lengthwise alternating sidewalls. Tighten unitizing strap and secure in place with fiberboard strap hangers or looped cord straps taped to several rolls.

Rubber Mat Requirements

The rubber matting must be a minimum of 3’ wide and extend a minimum of 6” beyond the rolls at each end of each mat except at the nosewall. As an alternative, 4’ wide matting may be utilized instead of the 3’ mat. The lengths will remain the same.

The following AAR approved rubber matting may be used with this loading method.

- TransMat 7513 [3mm (0.125”) thick]
- TransMat 6900 [3mm (0.125”) thick]
- Rubber Restraint Mat BC548 [3mm (0.125”) thick]
- Load Grip 5 [2mm (0.080”) thick]
- Load Lock [3mm (0.125”) thick]
- Brown Bear – Friction Mat 101 [2mm (0.080”) thick] or {3mm (0.125”) thick]



Overhead View



Side View

10 Floor Spots – Split Loading Plan
58” Diameter x 72” to 98” Width Rolls – Average Roll Weight – 4,400 lbs
Roll Weights May Vary – Load Not To Exceed 45,000 LBS

Each Section Stowed in 1 -1 Offset Pattern on Top of 2 – 3’ x 3MM Rubber Mats
 Doorway Section Unitized with Caristrap or 1-1/4” Equivalent Poly Strapping
 Secured With Strap Hangers or Tape
 Rear Section Loaded 27’ 8” from Nosewall
 Rubber Mat Must Extend 12” Beyond Rolls
 Minimum 3’ Void Between Doors & Rolls



Rubber Matting



Poly Strapping

California 40’ Bridge Law – Loading Pattern Based on 456” Wheelbase

Roll Paper –58” Diameter - 72” to 98” Width – Split Loading Pattern

11 Floor Spots - Load Not to Exceed 45,000 LBS

This method is for 58” diameter roll paper or pulpboard loaded on end in a 1-1 offset pattern in a container for intermodal service. A balanced load is required for the stability and success of this loading pattern.

The load is loaded in one section starting at the nose and continuing to the rear of the container. **Rubber matting must be one continuous length**, place two 3’ wide mats 12” apart (side-by-side) in the nose and doorway. The first two rolls from the nose and the last five rolls in the doorway must be loaded on rubber matting. The first roll is placed tightly against the nosewall and left sidewall. Place the second roll tightly lengthwise against first roll and right sidewall; load remaining rolls alternating sidewalls as illustrated in the diagram.

A minimum of 3 feet of void is required between the cargo and the container doors.

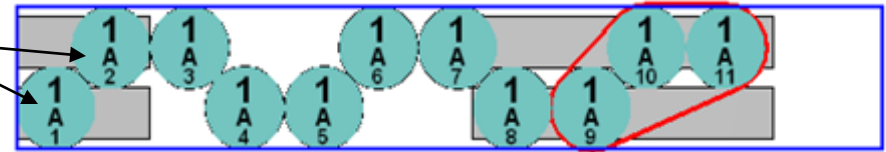
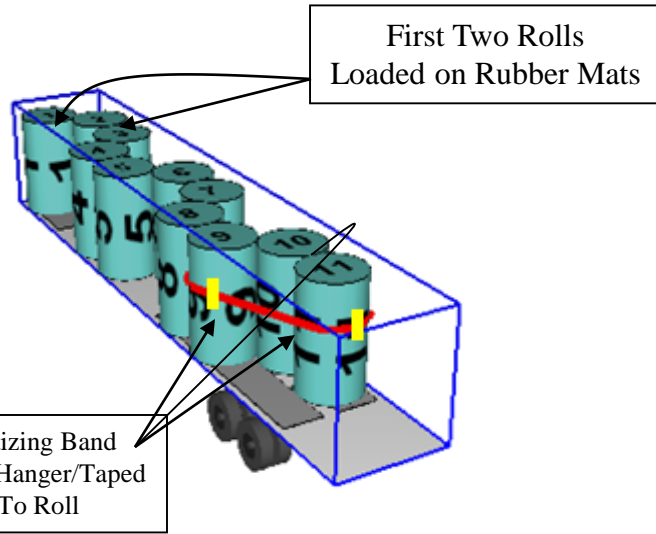
The last three rolls must be unitized. Prior to loading the last three rolls, tape an approved polyester or equivalent poly strap to the container sidewalls for unitizing the rear section. The strap must be level and positioned 18” to 24” from the top of the roll. Tighten unitizing strap and secure in place with fiberboard strap hangers or looped cord straps taped to several rolls.

Rubber Mat Requirements

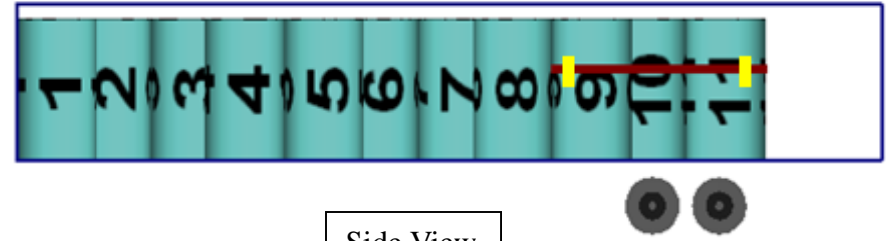
The rubber matting must be a minimum of 3’ wide and extend a minimum of 6” beyond the rolls at each end of each mat except at the nosewall. As an alternative, 4’ wide matting may be utilized instead of the 3’ mat. The lengths will remain the same.

The following AAR approved rubber matting may be used with this loading method.

- TransMat 7513 [3mm (0.125”) thick]
- TransMat 6900 [3mm (0.125”) thick]
- Rubber Restraint Mat BC548 [3mm (0.125”) thick]
- Load Grip 5 [2mm (0.080”) thick]
- Load Lock [3mm (0.125”) thick]
- Brown Bear – Friction Mat 101 [2mm (0.080”) thick] or {3mm (0.125”) thick}



Overhead View



Side View

11 Floor Spots
58" Diameter x 72" to 98" Width Rolls – Average Roll Weight – 4,000 lbs
Roll Weights May Vary – Load Not To Exceed 45,000 LBS

Rolls Stowed In The Above Offset Pattern on Top of 2 – 3' x 3MM Rubber Mats
First Two Rolls Loaded on Rubber Matting
Last Four Rolls Loaded on Rubber Matting
Last Three Rolls in Doorway Unitized with Caristrap or 1-1/4" Equivalent Poly Strapping
Secured With Strap Hangers or Tape
Rubber Mat Must Extend 12" Beyond Last Roll
Minimum 3' Void Between Doors & Rolls

California 40' Bridge Law – Loading Pattern Based on 456" Wheelbase



Rubber Matting



Poly Strapping

Roll Paper –58” Diameter - 72” to 98” Width – Split Loading Pattern

12 Floor Spots - Load Not to Exceed 45,000 LBS

This method is for 58” diameter roll paper or pulpboard loaded on end in a 1-1 offset pattern in a container for intermodal service. A balanced load is required for the stability and success of this loading pattern.

The load is loaded in one section starting at the nose and continuing to the rear of the container. **Rubber matting must be one continuous length**, place two 3’ wide mats 12” apart (side-by-side) in the nose and doorway. The first three rolls from the nose and the last five rolls in the doorway must be loaded on rubber matting. The first roll is placed tightly against the nosewall and left sidewall. Place the second roll tightly lengthwise against first roll and right sidewall, load remaining rolls alternating sidewalls as illustrated in the diagram.

A minimum of 3 feet of void is required between the cargo and the container doors.

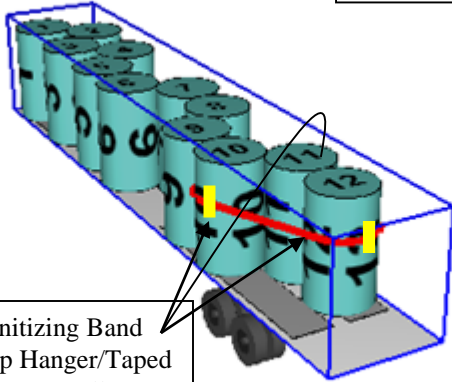
The last three rolls must be unitized. Prior to loading the last three rolls, tape an approved polyester or equivalent poly strap to the container sidewalls for unitizing the rear section. The strap must be level and positioned 18” to 24” from the top of the roll. Tighten unitizing strap and secure in place with fiberboard strap hangers or looped cord straps taped to several rolls.

Rubber Mat Requirements

The rubber matting must be a minimum of 3’ wide and extend a minimum of 6” beyond the rolls at each end of each mat except at the nosewall. As an alternative, 4’ wide matting may be utilized instead of the 3’ mat. The lengths will remain the same.

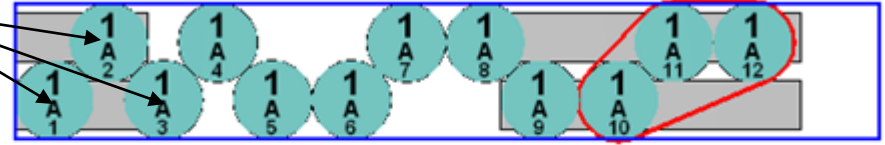
The following AAR approved rubber matting may be used with this loading method.

- TransMat 7513 [3mm (0.125”) thick]
- TransMat 6900 [3mm (0.125”) thick]
- Rubber Restraint Mat BC548 [3mm (0.125”) thick]
- Load Grip 5 [2mm (0.080”) thick]
- Load Lock [3mm (0.125”) thick]
- Brown Bear – Friction Mat 101 [2mm (0.080”) thick] or {3mm (0.125”) thick}

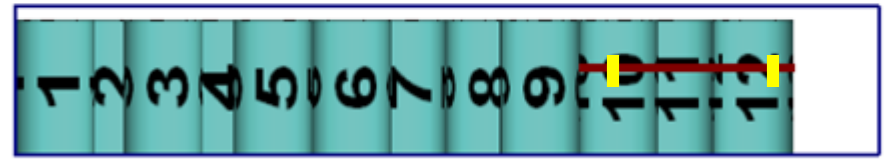


Unitizing Band
Strap Hanger/Taped
To Roll

First Three Rolls
Loaded on Rubber Mats



Overhead View



Side View

12 Floor Spots

58" Diameter x 72" to 98" Width Rolls – Average Roll Weight – 3,700 lbs
Roll Weights May Vary – Load Not To Exceed 45,000 LBS

Rolls Stowed In The Above Offset Pattern on Top of 2 – 3' x 3MM Rubber Mats

First Three Rolls Loaded on Rubber Matting

Last Five Rolls Loaded on Rubber Matting

Last Three Rolls in Doorway Unitized with Caristrap or 1-1/4" Equivalent Poly Strapping

Secured With Strap Hangers or Tape

Rubber Mat Must Extend 12" Beyond Last Roll

Minimum 3' Void Between Doors & Rolls

California 40' Bridge Law – Loading Pattern Based on 456" Wheelbase



Rubber Matting



Poly Strapping

Palletized Flat Stock Paper (2 - 2 Offset Pattern) – Braced with D.I.D. Bags

Palletized case goods unitized with either shrink-wrap or stretch-wrap in accordance with the manufacturer's specifications. D.I.D. bags must be a minimum of 48" x 96" (Level 1). Two D.I.D. bags are utilized for load securement; the first is placed in the center of the load and the second at the rear of the load.

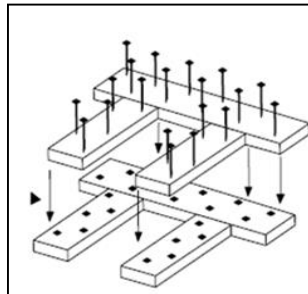
Pallets are loaded in a 2-2 offset pattern. The pallet's 48" dimension is loaded laterally in 102" width equipment and the 40" dimension is loaded laterally in 96" width equipment. Note: Loaded laterally = perpendicular to equipment sidewalls. The load plan should minimize lateral void space. Except at D.I.D. bag locations (102" width equipment), it's permissible to load the 48" dimension longitudinal in order to "stretch out the load" and maintain proper OTR axle weights.

Disposable Inflatable Dunnage (D.I.D.) Bag

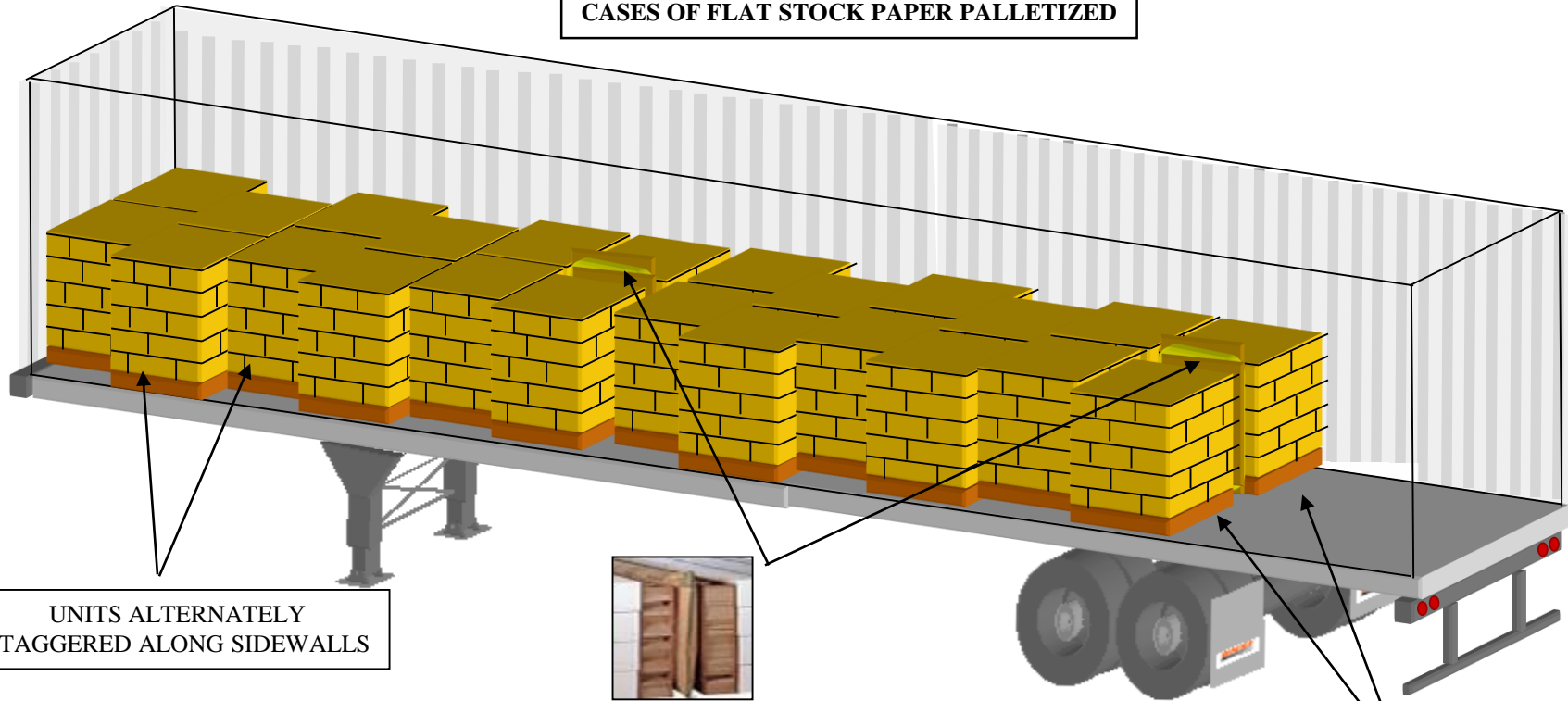
The D.I.D. bag must not be used in a void space in excess of 12" wide. If the void space exceeds 12" width, additional full size void fillers must be placed along side the D.I.D. bag. After inflation, the D.I.D. bag should be located approximately 4" above the equipment floor. The D.I.D. bag must be adequately buffered to prevent contact with sharp or rough edges that may puncture the bag. Maximum D.I.D. bag inflation of 2 PSI; leave approximately 24" space between the rear of the load and the equipment doors.

Alternative Securement: Wood Floor Blocking/Bracing

The rear of the load is secured with 2"x6" wood floor blocking. At rear of load, the wood floor blocking runs the entire width of the rear pallet and is reinforced with three 2" x 6" x 18" back-up cleats. The wood floor blocking is secured with 16d nails that are spaced four-inches apart in a staggered pattern. A staggered pattern prevents the nails from splitting the wood.



CASES OF FLAT STOCK PAPER PALLETIZED



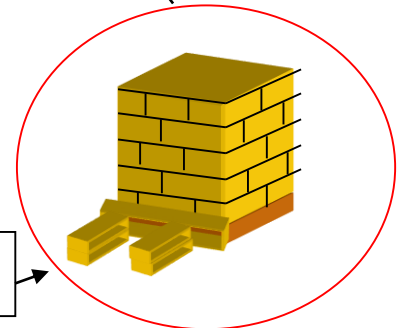
UNITS ALTERNATELY
STAGGERED ALONG SIDEWALLS



48"X48"X 2 PLY DID BAGS
BETWEEN FILLER MATERIAL

DID BAGS MUST NOT BE USED IN VOID SPACES IN EXCESS OF 12", MUST NOT CONTACT FLOOR OF TRAILER OR PALLET AFTER INFLATION, MUST BE ADEQUATELY BUFFERED WHEN IN CONTACT WITH ROUGH SURFACES, AND SHOULD BE INFLATED BETWEEN 1.5 & 2 PSI.

**NOTE: LAMINATED FLOOR BRACING MAY
BE UTILIZED IN PLACE OF AIRBAGS.**



SCRAP METAL

(Loose, Packaged, Baled)



Scrap metal is defined as a “restricted commodity” on BNSF Railway. Please review BNSF Intermodal Rules & Policies Guide Item 43 for details.

Scrap Metal (Loose or Packaged) – Braced with Bull Boards at Rear of Load

The weight of the scrap metal product must be distributed evenly both lengthwise and laterally in the trailer or container. Lading weight must be distributed evenly over the entire surface area of the equipment floor, with no more than 25,000 lbs. in any ten (10) linear feet or 2,500 lbs. per linear foot, regardless of commodity.

It is the shipper's responsibility to prevent leakage (oil, grease, water, anti-freeze, etc.) from the scrap metal product. All liquids should be drained or removed from the cargo. If residual liquids cannot be eliminated from the cargo, equipment floor liners or absorbent materials are alternatives to prevent leakage through the equipment floor.

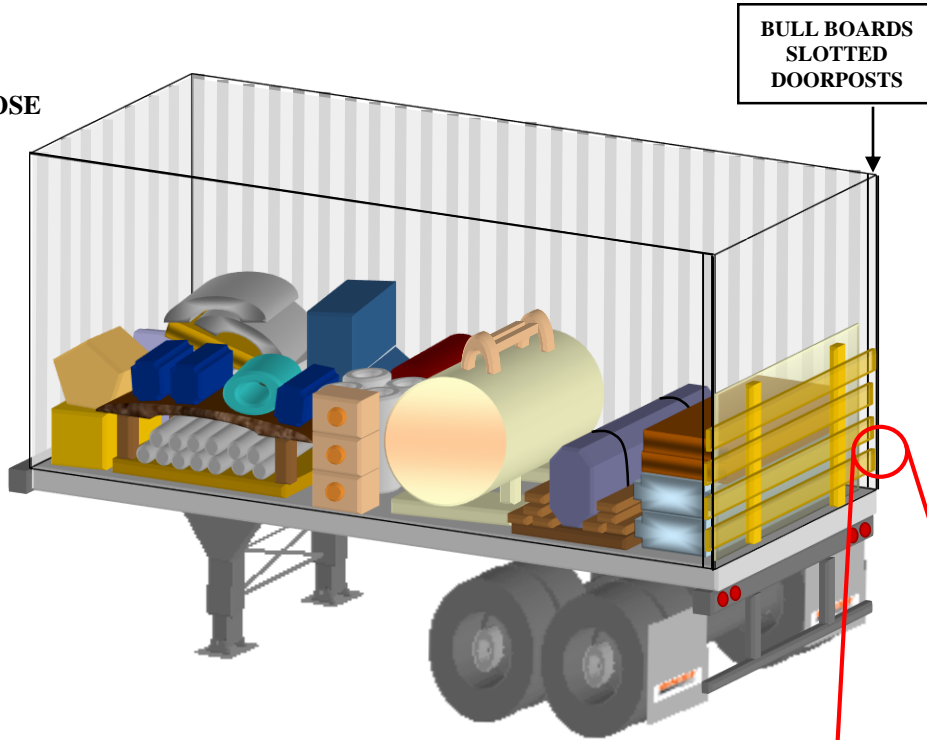
Under no circumstances can a cylindrical-shaped scrap metal object that weighs more than 3,500 lbs. be loaded directly on the equipment floor. This type of object must be secured on bearing pieces, pallets or skids that properly distribute the concentrated weight over a greater surface area of the equipment floor. BNSF Load and Ride Solutions must approve the loading, blocking and bracing of cylindrical-shaped scrap metal objects that weigh more than 3,500 lbs. *prior to shipping*.

The rear of the load is secured with 2"x4" or 2"x6" bull boards. The bull boards may be inserted into the slotted door posts or corrugated sidewalls of the container equipment. The bull boards are nailed to vertical 2"x4" stabilizers in order to prevent displacement. Plywood buffer protection may be placed between the lading and the bull boards.

Bull Boards: The size and number of bull boards utilized will be determined by the net cargo weight that is being restrained. Based upon the "load restraining capacity" of 2"x4" and 2"x6" bull boards summarized on the loading diagram, a 40,000 lb. load would require securement with five 2"x6" bull boards.

SCRAP METAL

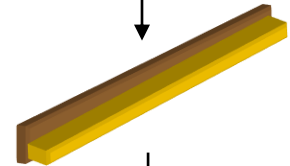
NOSE



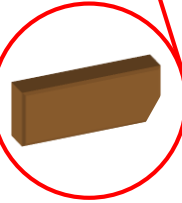
BULL BOARDS
SLOTTED
DOORPOSTS

LOAD RESTRAINING CAPACITY	
RESTRAINT DEVICE	CAPACITY
2" X 4" BULL BOARD	5,600 LBS
2" X 6" BULL BOARD	8,000 LBS
2" X 4" "T" BRACE	7,000 LBS

"T" BRACE METHOD OF REINFORCING BULL BOARD. SHOWN BACKWARDS FOR CLARITY.



PLYWOOD BUFFER MATERIAL PLACED BETWEEN LADING & BULL BOARDS HELP EVENLY DISTRIBUTE LADING FORCES



MITER CORNERS TO SIMPLIFY DROPPING BULL BOARDS IN PLACE

SCRAP METAL LOAD SECUREMENT

- 1.) Bull Boards Secured into Slotted Doorposts at Rear of Load. Plywood Buffer Protection placed between Lading and Bull Boards.
- 2.) Under **No Circumstances** can a Cylindrical-Shaped Object that Weighs more than 3,500 Lbs. be Loaded Directly on Floor of Equipment. The Scrap Metal Object must be Secured on Pallet, Skid, Bearing Pieces, Etc., that Properly Distribute Concentrated Weight.

Scrap Metal Bales – Braced with Bull Boards at Rear of Load

Scrap metal bales are loaded in an offset pattern, generally one/two layers high, from nose to rear of container equipment.

The weight of the scrap metal bales must be distributed evenly both longitudinally and laterally in the trailer or container. cargo weight must be distributed evenly over the entire surface area of the equipment floor, with no more than 25,000 lbs. in any ten (10) linear feet or 2,500 lbs. per linear foot, regardless of commodity.

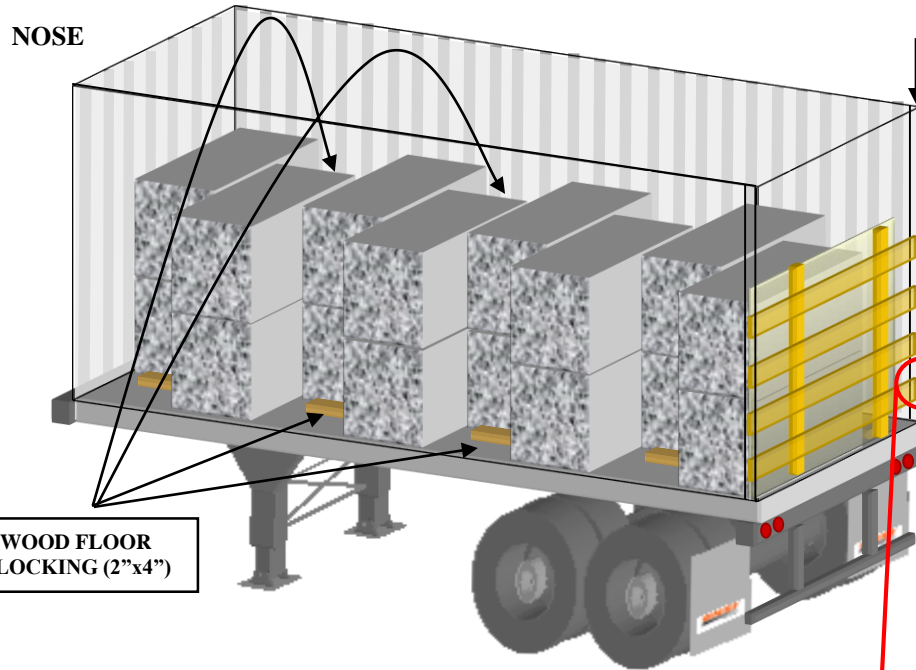
It is the shipper's responsibility to prevent leakage (oil, grease, water, anti-freeze, etc.) from the scrap metal product. All liquids should be drained or removed from the cargo. If residual liquids cannot be eliminated from the cargo, equipment floor liners or absorbent materials are alternatives to prevent leakage through the equipment floor.

Wood floor blocking is required to restrict lateral movement of cargo. Each stack of baled scrap metal is restrained with one 2"x4"x18" piece of lumber, which is secured to the equipment floor with four 16d nails placed in a staggered pattern. A staggered nail pattern prevents the nails from splitting the wood.

The rear of the load is secured with 2"x4" or 2"x6" bull boards in order to restrict longitudinal movement of cargo. The bull boards may be inserted into the slotted door posts or corrugated sidewalls of the container equipment. The bull boards are nailed to vertical 2"x4" stabilizers in order to prevent displacement. Plywood buffer protection may be placed between the cargo and the bull boards.

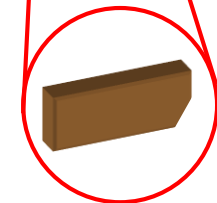
Bull Boards: The size and number of bull boards utilized will be determined by the net cargo weight that is being restrained. Based upon the "load restraining capacity" of 2"x4" and 2"x6" bull boards summarized on the loading diagram, a 40,000 lb. load would require securement with five 2"x6" bull boards.

SCRAP METAL BALES – WOOD FLOOR BLOCKING



WOOD FLOOR
BLOCKING (2"x4")

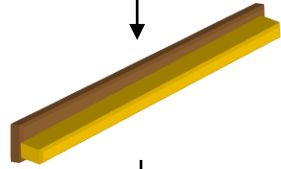
BULL BOARDS
SLOTTED
DOORPOSTS



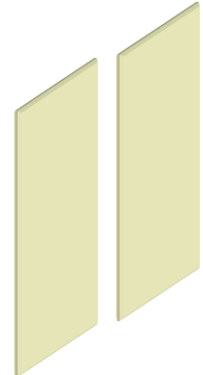
MITER CORNERS TO SIMPLIFY
DROPPING BULL BOARDS IN PLACE

LOAD RESTRAINING CAPACITY	
RESTRAINT DEVICE	CAPACITY
2" X 4" BULL BOARD	5,600 LBS
2" X 6" BULL BOARD	8,000 LBS
2" X 4" "T" BRACE	7,000 LBS

"T" BRACE METHOD OF REINFORCING
BULL BOARD. SHOWN BACKWARDS FOR
CLARITY.



PLYWOOD BUFFER MATERIAL PLACED
BETWEEN LADING & BULL BOARDS HELP
EVENLY DISTRIBUTE LADING FORCES



SCRAP METAL LOAD SECUREMENT

- 1.) Bales of Scrap Metal Loaded in Offset Pattern, Two Layers High, from Nose to Rear Doors of Container Equipment.
- 2.) Lateral Floor Blocking = 2"x4"x18." Floor Blocking Utilized for Each Stack of Two-High Bales, Secured with Minimum of 4 Nails (16d).
- 3.) Bull Boards Secured into Slotted Doorposts at Rear of Load. Plywood Buffer Protection placed between Bales & Bull Boards.

Scrap Metal Bales – Braced with Wood Floor Blocking at Rear of Load

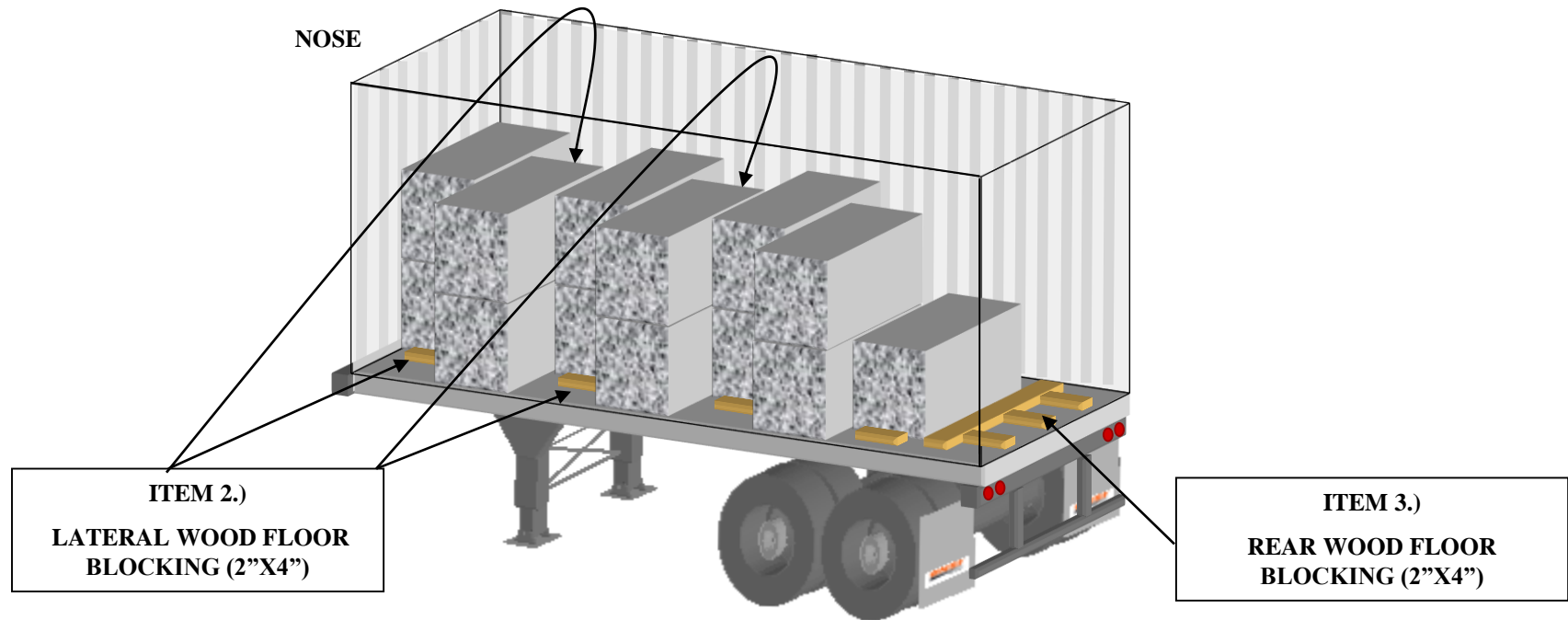
Scrap metal bales are loaded in an offset pattern, generally one/two layers high, from nose to rear of container equipment. The height of bales is reduced to one-layer at rear of load, in order to prevent top layer from shifting against rear doors.

The weight of the scrap metal bales must be distributed evenly both lengthwise and laterally in the trailer or container. Cargo weight must be distributed evenly over the entire surface area of the equipment floor, with no more than 25,000 lbs. in any ten (10) linear feet or 2,500 lbs. per linear foot, regardless of commodity.

It is the shipper's responsibility to prevent leakage (oil, grease, water, anti-freeze, etc.) from the scrap metal product. All liquids should be drained or removed from the cargo. If residual liquids cannot be eliminated from the cargo, equipment floor liners or absorbent are alternatives to prevent leakage through the equipment floor.

Wood Floor Blocking/Bracing

The rear of the load is secured with 2"x4" wood floor blocking in order to restrict longitudinal movement. At rear of load, the wood floor blocking runs the entire width of the equipment and is reinforced with three 2"x4"x18" back-up cleats. One side of each stack of multi-layered baled scrap metal is also secured with 2"x4"x18" wood floor blocking to restrict lateral movement. The rear single-high bale is laterally centered in the container and each side is secured with 2"x4"x18" wood floor blocking. All wood floor blocking is secured with 16d nails that are spaced four-six inches apart in a staggered pattern. A staggered nail pattern prevents the nails from splitting the wood.

SCRAP METAL BALES – WOOD FLOOR BLOCKING**SCRAP METAL LOAD SECUREMENT**

- 1.) Bales of Scrap Metal Loaded in Offset Pattern, Two Layers High (Except at Rear of Load).
- 2.) Floor Blocking (Lateral) = 2"x4"x18," Secured with Minimum of 4 Nails (16d). Lateral (Side) Floor Blocking Utilized for Each Stack of Two-High Bales (One Side). Lateral Floor Blocking also Utilized for Each Single High Bale at Rear of Load (Both Sides).
- 3.) Floor Blocking (Rear) = 2"x4"x8' with 2"x4"x18" Back-Up Cleats. Floor Blocking Secured with 16d Nails placed 4" apart in Staggered Pattern.

Scrap Metal (Bulk) – Braced with Bull Boards at Rear of Load

A “bulk” scrap metal shipment is defined as: *scrap metal product that covers the entire surface area of the equipment floor.* Cargo weight must be distributed evenly over the entire surface area of the equipment floor, with no more than 25,000 lbs. in any ten (10) linear feet or 2,500 lbs. per linear foot, regardless of commodity.

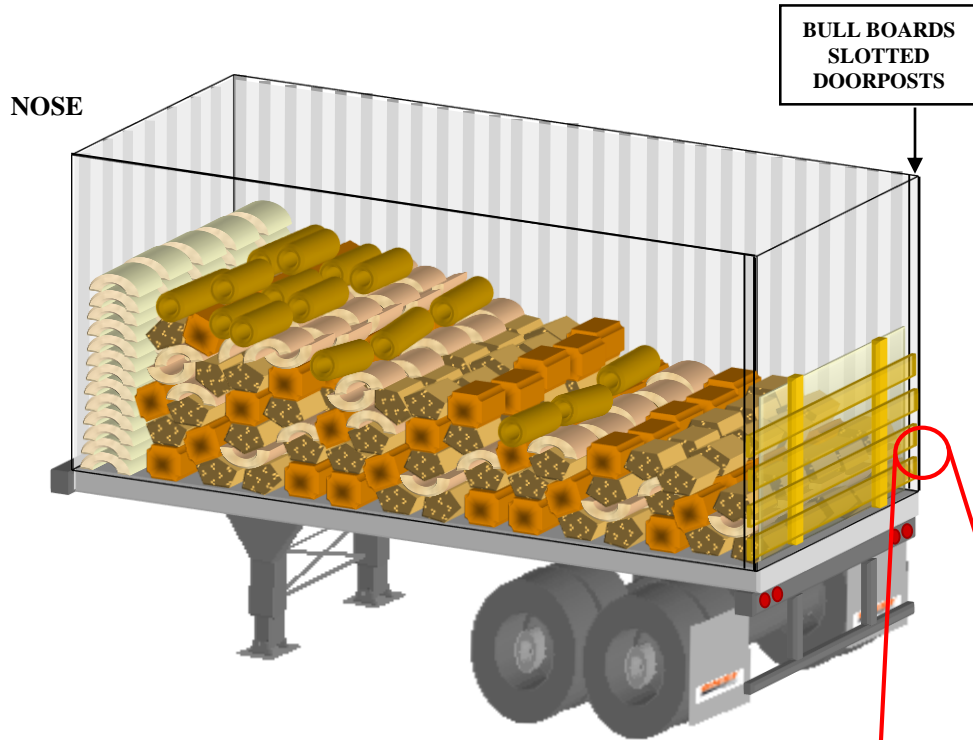
It is the shipper’s responsibility to prevent leakage (oil, grease, water, anti-freeze, etc.) from the scrap metal product. If practical and possible, all liquids should be drained or removed from the scrap metal. If residual liquids cannot be eliminated, equipment floor liners or absorbent materials are alternatives to prevent leakage through the equipment floor. Product leakage through the equipment floor is prohibited! The height of the bulk scrap metal should be tapered downward from nose toward rear doors (see diagram illustration).

Note! *A bulk scrap metal shipment cannot include any individual object that weighs more than 1,500 lbs.* The nature of bulk scrap metal shipments is that the scrap is loaded several feet high in the container equipment. A shipment that contains an individual object that weighs 1,500+ lbs. presents an unacceptable risk of excessive weight concentration, which could result in structural equipment failure.

The rear of the load is secured with 2”x4” or 2”x6” bull boards. The bull boards may be inserted into the slotted door posts or corrugated sidewalls of the container equipment. The bull boards are nailed to vertical 2”x4” stabilizers in order to prevent displacement. If the scrap metal product is small enough in size to shift through the space between the bull boards, plywood buffer protection should be placed between the scrap metal and the bull boards. The scrap metal product at the rear of the container cannot exceed the height of the bull board barrier.

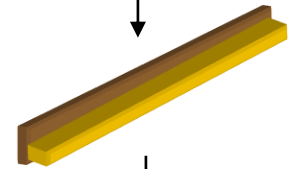
Bull Boards: The size and number of bull boards utilized will be determined by the net cargo weight that is being restrained. Based upon the “load restraining capacity” of 2”x4” and 2”x6” bull boards summarized on the loading diagram, a 40,000 lb. load would require securement with five 2”x6” bull boards.

SCRAP METAL

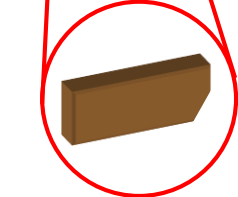
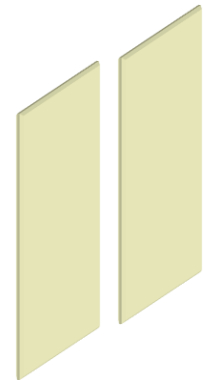


LOAD RESTRAINING CAPACITY	
RESTRAINT DEVICE	CAPACITY
2" X 4" BULL BOARD	5,600 LBS
2" X 6" BULL BOARD	8,000 LBS
2" X 4" "T" BRACE	7,000 LBS

"T" BRACE METHOD OF REINFORCING BULL BOARD. SHOWN BACKWARDS FOR CLARITY.



PLYWOOD BUFFER MATERIAL PLACED BETWEEN LADING & BULL BOARDS HELP EVENLY DISTRIBUTE LADING FORCES



MITER CORNERS TO SIMPLIFY DROPPING BULL BOARDS IN PLACE

SCRAP METAL LOAD SECUREMENT

- 1.) Bull Boards Secured into Slotted Doorposts at Rear of Load. Plywood Buffer Protection placed between Scrap Metal and Bull Boards.
- 2.) Under **No Circumstances** can a Cylindrical-Shaped Object that Weighs more than 3,500 Lbs. be Loaded Directly on Floor of Equipment. The Scrap Metal Object must be Secured on Pallet, Skid, Bearing Pieces, Etc., that Properly Distribute Concentrated Weight.

DRUMS

(Various Products)



Floor Stacked 55-Gallon Drums (4 – 3 - 4 Pattern) Braced with Ty-Gard™ Barriers 45+' Equipment

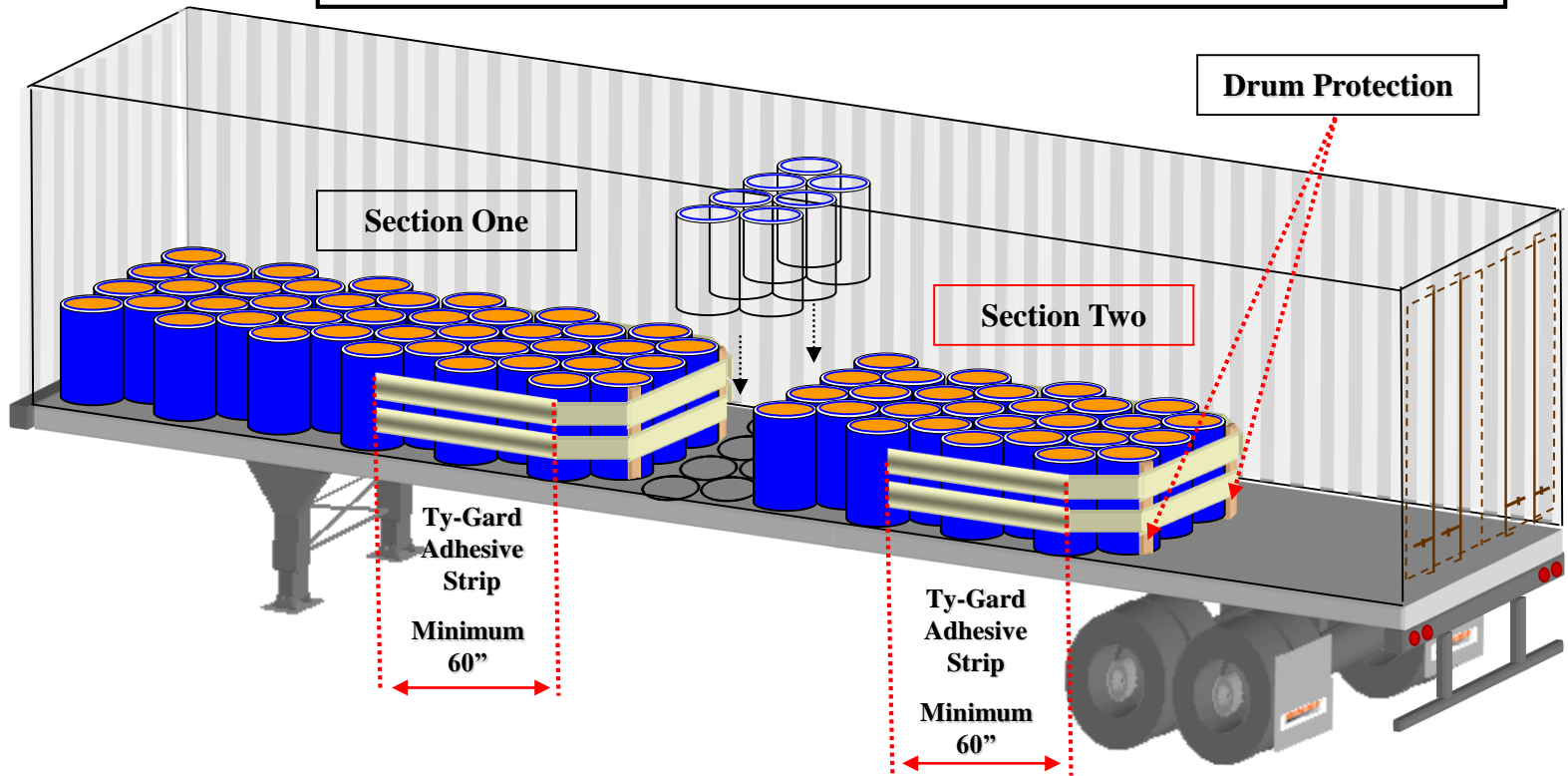
The following loading and securement method is for drums loaded in a 4-3-4 pattern only. The drums are restrained with Ty-Gard barriers that are attached to the sidewalls of the trailer/container.

The drums are loaded into two sections, each containing approximately half of the load. The last stack in each section should contain three drums.

Each section of drums is secured with two 15" wide strips of the Ty-Gard bulkhead material. The Ty-Gard is attached to the sidewalls with an adhesive strip a minimum of 60" long and at least 36" back from the face of the load. Note: When used with containers with corrugated sidewalls, follow the contour of the corrugations.

Drum protection consists of drum protectors or angleboard strips. If angleboard strips are utilized, three thicknesses of .250" solid fiberboard or equivalent are used at the rear barrier (closest door) and two thicknesses are used at the center barrier.

The Ty-Gard barriers should be closed and sealed for each section in accordance with manufacturer's instructions. The bulkhead barriers should be taped to the drum protectors to prevent slippage during transportation.

**Palletized 55-Gallon Drums (4-3-4 Pattern) Secured With Ty-Gard™
45+' Container Equipment****BLOCKING/BRACING OF INTERMODAL SHIPMENT**

- 1.) Drums Loaded into Two Sections, Each Containing Approximately Half the Load. The Last Stack in each Section should Contain Three Drums.
- 2.) Each Section is Secured with Two 15" Strips of Ty-Gard. The Adhesive Strip Attached to the Sidewalls must be Minimum 60" Length and at least 36" Back from Face of Load. Close and Seal Ty-Gard Barriers for each Section per Manufacturer's Instructions. The Barriers should be Taped in Place.
- 3.) Drum Protection Consists of Drum Protectors or Angleboard Strips. Thickness of Drum Protection Minimum 3/4" for Section Two & 1/2" for Section One.

Floor Stacked 55-Gallon Drums (4 - 4 Pattern) - Braced with Bull Boards 20' Equipment

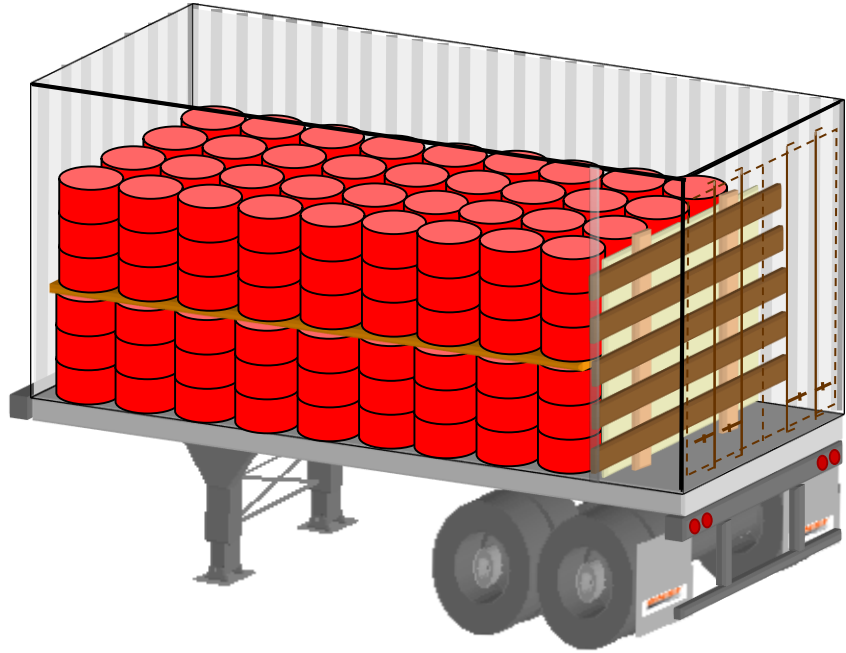
The following loading and securement method is for drums loaded two layers high in a 4 - 4 pattern (72 drums). The layer separators should consist of plywood (½") or equivalent strength material. The drums are restrained with bull boards that are inserted into the slotted door posts or corrugated sidewalls at the rear of the load.

The rear of the load is secured with 2"x4" or 2"x6" bull boards in order to restrict longitudinal movement of cargo. The bull boards may be inserted into the slotted door posts or corrugated sidewalls of the container equipment. The bull boards are nailed to vertical 2"x4" stabilizers in order to prevent displacement. Plywood buffer protection (½") is required between the cargo and the bull boards.

Bull Boards: The size and number of bull boards utilized will be determined by the net cargo weight that is being restrained. Based upon the "load restraining capacity" of 2"x4" and 2"x6" bull boards summarized on the loading diagram, a 40,000 lb. load would require securement with five 2"x6" bull boards.

**55-Gallon Drums (4-4 Pattern) Secured with Bull Boards
20' Container Equipment**

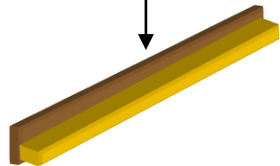
NOSE



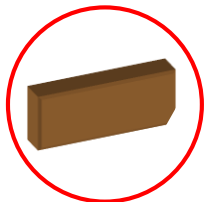
REAR

LOAD RESTRAINING CAPACITY	
RESTRAINT DEVICE	CAPACITY
2" X 4" BULL BOARD	5,600 LBS
2" X 6" BULL BOARD	8,000 LBS
2" X 4" "T" BRACE	7,000 LBS

"T" BRACE METHOD OF REINFORCING BULL BOARD. SHOWN BACKWARDS FOR CLARITY.



MITER CORNERS TO SIMPLIFY DROPPING BULL BOARDS INTO SLOTTED DOOR POSTS



BLOCKING/BRACING OF INTERMODAL SHIPMENT

- 1.) 72 Drums Loaded in 4-4 Pattern from Nose to Rear of Equipment.
- 2.) Plywood Layer Separator (Minimum ½") Required. Plywood Buffer Material (Minimum ½") placed between Drums and Bull Boards.
- 3.) Diagram Illustration of Bull Boards Inserted into Corrugated Sidewalls of Equipment. Bull Boards may also be Inserted into Slotted Door Posts. Bull Boards secured to Vertical 2"x4" Stabilizers to Prevent Displacement.

Palletized 55-Gallon Drums (4 - 4 Pattern) Braced with Ty-Gard™ Barriers 45+' Equipment

The following loading and securement method is for palletized drums loaded in a 4 - 4 pattern only. The drums are restrained with Ty-Gard barriers that are attached to the sidewalls of the trailer or container equipment.

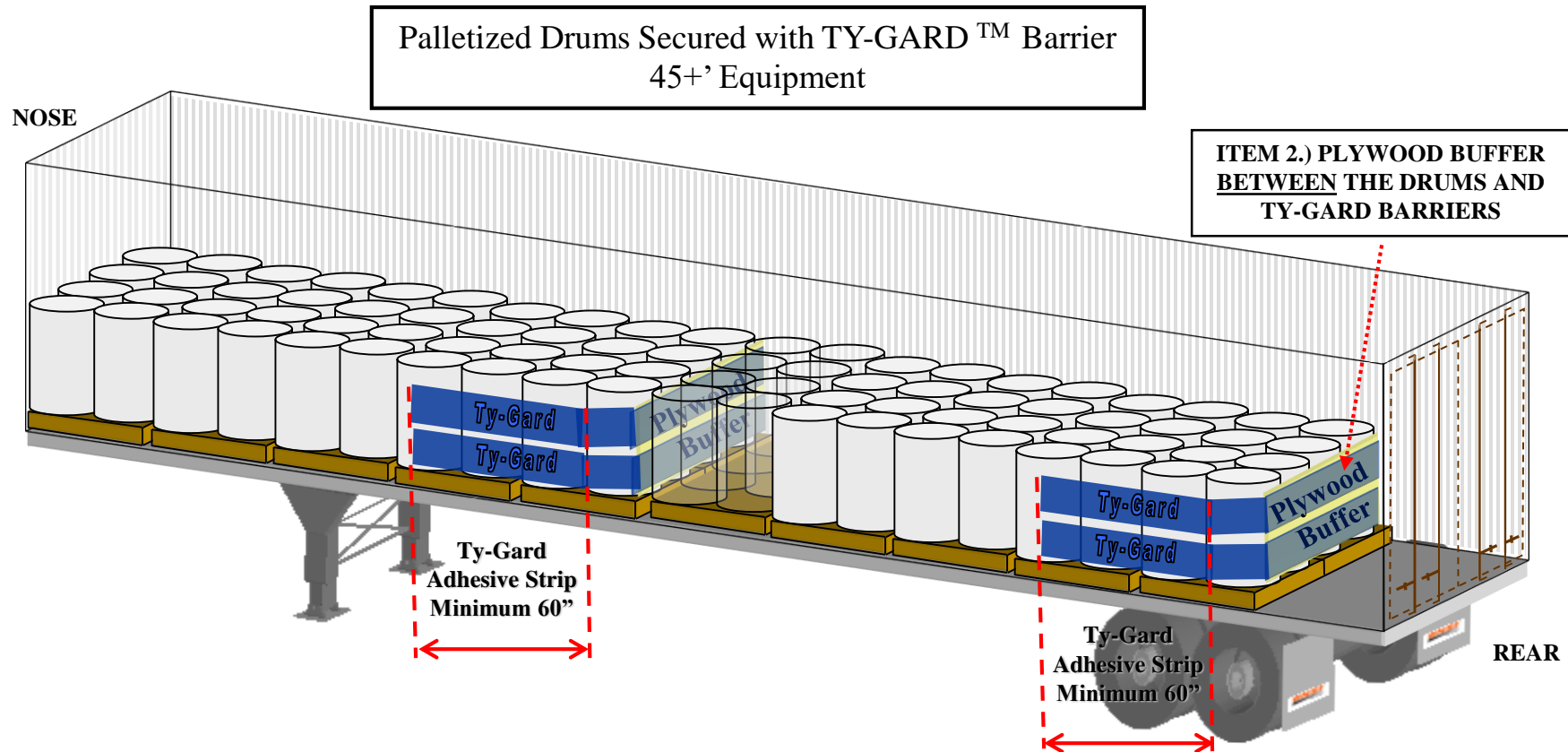
The drums are loaded four per pallet and divided into two sections, each containing half of the load. The drums are unitized to the pallet with banding (not illustrated in the diagram). Minimal ($\frac{1}{2}$ ") product underhang of the pallet is permitted. Pallets should be free of protruding nails that can damage drums.

If a significant lateral center void is present between each pair of palletized drums, suitable void filler must be utilized.

Each section of drums is secured with two 15" wide strips of the Ty-Gard bulkhead material. The Ty-Gard is attached to the sidewalls with an adhesive strip a minimum of 60" long and at least 36" back from the face of the load. Note: When used with containers with corrugated sidewalls, follow the contour of the corrugations.

One plywood buffer sheet ($\frac{1}{2}$ ") should be placed between the drums and Ty-Gard barriers at center and rear of load. The plywood buffer sheet should be six-feet in length and equal to height of load.

The Ty-Gard barriers should be closed, sealed and tensioned for each section in accordance with manufacturer's instructions. The bulkhead barriers should be taped into place in order to prevent slippage during transportation.



BLOCKING/BRACING OF INTERMODAL SHIPMENT

- 1.) Drums Loaded Four per Pallet. Pallets Loaded Two Wide from Nose to Rear of Equipment. Drums Unitized to Pallet with Banding (Not Shown in Diagram). **Minimal** (½") Product Underhang of Pallet Permitted.
- 2.) Lading Secured with Two 15" Strips of Ty-Gard at Center and Rear of Load. A Plywood Buffer Sheet (½") is placed between Drums and Ty-Gard Barriers. The Adhesive Strip Attached to the Sidewalls must be Minimum 60" Length. Ty-Gard Barriers for each Section should be Closed/Sealed per Manufacturer's Instructions. The Barriers should be Taped in Place.
- 3.) If Center Void is present between Palletized Drums, Suitable Void Filler must be Utilized.

Palletized 55-Gallon Drums (4 - 4 Pattern) Braced with Ty-Gard™ Barriers 20' Equipment

The following loading and securement method is for palletized drums loaded two layers high in a 4 - 4 pattern. The layer separators should consist of plywood (½") or equivalent strength material. The drums are restrained with Ty-Gard barriers that are attached to the sidewalls of the trailer or container equipment.

The drums are loaded four per pallet and divided into two sections (nose-rear) for each layer. The nose section of each layer would include four pallets and the rear section of each layer six pallets, for a total of ten pallets and 40 drums per layer, twenty pallets and 80 drums total. Minimal (½") product underhang of the pallet is permitted. Pallets should be free of protruding nails that can damage drums.

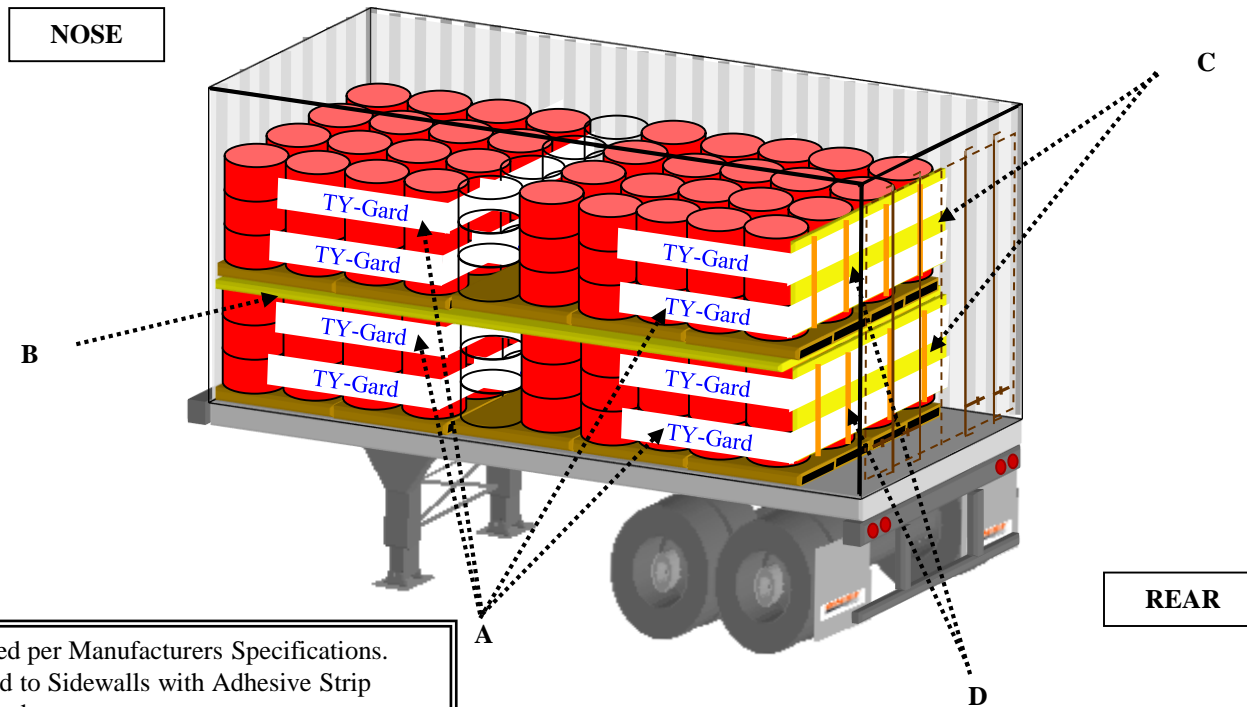
If a significant lateral center void is present between each pair of palletized drums, suitable void filler must be utilized.

Each section of drums for each layer is secured with two 15" wide strips of the Ty-Gard bulkhead material. The Ty-Gard is attached to the sidewalls with an adhesive strip a minimum of 60" long and at least 36" back from the face of the load. Note: When used with containers with corrugated sidewalls, follow the contour of the corrugations.

One plywood buffer sheet (½") should be placed between the drums and Ty-Gard barriers for each layer at center and rear of load. The plywood buffer sheet should be six-feet in length and equal to height of load.

The Ty-Gard barriers should be closed, sealed and tensioned for each section in accordance with manufacturer's instructions. The bulkhead barriers should be taped into place in order to prevent slippage during transportation.

**Palletized 55-Gallon Drums (4 – 4 Pattern) Secured With Ty-Gard™
20' Container Equipment**



A- Ty-Gard Applied per Manufacturers Specifications. Ty-Gard is attached to Sidewalls with Adhesive Strip Minimum 60” Length.

B- Plywood Layer Separator-Minimum ½” thickness

C- 4’ x 6’ Plywood Buffer Protection

D- Tape Securing Ty-Gard.

THIS DRAWING IS DESIGNED TO ILLUSTRATE ACCEPTED LOADING PRACTICES AND DOORWAY PROTECTION. THE NUMBER OF UNITS MAY VARY ACCORDING TO WEIGHTS, CONTAINER SIZE AND CAPACITY. IT IS NOT TO SCALE.

LOGS

(Rough Cut - Stacked)



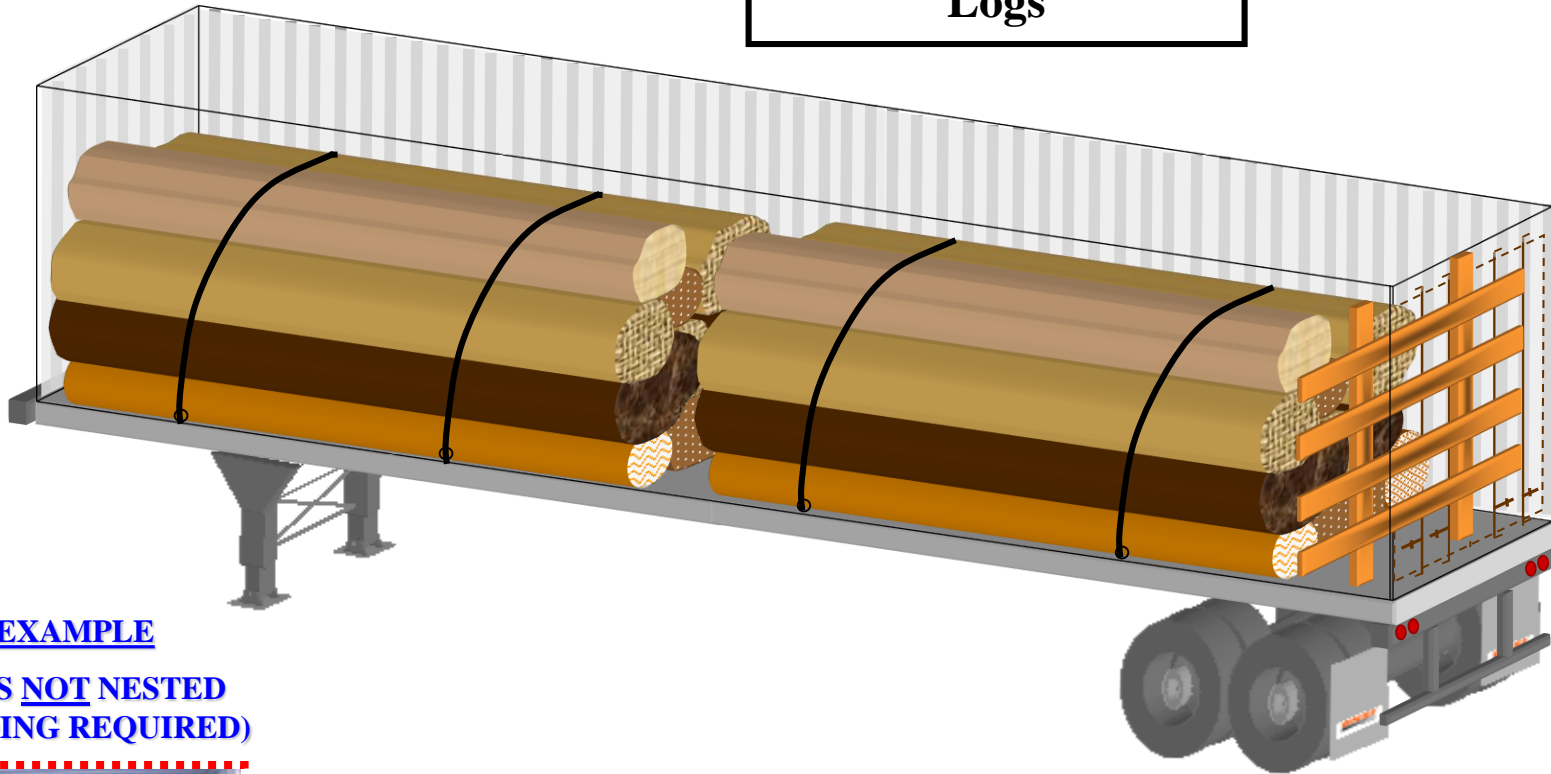
**Logs defined as a “restricted commodity” on BNSF Railway.
See BNSF Intermodal Rules & Policies Guide Item 43.**

Logs (Rough Cut with Bark Attached) – Corrugated Wall Container Equipment Braced with Bull Boards at Rear of Load

This loading and securement method is approved for rough cut logs in corrugated wall container equipment. The logs can be loaded in two, three or four sections; secured by means of two-inch steel banding and 2" x 6" bull boards.

- 1.) The load is divided into two-four sections, with weight evenly distributed both longitudinally and laterally in the container.**
- 2.) Logs in each section are loaded with the large-diameter end alternated from nose to rear of container equipment.**
- 3.) Two 2" x .031" steel unitizing bands MUST be tautly applied to each section of logs loaded in the container. The bands can be attached to floor securement rings of the container or completely encircle each section. The diagram illustrates steel unitizing bands secured to floor securement rings. No unitizing bands are required when the section(s) of logs are nested a minimum of one-third the log diameter.**
- 4.) Bull boards (2" x 6") may be inserted in the slotted door posts or corrugated sidewalls of equipment at the rear of the load. One hardwood bull board is required per layer of logs (minimum of four). The bull boards are nailed to vertical 2"x4" stabilizers in order to prevent displacement.**

Logs



EXAMPLE

**LOGS NOT NESTED
(BANDING REQUIRED)**



LOGS Defined as “Restricted Commodity” on BNSF Railway

- 1.) Weight of Logs Evenly Distributed Lengthwise & Crosswise in Steamship Container.
- 2.) Large-Diameter End of Logs Alternated from Nose to Rear for Each Section of Logs.
- 3.) Steel Unitizing Bands (2” x .031”) Secured to Equipment Floor Rings and Crimped Over Top of Stacked Logs. No Banding Required When Logs are Nested Minimum of One-Third the Log Diameter.
- 4.) Bull Boards Inserted into Rear Door Slots or Corrugated Sidewalls of Equipment at Rear of Load. One 2” x 6” Hardwood Bull Board Required per Layer of Logs (Minimum of Four).

BAGGED PRODUCT



Bags on Pallets or Slip Sheets - Secured With 2x6 Bull Boards

Palletized or slip-sheet bagged product with either shrink-wrap or stretch-wrap in accordance with manufacturer's specifications.

Units are loaded two wide and turned laterally (longest side perpendicular to equipment sidewalls) to eliminate lateral void, stowed from the nose to the doors with product-to-product contact. The second layer is stowed on plywood decking, 4' x 8' x 1/2" (width of container minus 1").

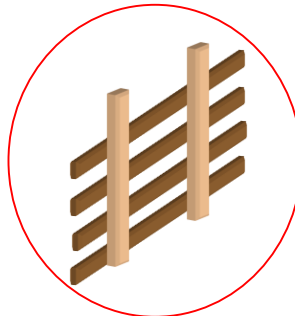
When product underhang of the pallet exists it is possible for the product to migrate/move on the pallet, which has the potential to cause product damage. Product underhang of the pallet is considered void space and should be filled with recommended dunnage material.

Cargo secured with 2x4 or 2x6 bull boards inserted into the slotted doorposts or in the corrugated sidewalls. Two vertical 2x4's are secured to the horizontal bull boards to prevent displacement and to add support. Miter corners of bull boards to simplify dropping of bull boards into slotted doorposts.

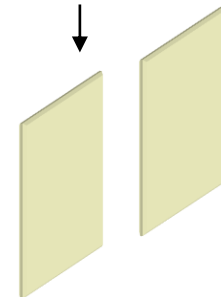
Optional: plywood buffer material can be placed between lading and bull boards to help evenly distribute cargo forces. (Not shown in diagram).

Bullboard Application

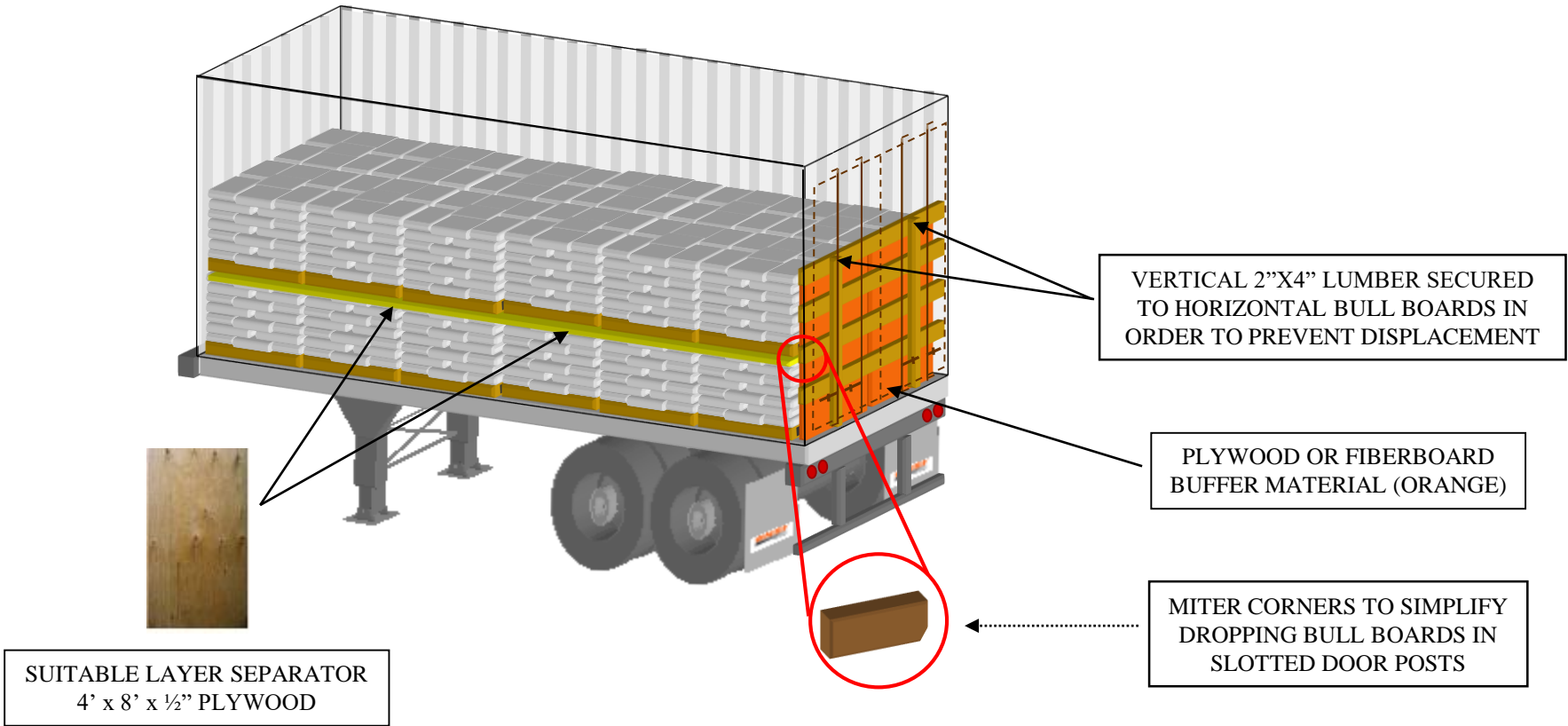
LOAD RESTRAINING CAPACITY	
RESTRAINT DEVICE	CAPACITY
2" X 4" BULLBOARD BOARD	5,600 LBS
2" X 6" BULLBOARD BOARD	8,000 LBS
2" X 4" "T" BRACE	7,000 LBS



OPTIONAL: PLYWOOD BUFFER MATERIAL CAN BE PLACED BETWEEN CARGO AND BULL BOARDS TO HELP EVENLY DISTRIBUTE CARGO FORCES (NOT SHOWN IN DIAGRAM)



BAGGED PALLETIZED PRODUCT SECURED WITH BULL BOARDS IN 20' STEAMSHIP EQUIPMENT



THIS DRAWING IS DESIGNED TO ILLUSTRATE ACCEPTED LOADING PRACTICES AND DOORWAY PROTECTION. THE NUMBER OF UNITS MAY VARY ACCORDING TO WEIGHTS, CONTAINER SIZE AND CAPACITY. IT IS NOT DRAWN TO SCALE. ANY LATERAL VOID MUST BE FILLED WITH APPROPRIATE FILLER MATERIAL

Bags on Pallets or Slip Sheets - Secured with TY-GARD™

20' Equipment

Palletized or slip-sheet bagged product with either shrink-wrap or stretch-wrap in accordance with manufacturer's specifications.

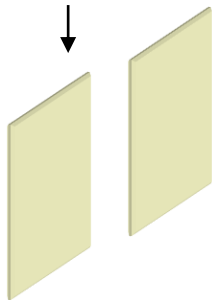
Units are loaded two wide and turned laterally (longest side perpendicular to equipment sidewalls) to eliminate lateral void, stowed from the nose to the doors with product-to-product contact. The second layer is stowed on plywood decking, 4' x 8' x ½" (width of container minus 1").

When product underhang of the pallet exists it is possible for the product to migrate/move on the pallet, which has the potential to cause product damage. Product underhang of the pallet is considered void space and should be filled with recommended dunnage material.

Ty-GARD applied per manufacturer's instructions, two strips equal one barrier, each layer secured with one barrier. The Ty-Gard is attached to the sidewalls with an adhesive strip a minimum of 60" long and at least 36" back from the face of the load. Note: When used with containers with ribbed/corrugated sidewalls, follow the contour of the corrugations.

Optional: plywood buffer material can be placed between cargo and bullboards to help evenly distribute cargo forces (not shown in diagram).

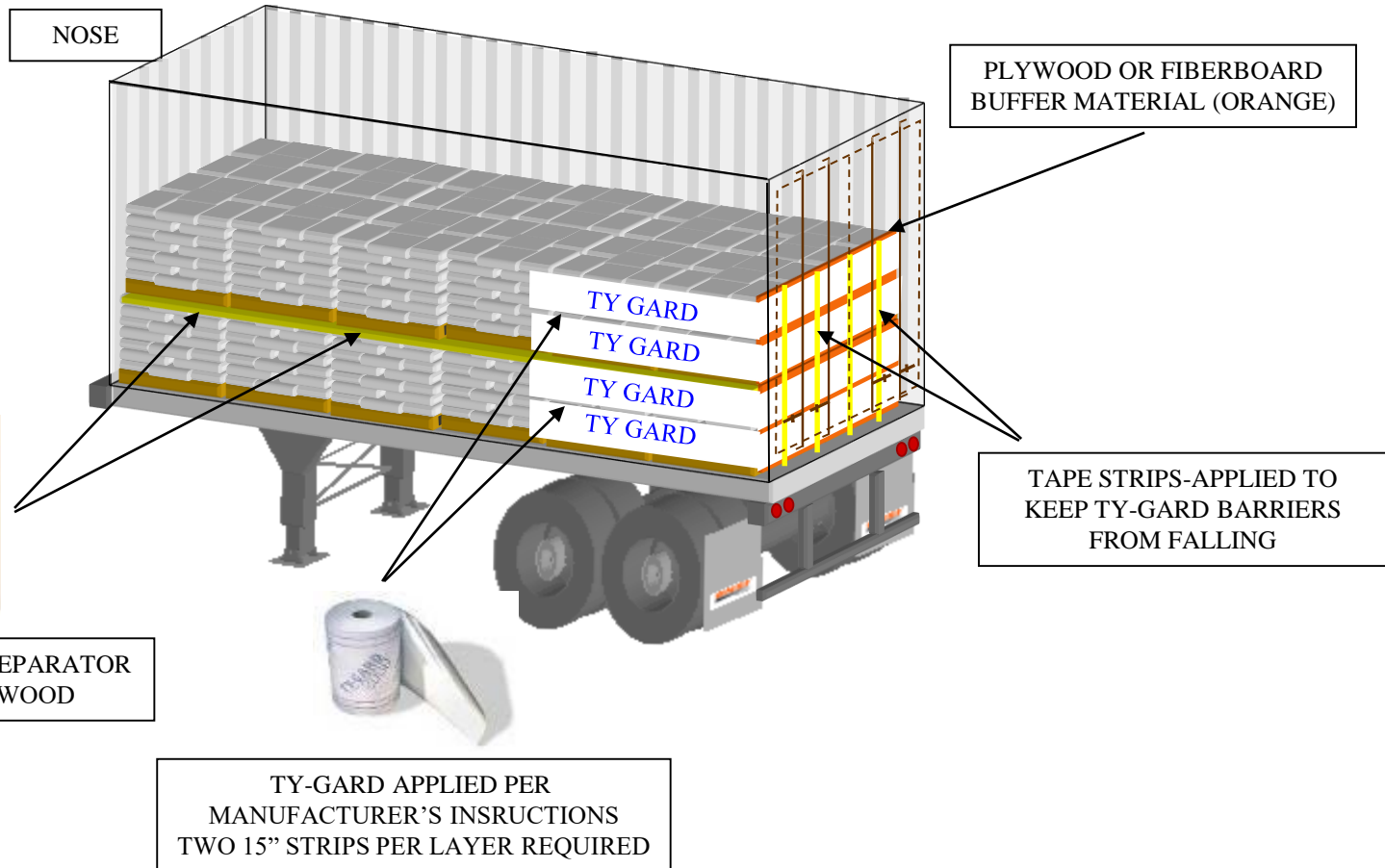
PLYWOOD BUFFER MATERIAL CAN BE
PLACED BETWEEN LADING & BULL BOARDS
TO HELP EVENLY DISTRIBUTE LADING
FORCES



TY-GARD Tools



BAGGED PALLETIZED PRODUCT SECURED WITH TY-GARD™ IN 20' EQUIPMENT



THIS DRAWING IS DESIGNED TO ILLUSTRATE ACCEPTED LOADING PRACTICES AND DOORWAY PROTECTION. THE NUMBER OF UNITS MAY VARY ACCORDING TO WEIGHTS, CONTAINER SIZE AND CAPACITY. IT IS NOT DRAWN TO SCALE. ANY LATERAL VOID MUST BE FILLED WITH APPROPRIATE FILLER MATERIAL

Bags on Pallets or Slip Sheets - Secured with D. I. D. Bags and Fillers

Palletized or slip-sheet bagged product with either shrink-wrap or stretch-wrap in accordance with manufacturer's specifications.

D. I. D. bags must be a minimum of 48" x 96" (Level 1 rating). Two airbags are utilized for load securement; the first is placed in the center of the load and the second at the rear of the load.

Units are loaded two wide with the 48" dimension longitudinally in order to "stretch out the load" and maintain proper OTR axle weights. The units are stowed along the sidewalls from the nose to the doorway area with product-to-product contact. All single units are centered and spread throughout the load.

To prevent lateral migration, single units are secured with saddle packs, and the centerline void for the two wide units filled with a fiberboard void filler of choice (as illustrated in the diagram).

When product underhang of the pallet exists it is possible for the product to migrate/move on the pallet, which has the potential to cause product damage. Product underhang of the pallet is considered void space and should be filled with recommended dunnage material.

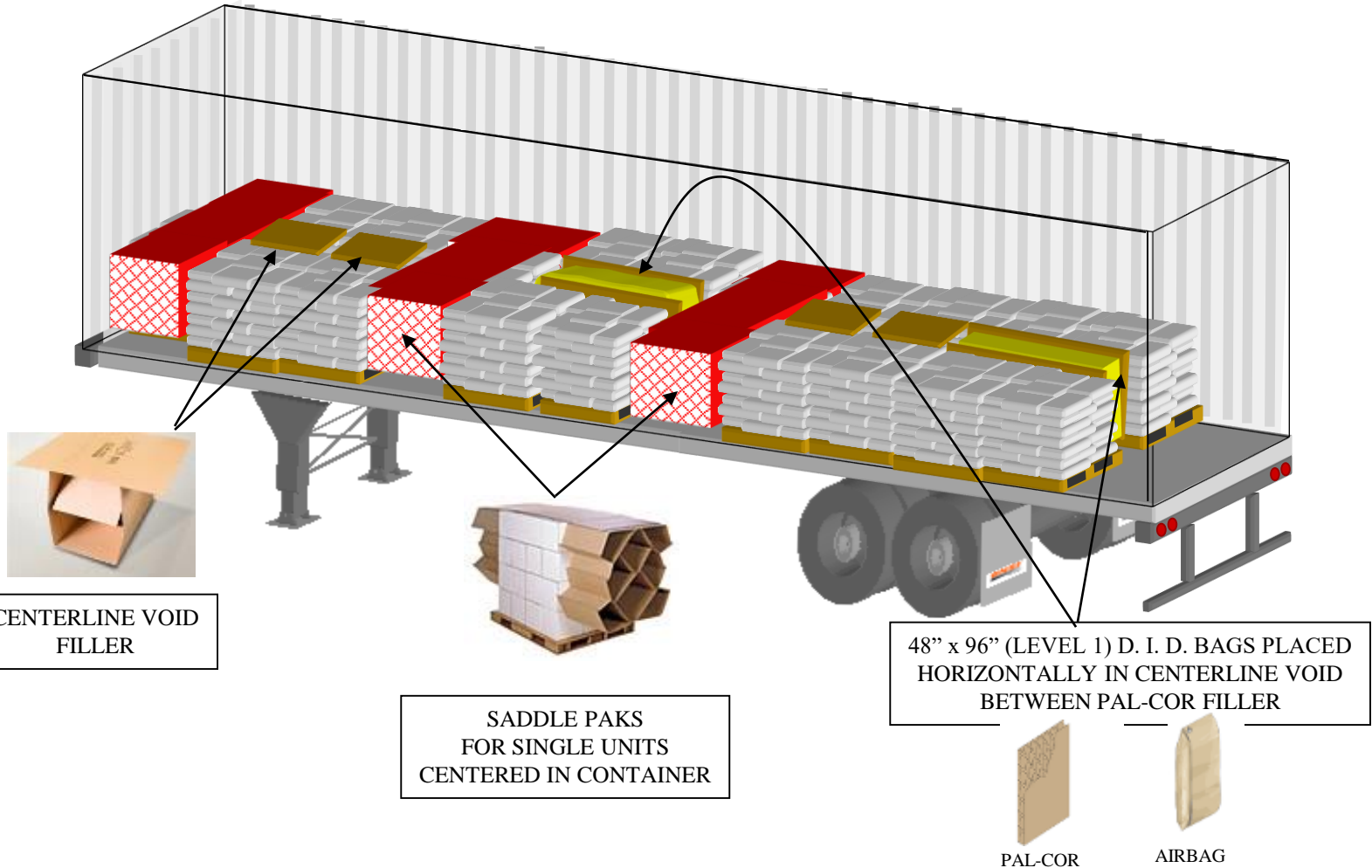
Disposable Inflatable Dunnage (D. I. D.) Bag Notes

The D. I. D. bag must not be used in a void space in excess of 12" wide. If the void space exceeds 12" width, additional full size fillers must be placed along side of the D. I. D bag or you must use a Stopak bag which is specifically designed for 14" to 24" voids.

After inflation the airbag should be located approximately 4" above the equipment floor. The airbag must be adequately buffered to prevent contact with sharp or rough edges that may puncture the bag. Maximum inflation of airbag is 2 PSI.

Leave a minimum of 24" space between the rear of the load and the container doors.

LOADING METHOD FOR PALLETIZED / STRETCH-WRAPPED BAGGED PRODUCT SECURED WITH D. I. D. BAGS AND FILLERS



Bags on Pallets or Slip Sheets Alternately Staggered - Secured with D. I. D. Bags

Palletized or slip-sheet bagged product with either shrink-wrap or stretch-wrap in accordance with manufacturer's specifications.

D. I. D bags must be a minimum of 48" x 96" (Level 1 rating). Two D. I. D. Bags are utilized for load securement; the first is placed in the center of the load and the second at the rear of the load.

Units are loaded two wide with the 48" dimension longitudinally in order to "stretch out the load" and maintain proper OTR axle weights. The units are alternately stowed along the sidewalls from the nose to the doorway area with product-to-product contact.

When product underhang of the pallet exists it is possible for the product to migrate/move on the pallet, which has the potential to cause product damage. Product underhang of the pallet is considered void space and should be filled with recommended dunnage material.

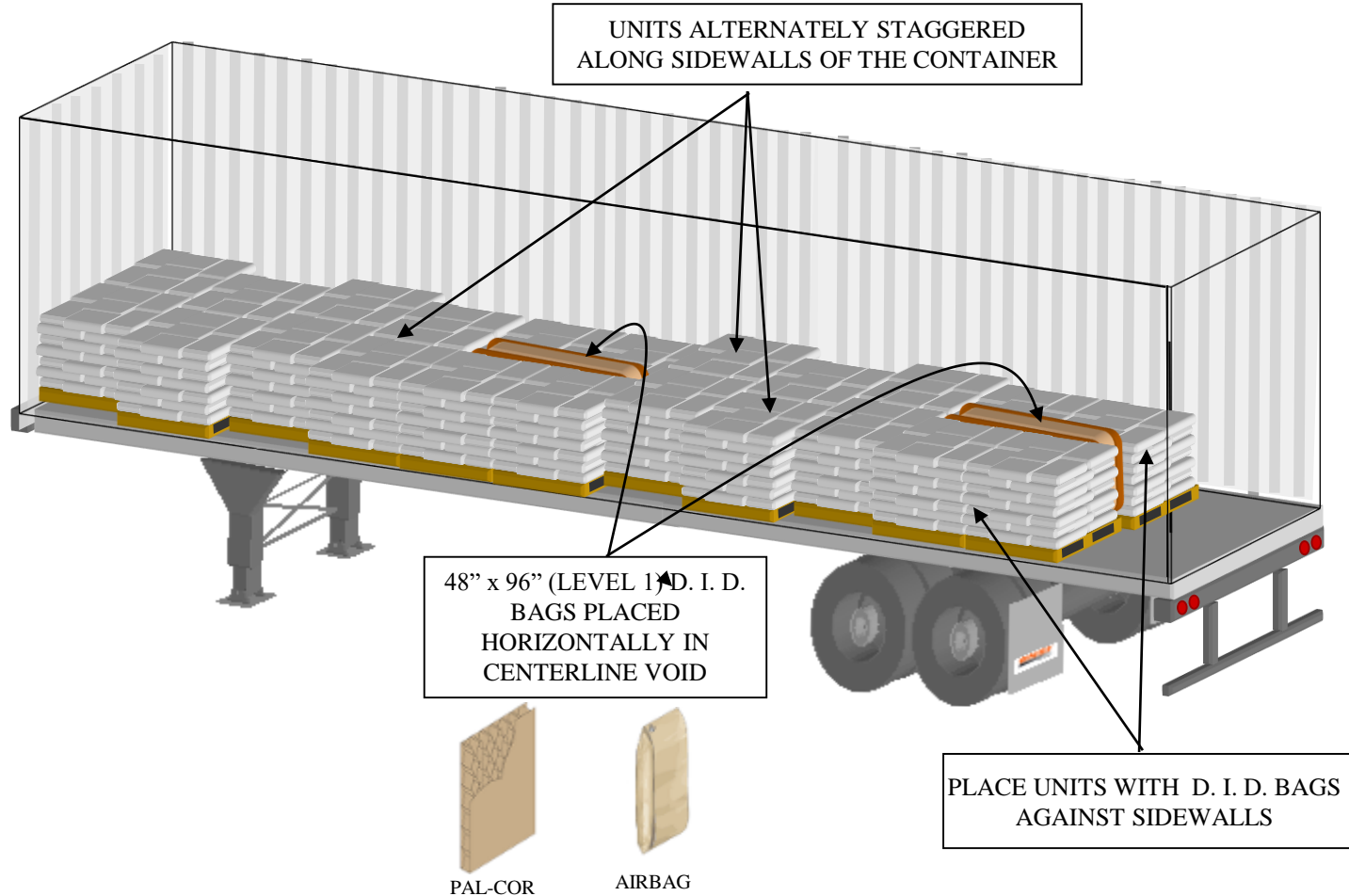
Disposable Inflatable Dunnage (D. I. D.) Bag Notes

The D. I. D. bag must not be used in a void space in excess of 12" wide. If the void space exceeds 12" width, additional full size fillers must be placed along side of the D. I. D bag or you must use a Stopak bag which is specifically designed for 14" to 24" voids.

After inflation, the airbag should be located approximately 4" above the equipment floor. The airbag must be adequately buffered to prevent contact with sharp or rough edges that may puncture the bag. Maximum inflation of airbag is 2 PSI.

Leave a minimum of 24" space between the rear of the load and the container doors.

**LOADING METHOD FOR PALLETIZED STRETCH-WRAPPED BAGGED PRODUCT (2 – 2 OFFSET PATTERN)
SECURED WITH D. I. D. BAGS**



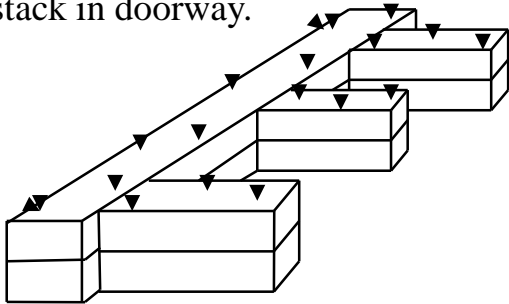
Bags on Pallets or Slip Sheets Alternately Staggered - Secured Laminated Floor Blocking

Palletized or slip-sheet bagged product with either shrink-wrap or stretch-wrap in accordance with manufacturer's specifications.

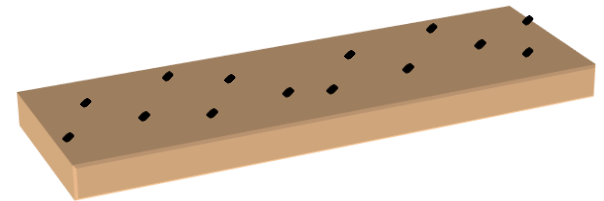
Units are loaded two wide with the 48" dimension lengthwise in order to "stretch out the load" and maintain proper OTR axle weights. The units are alternately stowed along the sidewalls from the nose to the doorway area with product-to-product contact.

When product underhang of the pallet exists it is possible for the product to migrate/move on the pallet, which has the potential to cause product damage. Product underhang of the pallet is considered void space and should be filled with recommended dunnage material.

Apply 2 – 2" x 6" x 96" laminated floor blocking with 3 - 2" x 6" x 18" laminated back-up cleats against last stack in doorway.



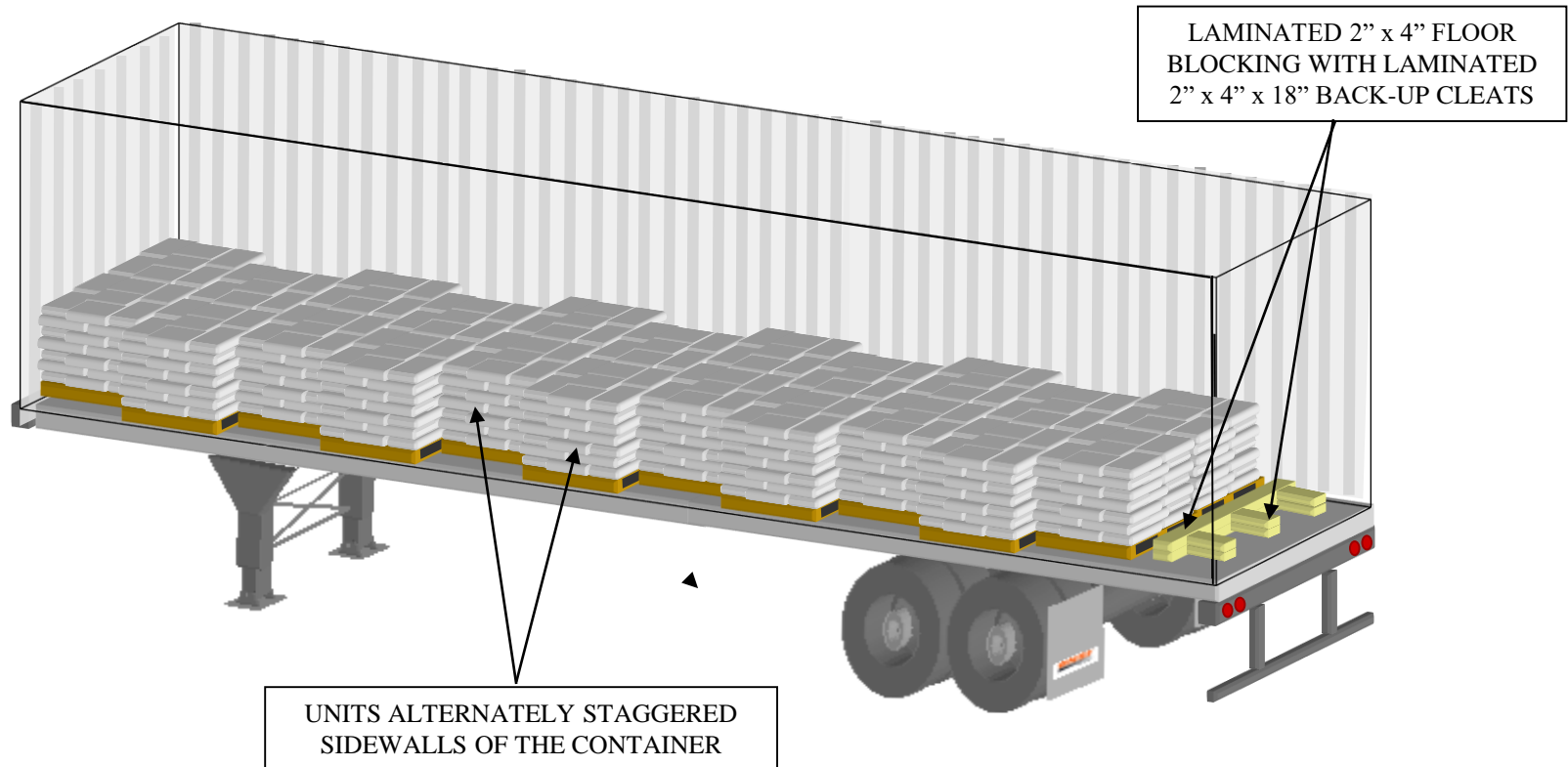
**LAMINATED 2" X 6" X 96"
FLOOR BLOCKING AND 2" X
6" X 18" BACK-UP CLEATS
(REAR OF LOAD)**



FLOOR BLOCKING SHOULD BE SECURELY NAILED TO THE TRAILER FLOOR AND MUST PENETRATE THE TRAILER FLOOR TO A DEPTH OF 1" OR MORE. THE NAILS SHOULD BE APPLIED IN A STAGGERED PATTERN, 4-6" APART.

Leave a minimum of 24" space between the rear of the load and the container doors.

**LOADING METHOD FOR PALLETIZED STRETCH-WRAPPED BAGGED PRODUCT (2 – 2 OFFSET PATTERN)
SECURED WITH LAMINATED 2" X 4" WOOD FLOOR BLOCKING**



Bags on Pallets or Slip Sheets - Secured with Lateral and Laminated Floor Blocking

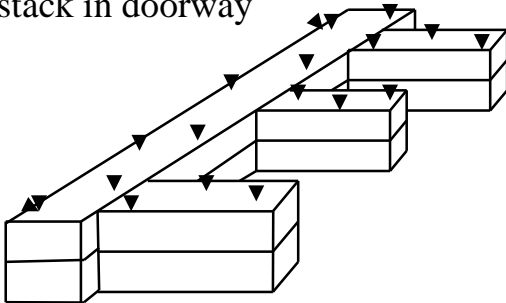
Palletized or slip-sheet bagged product with either shrink-wrap or stretch-wrap in accordance with manufacturer's specifications.

Units are loaded two wide with the 48" dimension lengthwise in order to "stretch out the load" and maintain proper OTR axle weights. The two wide units are alternately stowed along the sidewalls from the nose to the doorway area with product-to-product contact. All single units are centered and staggered throughout the load.

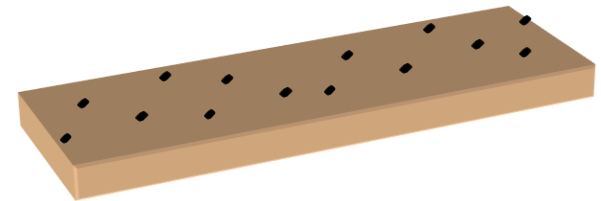
When product underhang of the pallet exists it is possible for the product to migrate/move on the pallet, which has the potential to cause product damage. Product underhang of the pallet is considered void space and should be filled with recommended dunnage material.

Apply 2"x 6" x 24" lateral (side) blocking to each side of single units as illustrated.

Apply 2 – 2" x 6" x 96" laminated floor blocking with 3 - 2" x 6" x 18" laminated back-up cleats against last stack in doorway



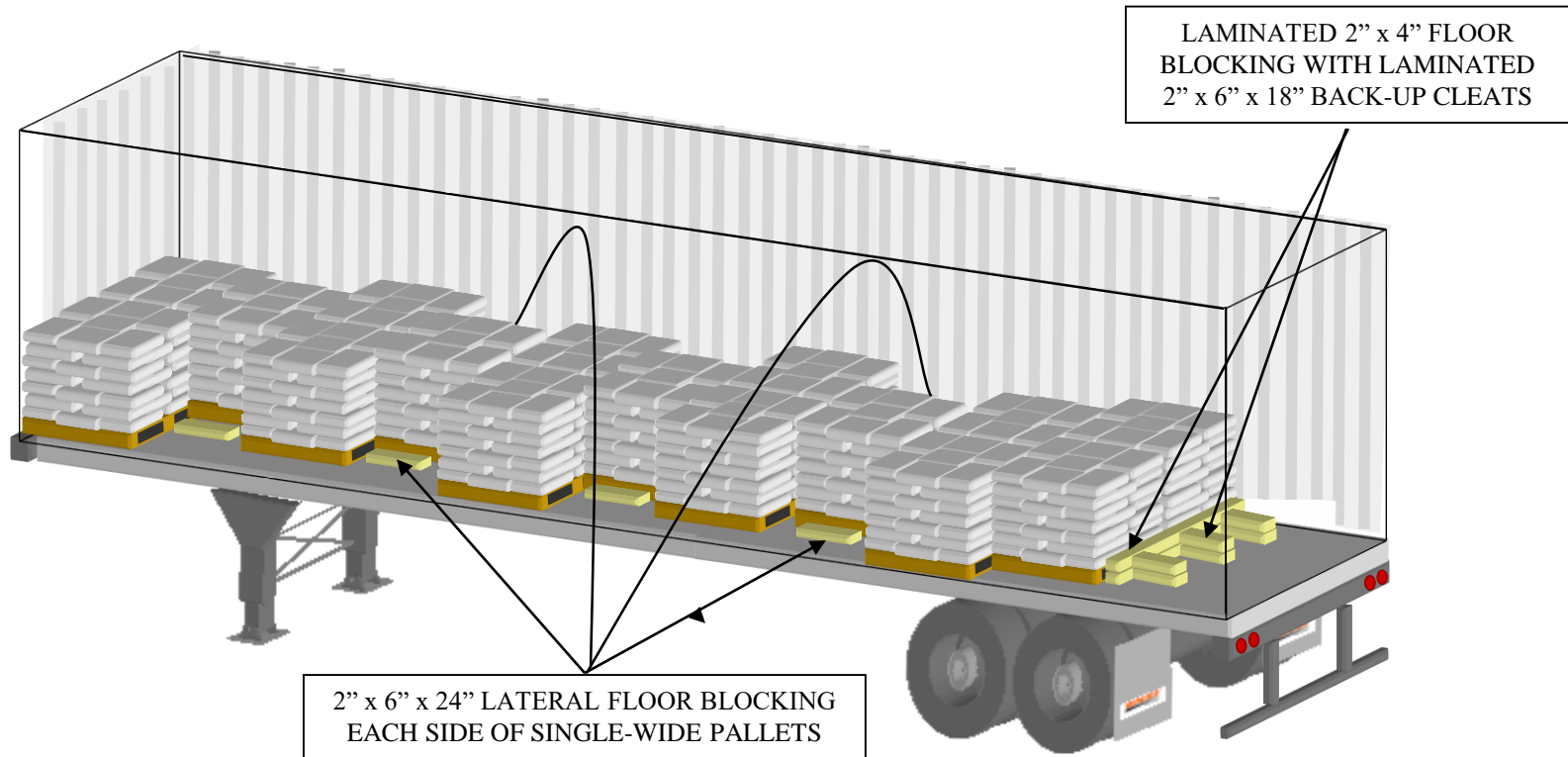
LAMINATED 2" X 6" X 96"
FLOOR BLOCKING AND 2" X
6" X 18" BACK-UP CLEATS
(REAR OF LOAD)



FLOOR BLOCKING SHOULD BE SECURELY NAILED TO THE TRAILER FLOOR AND MUST PENETRATE THE TRAILER FLOOR TO A DEPTH OF 1" OR MORE. THE NAILS SHOULD BE APPLIED IN A STAGGERED PATTERN, 4-6" APART.

Leave a minimum of 24" space between the rear of the load and the container doors.

**LOADING METHOD FOR PALLETIZED / STRETCH-WRAPPED BAGGED PRODUCT (SINGLES & DOUBLES)
SECURED WITH LAMINATED 2" X 4" WOOD FLOOR BLOCKING**



MACHINERY



Machinery / Pumping Units Loaded into a 40' Steamship Container Secured with Laminated Floor Blocking

For pumping units stowed in a 40' wooden floor steamship container for intermodal service, plan the load to equalize the weight on each side of the container the entire length of the container. A balanced load is required for the stability and success of this loading pattern.

The pumping units and other items, having a high center of gravity or narrow base, must be secured to prevent them from tipping over in transit.

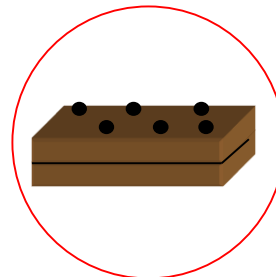
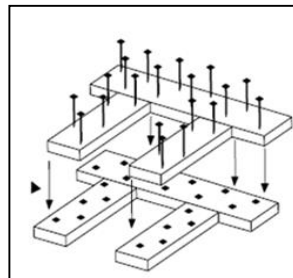
Warning! Extremely concentrated weight may result in container floor failure! Weight of machine must not exceed 2,500 lbs per linear foot or 25,000 lbs per ten linear feet. Securement of pumping units by steel cables to container sidewall or floor tie-down anchors **cannot** be the **only** means of securement.

The pumping unit front and back must be secured with laminated 2" x 6" wood floor blocking with laminated back-up cleats equal to the width of the unit to prevent lengthwise movement. Six 2" x 6" laminated side blocking per side, equally spaced must be utilized to prevent lateral movement. All lumber used for blocking and bracing must be of sound material, free of defects which impair its strength or interfere with proper nailing.

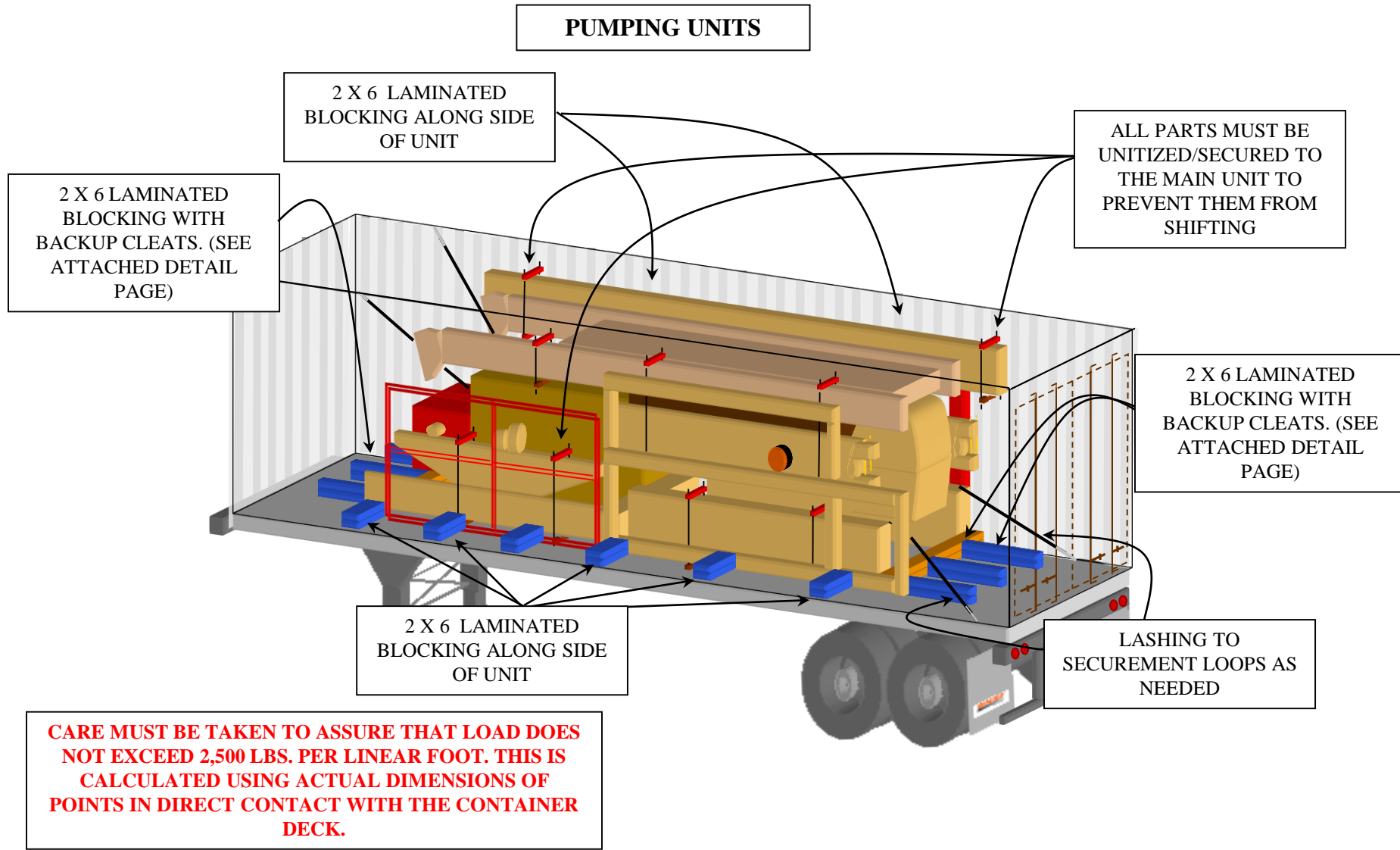
Floor Blocking Requirements

Floor blocking should be securely nailed to the trailer floor and must penetrate the trailer floor to a depth of 1" or more. The nails should be applied in a staggered pattern, 4-6" apart. 2" x 6"x 24" back-up and side cleats are to be laminated two high, each layer nailed. One 16d nail has approximately holding power of 1,000 lbs., use adequate number of nails for the weight involved.

Laminated Floor Blocking



Laminated Side Blocking



Heavy Machinery Loaded into a 40' Steamship Container Secured with Wood Floor Blocking

Heavy machinery stowed in a 40' wooden floor steamship container for intermodal service, plan the load to equalize the weight on each side of the container, throughout the entire length of the container. A balanced load is required for the stability and success of this loading pattern.

Any machinery and other items, having a high center of gravity or narrow base, must be secured to prevent them from tipping over in transit. Weight of machine must not exceed 2,500 lbs per linear foot.

In order not to exceed 2,500 lbs per linear foot or 25,000 lbs per ten linear feet, machinery must be stowed on top of a minimum of four 2x6 or 4x4 load bearing pieces extending three feet beyond each end of machine.

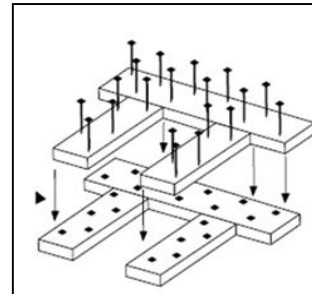
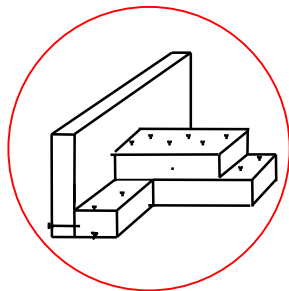
All lumber used for blocking and bracing must be of sound material, free of defects which impair its strength or interfere with proper nailing.

Total number of machines may vary dependent upon weight. The machinery should be evenly spaced apart throughout the container, and laterally centered to allow floor blocking on all sides.

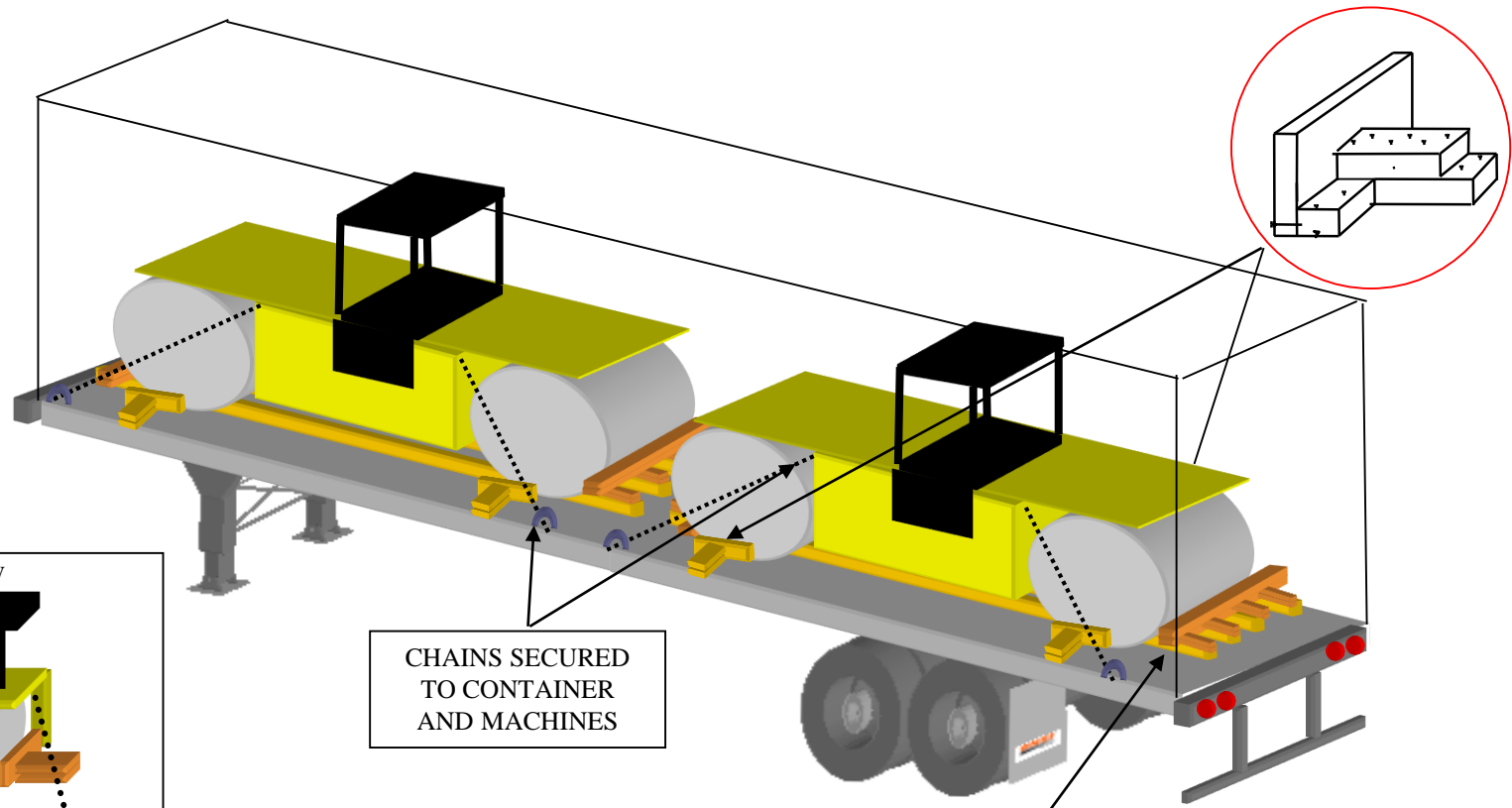
The sides of each wheel are braced with laminated 2" x 6" x (width of tires) floor blocking as illustrated in diagram. The front and the back of each machine are secured in the same manner, in addition to chains secured to the machine and container tie-down floor anchors.

Floor Blocking Requirements

Floor blocking should be securely nailed to the trailer floor and must penetrate the trailer floor to a depth of 1" or more with 16D nails. The nails should be applied in a staggered pattern, 4-6" apart. 2" x 6"x 24" back-up and side cleats are to be laminated two high, each layer nailed.



MACHINERY LOADED INTO 40-FT STEAMSHIP CONTAINERS

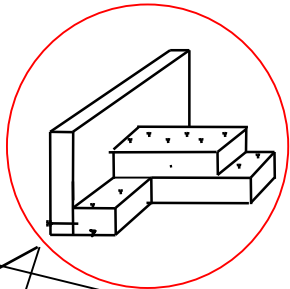


END VIEW

MACHINERY STOWED ON TOP OF 4 – 2" X 6" **BEARING PIECES** EXTENDING 3' BEYOND EACH END OF MACHINE. **LAMINATED FLOOR BLOCKING** ADDED ON TOP OF BEARING PIECES AND SIDES OF ROLLERS. CHAINED FRONT AND BACK EACH SIDE

CHAINS SECURED TO CONTAINER AND MACHINES

LAMINATED 2" x 6" LAMINATED FLOOR BLOCKING ON TOP OF 2" X 6" BEARING PIECES



Forklifts (5,000 to 8,000 lbs) Loaded into a 53' Container-Secured with Wood Floor Blocking

Forklifts stowed in a 53' wooden floor container for intermodal service. Plan the load to equalize the weight on each side of the container, the entire length of the container. A balanced load is required for the stability and success of this loading pattern.

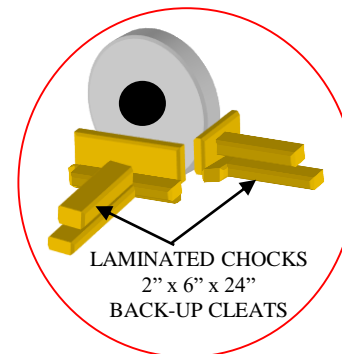
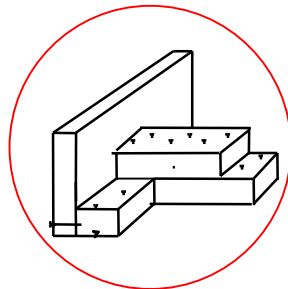
Forklifts and other items, having a high center of gravity or narrow base, must be secured to prevent them from tipping over in transit. Weight of machine must not exceed 2,500 lbs per linear foot.

All lumber used for blocking and bracing must be of sound material, free of defects which impair its strength or interfere with proper nailing. Total number of forklifts may vary dependent upon weight. The forklifts should be evenly spaced apart throughout the container, and laterally centered in order to allow floor blocking on all sides.

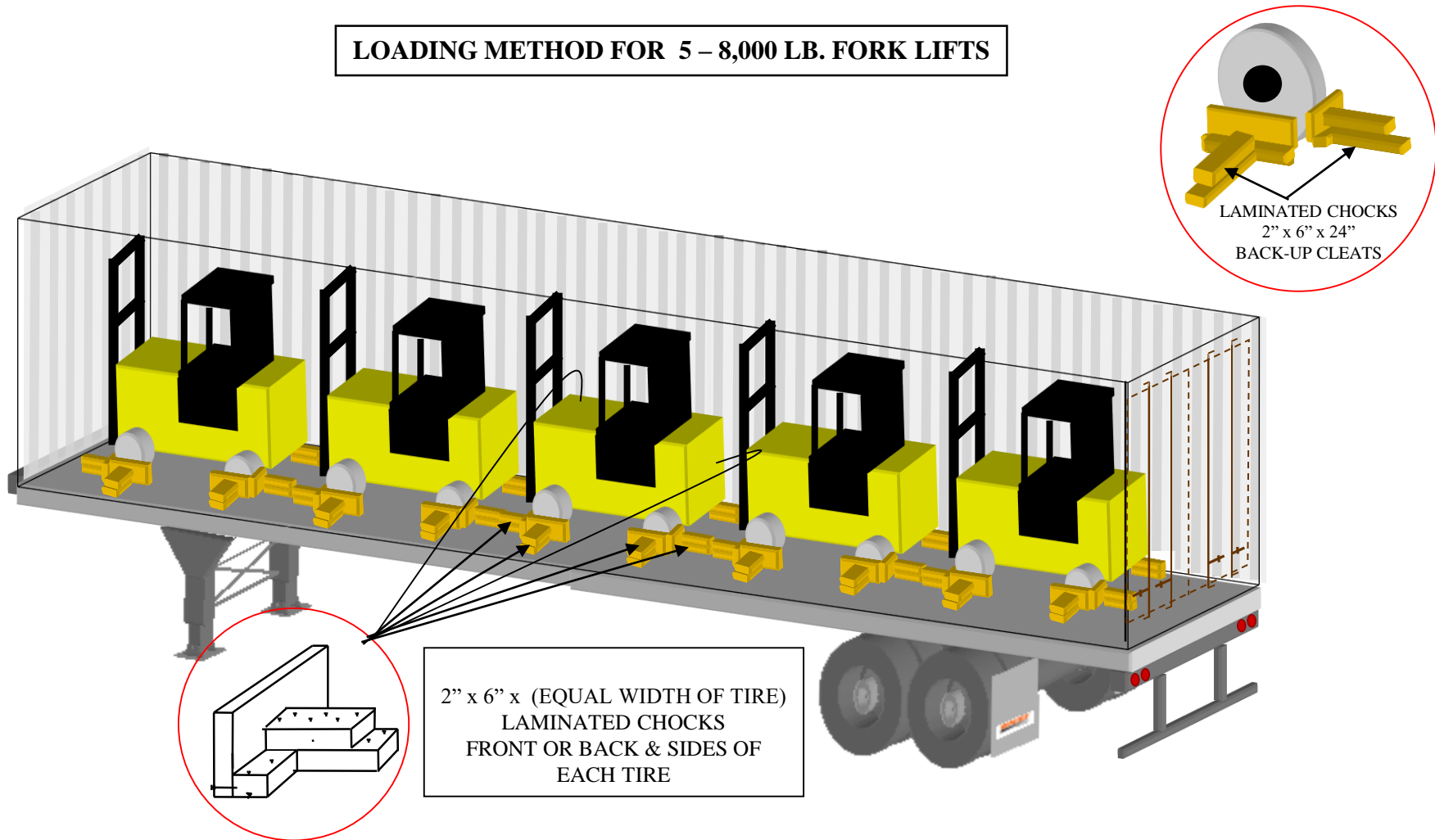
The sides of each wheel are braced with laminated 2" x 6" x (width of tires) floor blocking as illustrated in diagram. The fronts of the front tires and the back of the back tires for each forklift are secured in the same manner.

Floor Blocking Requirements

Floor blocking should be securely nailed to the trailer floor and must penetrate the trailer floor to a depth of 1" or more. The nails should be applied in a staggered pattern, 4-6" apart. The 2" x 6" x 24" back-up and side cleats are to be laminated two high, each layer nailed into the floor with 5 - 16d nails or 6 - 14d nails. One 16d nail has approximately holding power of 1,000 lbs., use adequate number of nails for the weight involved.



LOADING METHOD FOR 5 – 8,000 LB. FORK LIFTS



2" x 6" x 24" BACK-UP & SIDE CLEATS ARE TO BE LAMINATED TWO HIGH, EACH LAYER NAILED INTO THE FLOOR WITH 5 - 16D NAILS OR 6 - 14D NAILS, NAILS MUST PENETRATE 1-1/2". SHIPPER IS RESPONSIBLE FOR PROPER WEIGHT DISTRIBUTION, NUMBER OF UNITS MAY VARY DEPENDING ON WEIGHT OF FORKLIFTS
UNITS MUST NOT BE STOWED TWO WIDE DUE TO WEIGHT LIMITATION – WEIGHT NOT TO EXCEED 2,500 LBS PER LINEAR FOOT

FLOOR / CERAMIC TILE

(Pallets / Skids)



Palletized Cases of Tile (One Row) Secured with Wood Floor Blocking

Palletized cases of tile (floor, ceramic, etc.) are unitized with shrink-wrap or stretch-wrap and plastic bands, in accordance with the manufacturer's specifications. Cases are *secured to the pallet* with plastic or steel bands in order to eliminate the risk of product migration (product movement off pallet). Note: Product migration increases the risk of product damage.

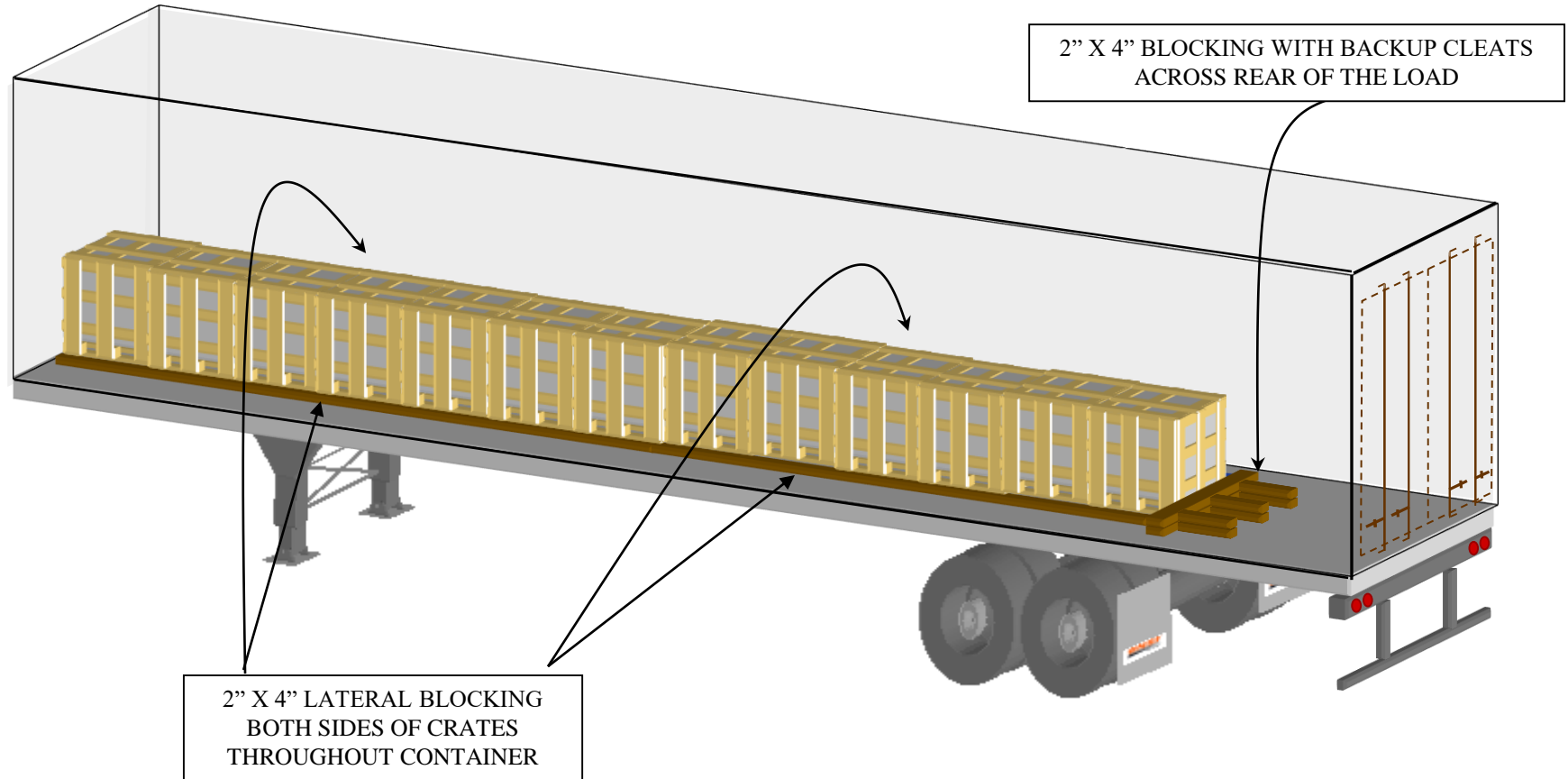
Due to the dense product weight, the pallets of tile are loaded in only one row from nose to rear of trailer/container. It's the shipper's responsibility to maintain proper weight distribution for OTR axle weights.

Wood Floor Blocking/Bracing

The rear of the load is secured with 2"x4" laminated wood floor blocking in order to restrict longitudinal movement. At rear of load, the 2"x4"x6' wood floor blocking is reinforced with three laminated 2"x4"x18" back-up cleats. Wood floor blocking is also utilized to restrict lateral movement. The entire length of both sides of all single row pallets is secured with 2"x4" lumber. All wood floor blocking is secured with 16d nails that are spaced four-six inches apart in a staggered pattern. A staggered nail pattern prevents the nails from splitting the wood.

Laminated Wood Floor Blocking: One piece of lumber is nailed to the equipment floor. A second piece of lumber is nailed on top of the first piece of lumber.

TILE IN CRATES – FLOOR BLOCKING



Palletized Cases of Tile (One to Three Units Wide) Secured with Wood Floor Blocking

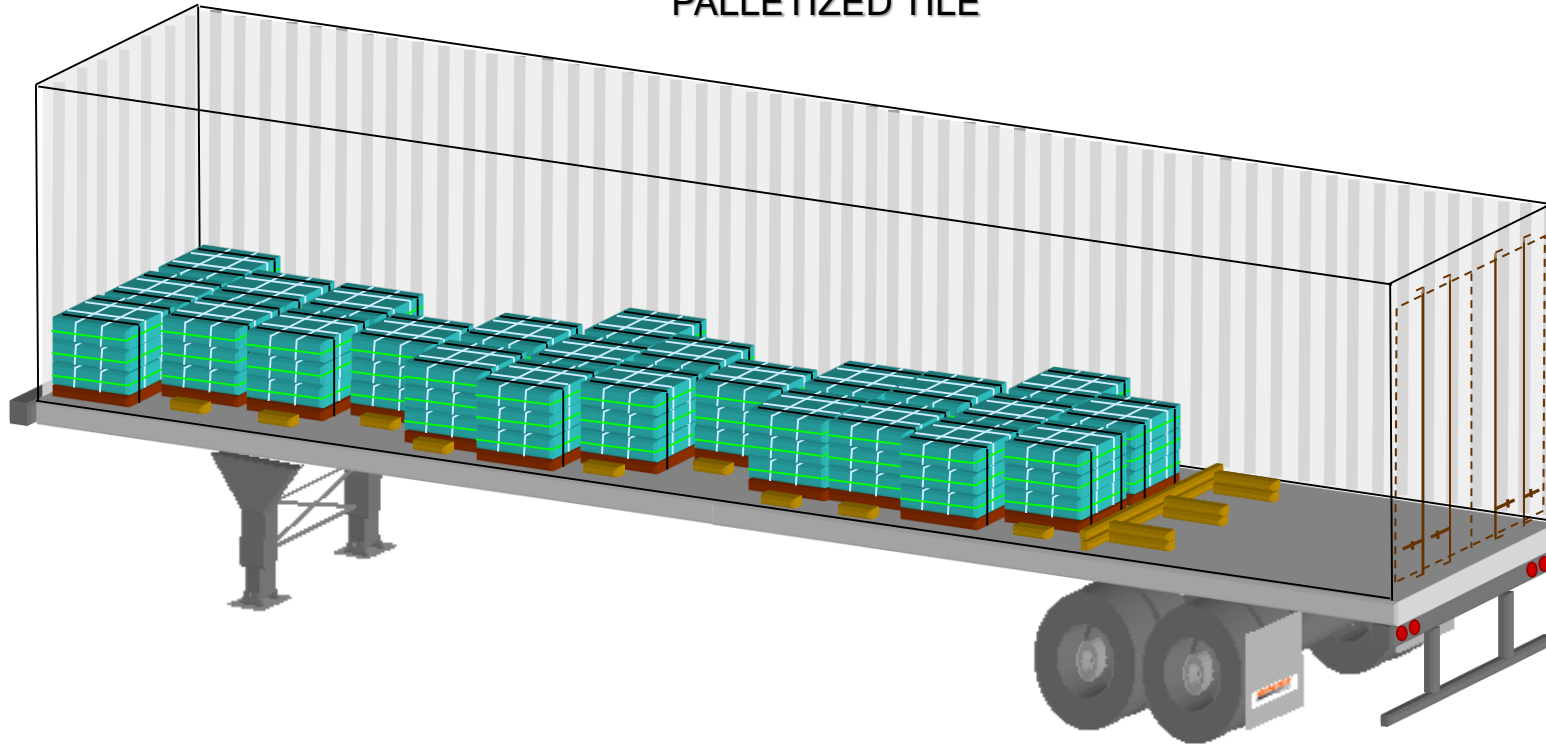
Palletized cases of tile (floor, ceramic, etc.) are unitized with shrink-wrap or stretch-wrap and plastic bands, in accordance with the manufacturer's specifications. Cases are *secured to the pallet* with plastic or steel bands in order to eliminate the risk of product migration (product movement off pallet), which increases the risk of product damage.

Pallets are loaded one-three wide, with any single-wide and double-wide units laterally centered in the trailer or container equipment. These smaller size pallets can be loaded three wide, with minimal lateral void space. Due to dense product weight, the single-wide units help "stretch out the load" and maintain proper weight distribution for OTR axle weights.

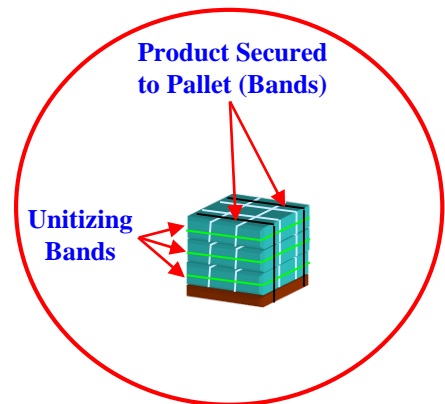
Wood Floor Blocking/Bracing

The rear of the load is secured with 2"x4" wood floor blocking in order to restrict longitudinal movement. At rear of load, the laminated wood floor blocking runs the entire width of the equipment and is reinforced with three laminated 2"x4"x18" back-up cleats. Wood floor blocking is also utilized to restrict lateral movement. One piece of 2"x4"x18" lumber is placed on each side of all single-wide and double-wide pallets. All wood floor blocking is secured with 16d nails that are spaced four-six inches apart in a staggered pattern. A staggered nail pattern prevents the nails from splitting the wood.

Laminated Wood Floor Blocking: One piece of lumber is nailed to the equipment floor. A second piece of lumber is nailed on top of the first piece of lumber.

PALLETIZED TILE**BLOCKING/BRACING OF INTERMODAL SHIPMENT**

- 1.) Boxes of Ceramic Tile Loaded on Pallets. Boxes Unitized with Shrink-Wrap and Plastic Bands. Product Secured to Pallet in Order to Eliminate Risk of Product Migration.
- 2.) The Palletized Product is Loaded One - Three Units Wide. Shipper Responsibility to Provide Proper Weight Distribution in Equipment.
- 3.) Floor Blocking (2"x4" Lumber): Side Blocking for Single-Wide & Double-Wide Units = 2"x4"x18" Secured with Minimum 4 Nails (16d). Rear Blocking = Laminated 2"x4"x8' plus 2"x4"x18" Back-Up Cleats Secured with 16d Nails (Staggered Pattern, Every 4 - 6").



Palletized Cases of Tile (2 - 2 Offset Pattern) Braced with Wood Floor Blocking

Palletized cases of tile (floor, ceramic, etc.) are unitized with shrink-wrap or stretch-wrap and plastic bands, in accordance with the manufacturer's specifications. Cases are *secured to the pallet* with plastic or steel bands in order to eliminate the risk of product migration (product movement off pallet), which increases the risk of product damage.

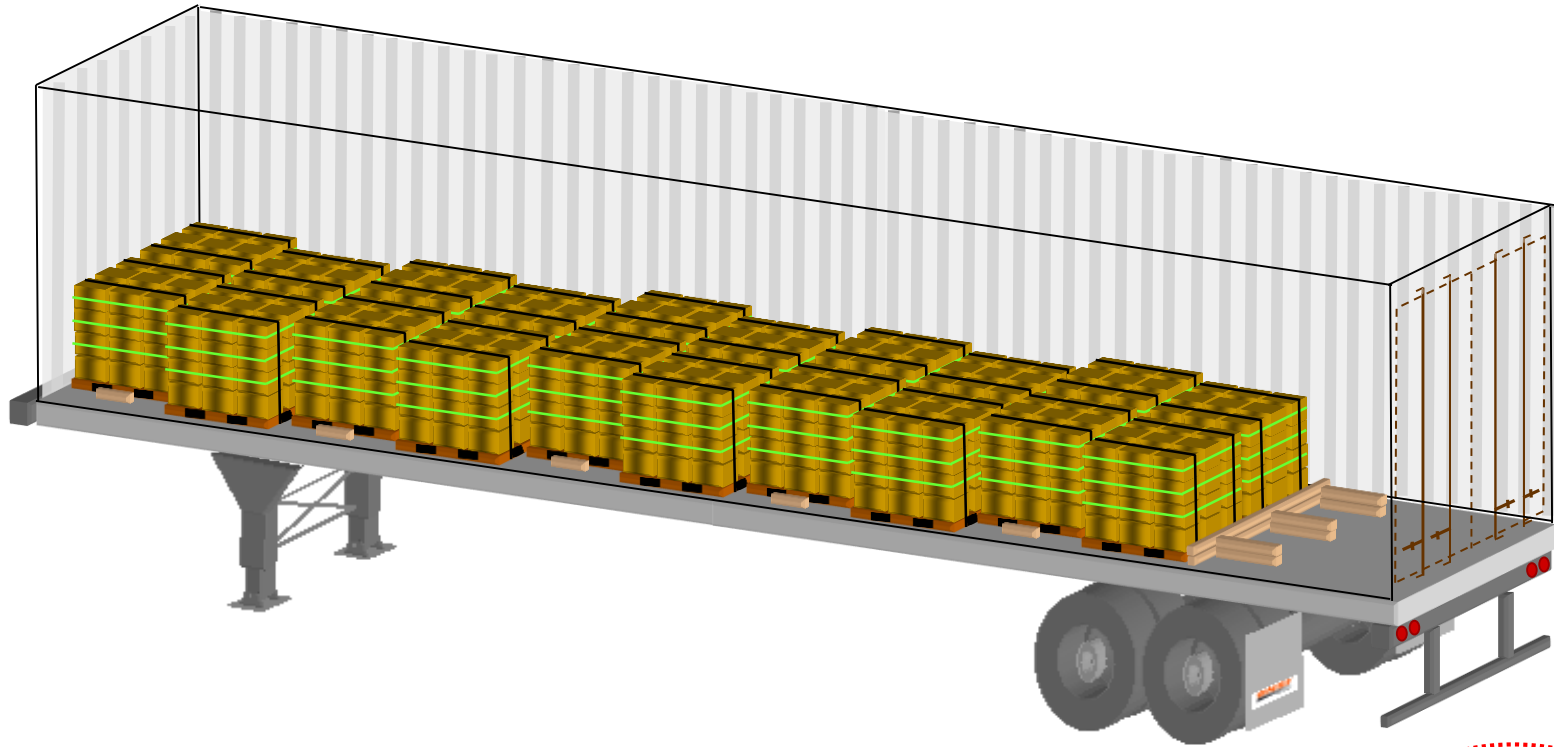
Pallets are loaded in a 2-2 offset pattern. More often than not, pallets of tile are smaller than standard size 40"x48" pallet.

Wood Floor Blocking/Bracing

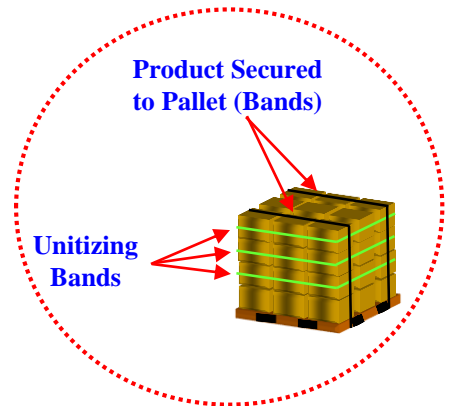
The rear of the load is secured with 2"x4" laminated wood floor blocking in order to restrict longitudinal movement. At rear of load, the wood floor blocking runs the entire width of the equipment and is reinforced with three laminated 2"x4"x18" back-up cleats. One side of each pair of pallets is also secured with 2"x4"x18" wood floor blocking to restrict lateral movement. All wood floor blocking is secured with 16d nails that are spaced four-six inches apart in a staggered pattern. A staggered nail pattern prevents the nails from splitting the wood.

Laminated Wood Floor Blocking: One piece of lumber is nailed to the equipment floor. A second piece of lumber is nailed on top of the first piece of lumber.

PALLETIZED TILE

**BLOCKING/BRACING OF INTERMODAL SHIPMENT**

- 1.) Boxes of Ceramic Tile Loaded on Pallets. Boxes Unitized with Shrink-Wrap and Bands. Product Secured to Pallet in Order to Eliminate Risk of Product Migration.
- 2.) The Palletized Product is Loaded in 2-2 Offset Pattern. Any Single-Wide Units Should be Laterally Centered in the Trailer.
- 3.) Floor Blocking (2"x4" Lumber): Side Blocking = 2"x4"x18" Secured with 4 Nails (16d). Rear Blocking = Laminated 2"x4"x8' plus 2"x4"x18" Back-Up Cleats Secured with 16d Nails (Staggered Pattern, Every 4 - 6"). **Note: Single-Wide Units – 2"x4"x18" Side Blocking on Both Sides.**

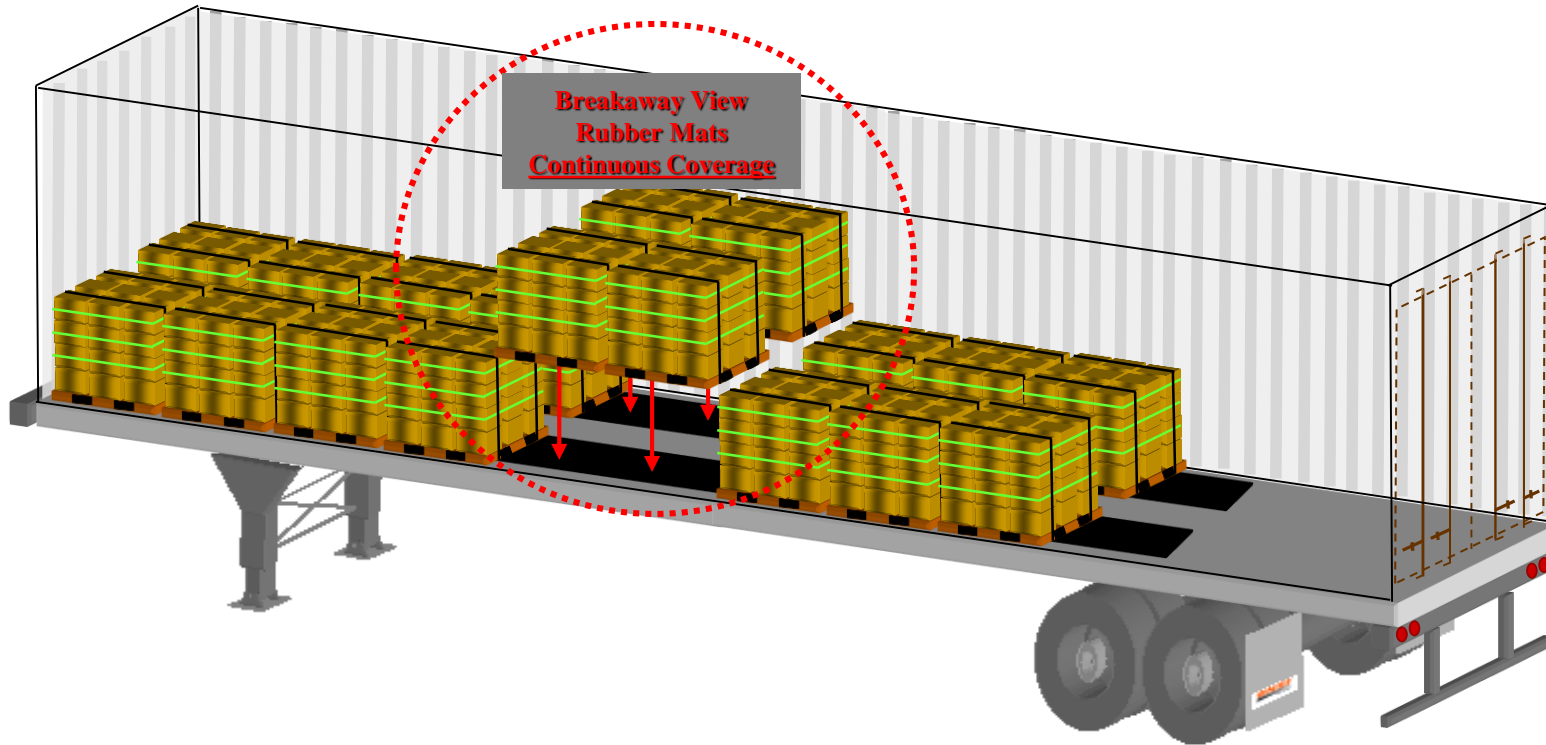


Palletized Cases of Tile (Two Pallets Wide) Secured with Rubber Mats

Palletized cases of tile (floor, ceramic, etc.) are unitized with shrink-wrap or stretch-wrap and plastic bands, in accordance with the manufacturer's specifications. Cases are *secured to the pallet* with plastic or steel bands in order to eliminate the risk of product migration (product movement off pallet), which increases the risk of product damage.

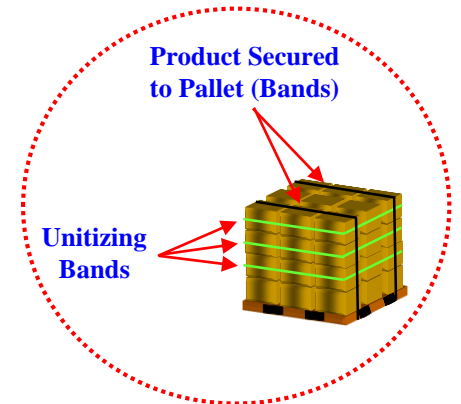
The pallets are loaded in two rows, one adjacent each sidewall of the trailer or container equipment. It's the shipper's responsibility to maintain proper weight distribution for OTR axle weights. The entire load is blocked and braced with two three-foot width (3mm or .0125 thick) rubber mats that provide *continuous floor coverage* from equipment nose to a minimum of six-inches beyond the rear of the load. The rubber matting should be laterally centered underneath the pallets. It is NOT permissible to utilize individual pieces of rubber mats.

PALLETIZED TILE



BLOCKING/BRACING OF INTERMODAL SHIPMENT

- 1.) Boxes of Ceramic Tile Loaded on Pallets. Boxes Unitized with Stretch-Wrap and/or Plastic Bands. When Product is not Secured to Pallet, Product Migration (Product Movement Off Pallet) may Occur.
- 2.) The Palletized Product is Loaded in Two Rows Along Left and Right Sidewalls of the Equipment. The Load is Blocked/Braced with Two 3' Width (3mm or .0125 Thick) Rubber Mats that Provide Continuous Floor Coverage from the Equipment Nose to Minimum of 6" Beyond the Rear of the Load.
- 3.) Shipper Responsibility to Configure Load that Ensures Proper Weight Distribution for OTR Scales.



BULK BLADDER (FLEXI-TANK)



Bulk Bladder (Flexi-Tank) shipments are defined as a “restricted commodity” on BNSF Railway. See BNSF Intermodal Rules and Policies Guide Item 21 and 43.

BULK BLADDER (FLEXI-TANK) SHIPMENTS

Loading Requirements

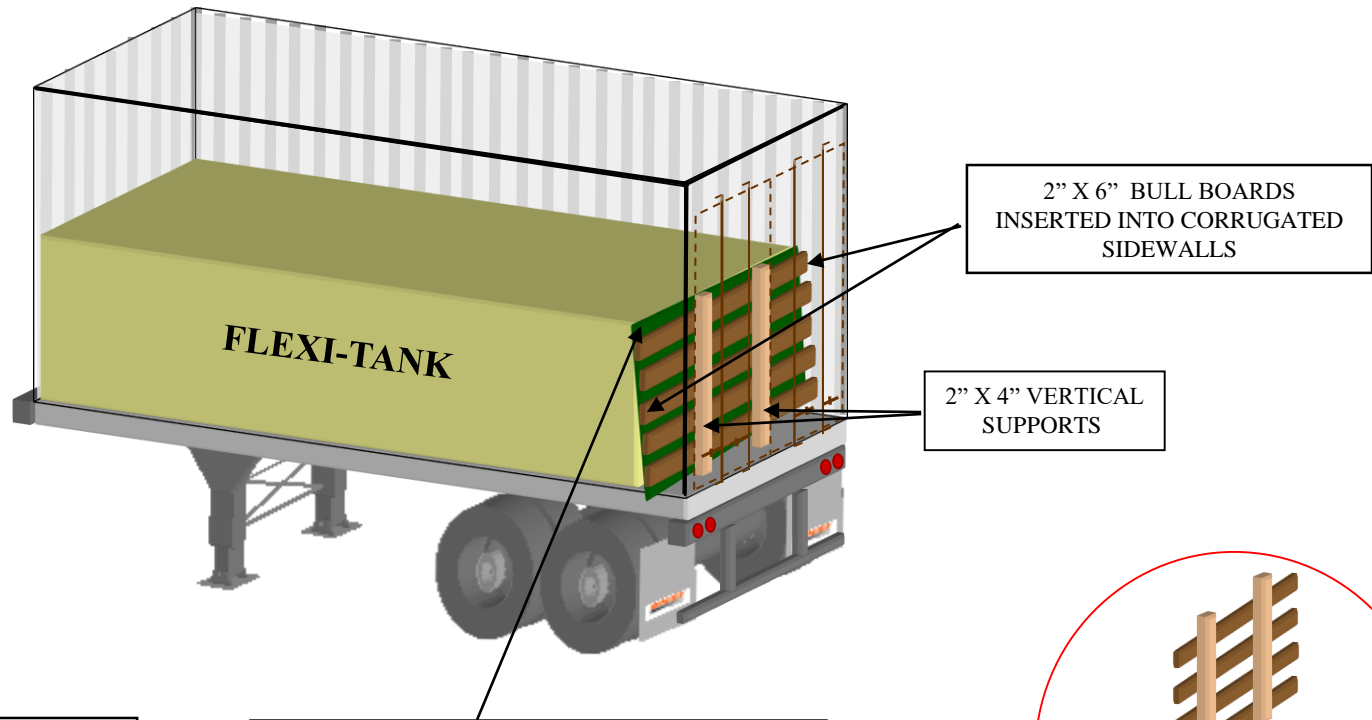
When ordering equipment specify a steel reinforced, standard, twenty foot (20') ISO box container with fully corrugated sides and end. Inspect the exterior of the container, ensure there are no gashes in the side, no rust fractures around the base, check that the doors fit properly, reject if the closing bars are bent or distorted. Make sure the inside of the container is free from rust or physical damage. Sweep the floor and check for nails or sharp edges, etc. Install Flexi-Tank to manufacture specifications. A bulk head must be installed at the rear doors to prevent the Flex-Tank and valve from contacting the containers rear doors. Secure doors properly and seal with minimum 1/8" barrier seal.

Restrictions

Non-hazardous bulk bladder shipments are restricted and must be tendered with a special price authority for this type of shipment. Under no circumstances will the Shipper tender any hazardous materials, substance, waste, or environmentally harmful commodities in bulk bladders. When tendering a non-hazardous bulk bladder shipment, the Shipper must use a suitable bladder (capable of withstanding accelerations, decelerations, forces, and vibrations in the railroad environment) for the commodity. The Shipper is fully responsible for utilizing equipment in a condition adequate to withstand pressures that will be exerted on the bladder, regardless of cause. When tendering non-hazardous bulk bladder shipments, the Shipper is fully responsible for using private equipment that is not greater than ten (10) years old, is in suitable condition to carry concentrated weights, has no visible defects, and meets or exceeds AAR M-930 or M-931 specifications.



LOADING METHOD FOR FLEXI-TANKS IN 20' STEAMSHIP CONTAINERS WITH WOOD BULL BOARDS



LOAD RESTRAINING CAPACITY	
RESTRAINT DEVICE	CAPACITY
2" X 4" BULL BOARD	5,600 LBS
2" X 6" BULL BOARD	8,000 LBS
2" X 4" "T" BRACE	7,000 LBS

PLYWOOD OR FIBERBOARD FILLER
 (DENOTED BY GREEN COLOR) BETWEEN
 FLEXI-TANK AND BULL BOARDS



FLEXI-TANK DOORWAY SECUREMENT MUST NOT COME IN CONTACT WITH CONTAINERS DOORS

LUMBER & PLYWOOD PRODUCTS



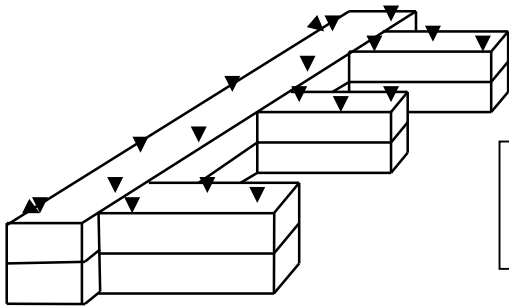
Dimensional Lumber Secured by Wood Floor Blocking

Unitized dimensional lumber loaded longitudinal, two wide, alternately stowed along the container sidewalls for intermodal service. Cargo is loaded from the front endwall, product-to-product contact without any longitudinal voids.

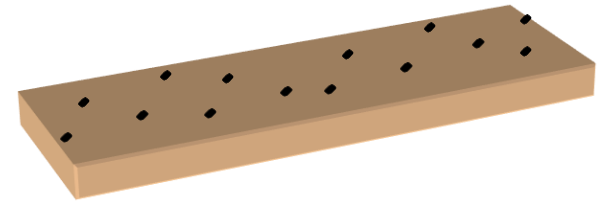
Stacks 8' in length or less must have minimum 2 – 5/8" packaging bands approximately two feet from each end, lengths longer than 8' must have minimum of 3 – 5/8" packaging bands of sufficient strength equally spaced (bands should be approximately four feet apart).

For units 8' in length or shorter, apply 2" x 6" x 36" side blocking to center of unit on side with lateral void.
For units 10' or longer, apply 2" x 6" x 24" side blocking on each end of unit on side with lateral void.

Floor blocking in doorway consists of 2 - 2" x 6" laminated boards (equal to width of lading) with 3 - 2" x 6" x 18" laminated back-up cleats.



LAMINATED 2" x 6" x (WIDTH)
FLOOR BLOCKING and 2" x 6" x 18"
BACK-UP CLEATS (REAR OF LOAD)

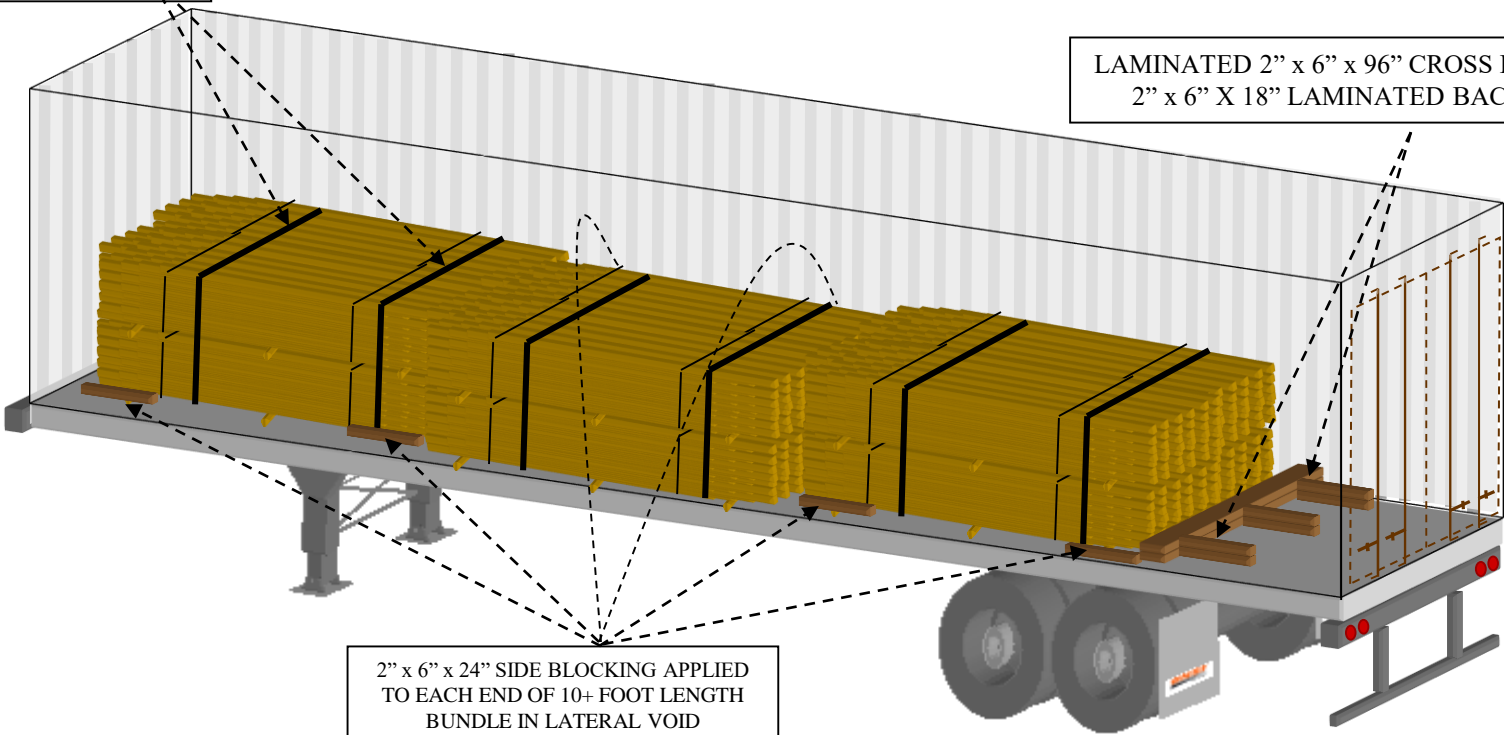


FLOOR BLOCKING SHOULD BE SECURELY NAILED TO THE TRAILER FLOOR AND MUST PENETRATE THE TRAILER FLOOR TO A DEPTH OF 1" OR MORE. THE NAILS SHOULD BE APPLIED IN A STAGGERED PATTERN, 4-6" APART.

UNITIZED STACKS OF LUMBER STOWED LONGITUDINAL

2 - 1 1/4" X .031 STEEL
UNITIZING BANDS
PER STACK

LAMINATED 2" x 6" x 96" CROSS BLOCKING WITH
2" x 6" X 18" LAMINATED BACK-UP CLEATS



2" x 6" x 24" SIDE BLOCKING APPLIED
TO EACH END OF 10+ FOOT LENGTH
BUNDLE IN LATERAL VOID

ALTERNATIVE
2" x 6" x 36" SIDE BLOCKING APPLIED
TO CENTER OF 8 FOOT LENGTH OR
LESS BUNDLE IN LATERAL VOID

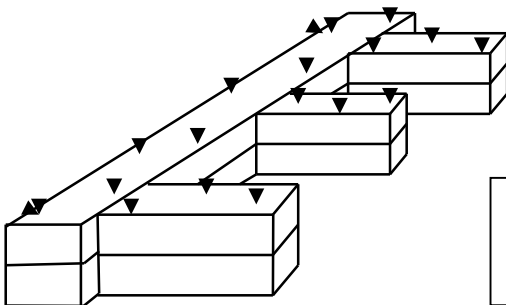
Dimensional Lumber Secured by Wood Floor Blocking and D. I. D. Airbags

Unitized dimensional lumber loaded longitudinal in two rows along the container sidewalls for intermodal service. Cargo is loaded from the front endwall, product-to-product contact without any longitudinal voids.

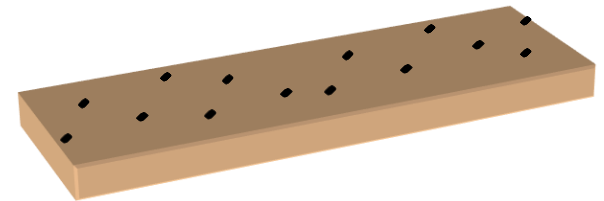
Stacks 8' in length or less must have minimum 2 – 5/8" packaging bands approximately two feet from each end, lengths longer than 8' must have minimum of 3 – 5/8" packaging bands of sufficient strength equally spaced (bands should be approximately four feet apart).

Install D. I. D. bags (Level 1- 48" x height of load) in centerline void to maintain lateral alignment of the cargo, one bag per stack. Fiberboard sheets must be placed on each side of D.I.D. bags to prevent airbag from rubbing against the cargo. Centerline void filled by D. I. D. bags is not to exceed 12". Airbags to be position a minimum of 1" above floor with bag inflation not to exceed 2 psi.

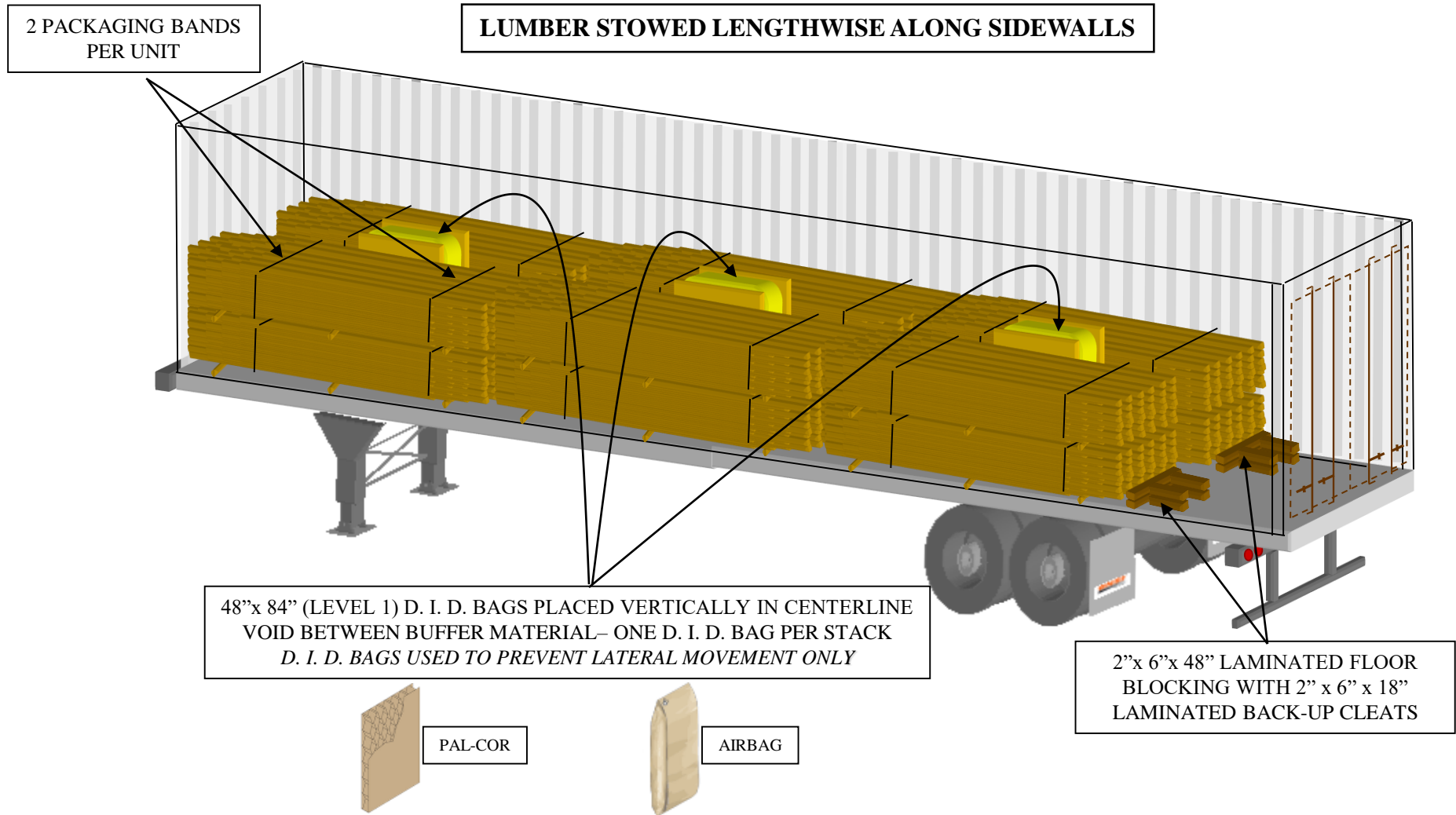
The floor blocking at the doorway at the end of each row of lumber consists of 2 - 2" x 6" x 48" laminated boards with 2 - 2" x 6" x 18" laminated back-up cleats.



LAMINATED 2" x 6" x (WIDTH)
FLOOR BLOCKING and 2" x 6" x 18"
BACK-UP CLEATS (REAR OF LOAD)



FLOOR BLOCKING SHOULD BE SECURELY NAILED TO THE TRAILER FLOOR AND MUST PENETRATE THE TRAILER FLOOR TO A DEPTH OF 1" OR MORE. THE NAILS SHOULD BE APPLIED IN A STAGGERED PATTERN, 4-6" APART.



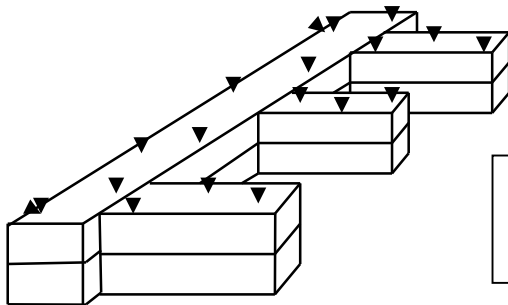
NAILS USED TO SECURE FLOOR BLOCKING MUST BE 16D OR LARGER AND PLACED EVERY 4 - 6" IN AN OFFSET PATTERN

Plywood Secured by Wood Floor Blocking and Steel Bands

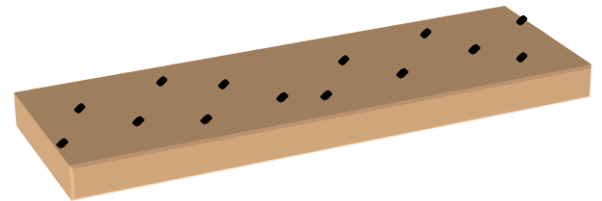
This loading and securement is for unitized 4' x 8' bundles of plywood stowed laterally, unitized with steel straps and laminated floor blocking. Each bundle of plywood is secured with 2 – 5/8" packaging bands. All units stacked two high are to be unitized with two 1 1/4" x .031 steel encircling straps.

Prepare container by positioning two steel straps on the floor of container 24" from each sidewall of sufficient length to encircle all double-stacked units with continuous banding. Tape steel bands along sidewalls to facilitate loading. Plywood units are loaded from the front endwall, product-to-product contact without any longitudinal voids, alternately stowed along the container sidewalls on top of the steel bands. Upon loading double-stacked units, position unitizing straps over the top of the load, tighten with tensioning device, and secure with two seals with a minimum of four crimps each. Metal or fiberboard corner protection is recommended to protect the product from the steel strapping.

Load single units in doorway tightly against double stacked units. Apply 2 – 2" x 6" x 96" laminated floor blocking with 3 - 2" x 6" x 18" laminated back-up cleats against last stack in doorway.

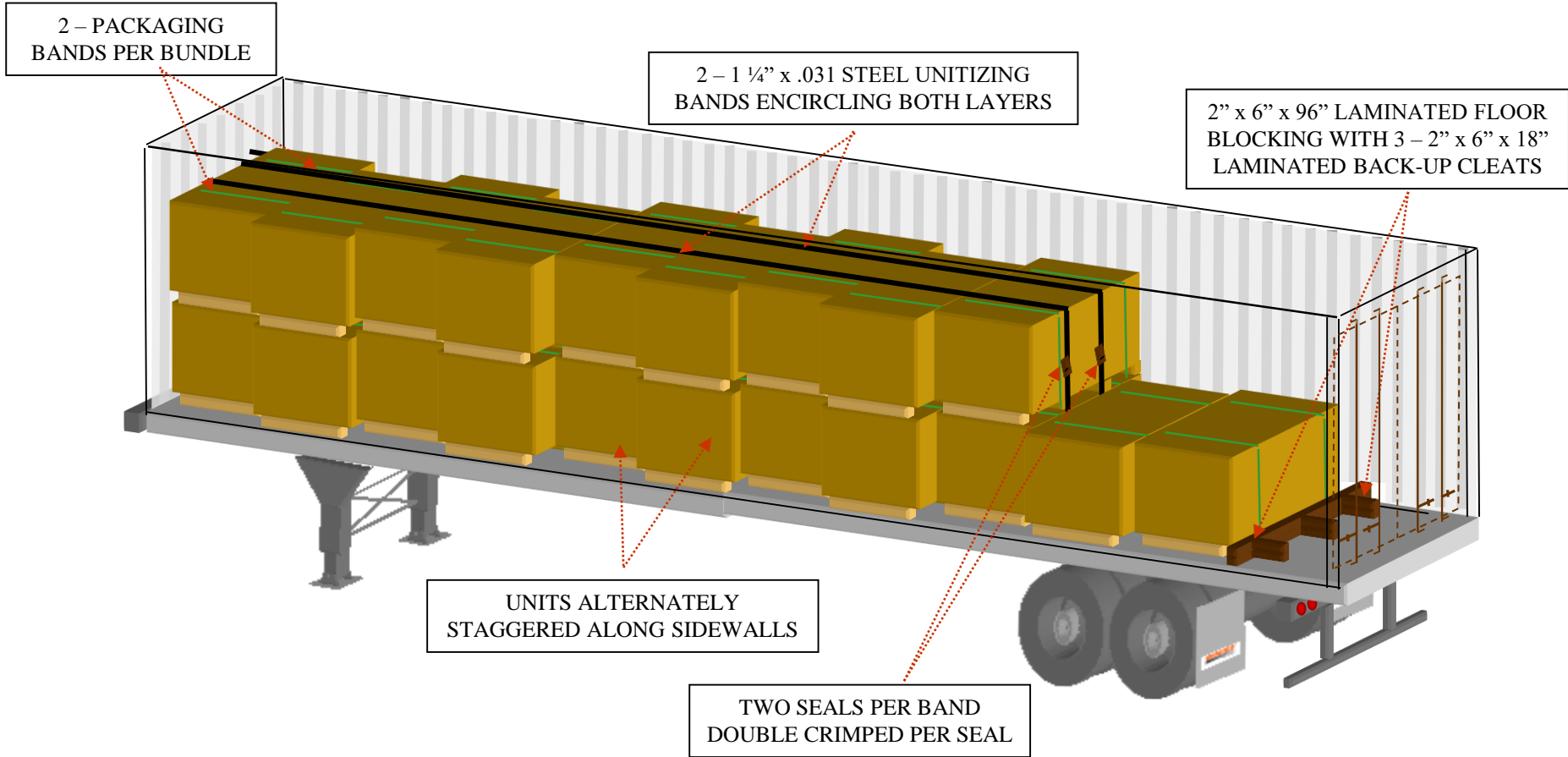


LAMINATED 2" x 6" x (WIDTH)
FLOOR BLOCKING and 2" x 6" x 18"
BACK-UP CLEATS (REAR OF LOAD)



FLOOR BLOCKING SHOULD BE SECURELY NAILED TO THE TRAILER FLOOR AND MUST PENETRATE THE TRAILER FLOOR TO A DEPTH OF 1" OR MORE. THE NAILS SHOULD BE APPLIED IN A STAGGERED PATTERN, 4-6" APART.

UNITIZED (48" x 96" WIDTH) PLYWOOD BUNDLES STOWED LATERAL

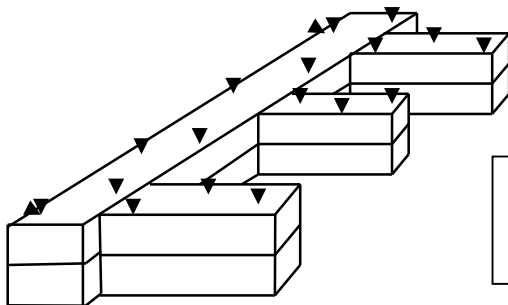


Plywood – Incomplete Second Layer Secured by Wood Floor Blocking & Steel Bands

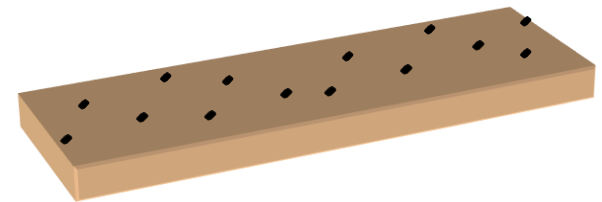
This loading and securement is for unitized 4' x 8' bundles of plywood stowed laterally, unitized with steel straps and laminated floor blocking. Each bundle of plywood is secured with 2 – 5/8" packaging bands. All units stacked two high are to be unitized with 2 – 1 1/4" x .031 steel encircling straps.

Load single-layer units from the front endwall, alternately staggered along the sidewalls. Prepare container for unitized units by positioning two steel straps on the floor of container 24" from each sidewall, of sufficient length to encircle all double-stacked units with continuous banding. Tape steel bands along sidewalls to facilitate loading. Plywood units are loaded from the front endwall, product-to-product contact without any longitudinal voids, alternately stowed along the container sidewalls on top of the steel bands. Upon loading double-stacked units, position unitizing straps over the top of the load, tighten with tensioning device, and secure with two seals with a minimum of four crimps each. Metal or fiberboard corner protection is recommended to protect the product from the steel strapping.

Load remainder of single units in doorway area tightly against adjacent units. Apply 2 – 2" x 6" x 96" laminated floor blocking with 3 - 2" x 6" x 18" laminated back-up cleats against last stack in doorway.

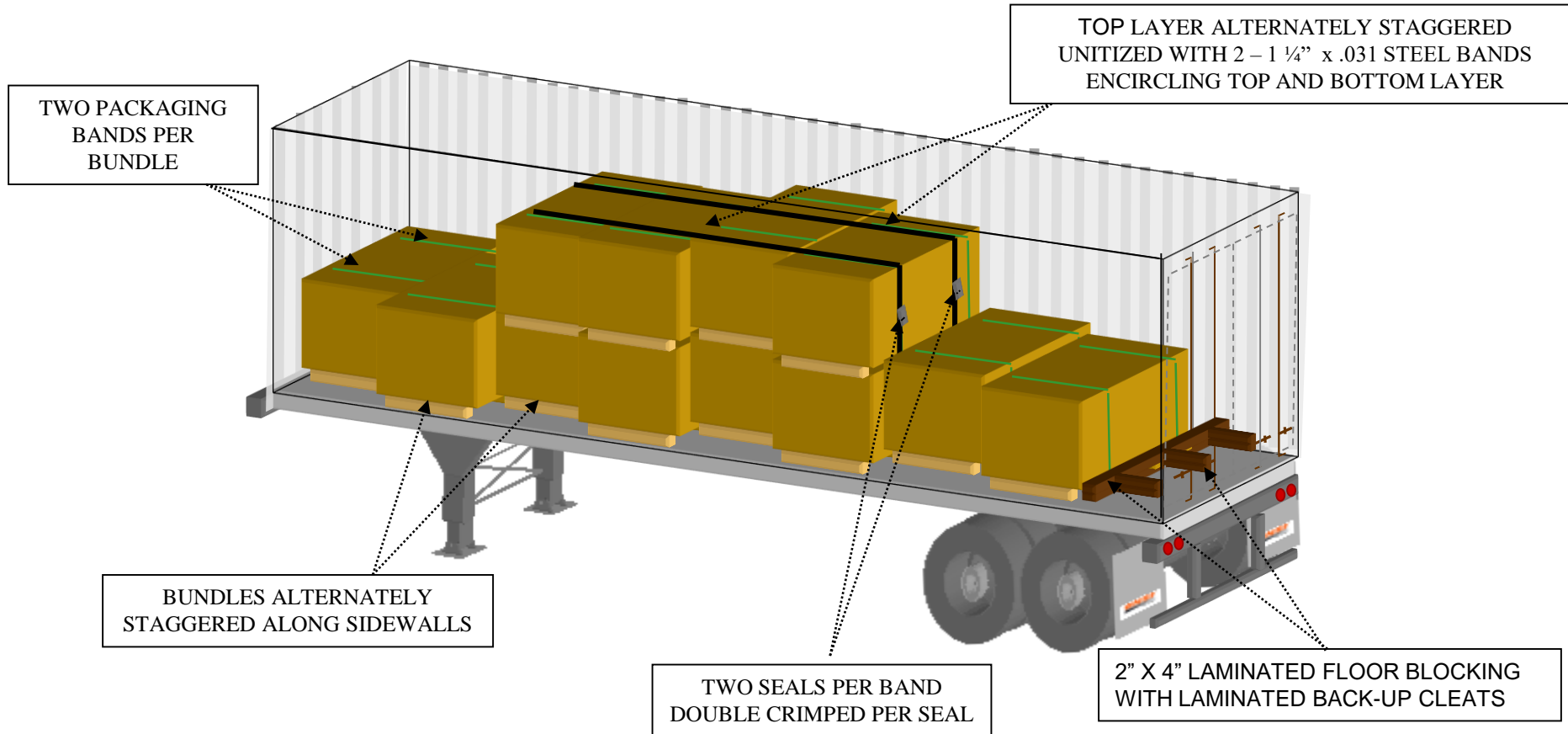


LAMINATED 2" x 6" x (WIDTH)
FLOOR BLOCKING and 2" x 6" x 18"
BACK-UP CLEATS (REAR OF LOAD)



FLOOR BLOCKING SHOULD BE SECURELY NAILED TO THE TRAILER FLOOR AND MUST PENETRATE THE TRAILER FLOOR TO A DEPTH OF 1" OR MORE. THE NAILS SHOULD BE APPLIED IN A STAGGERED PATTERN, 4-6" APART.

PLYWOOD (48" x 96" WIDTH) STOWED Laterally WITH INCOMPLETE SECOND LAYER



Lumber Loaded Laterally in 20' Container Equipment Secured With Bullboards

Unitized dimensional lumber loaded laterally, units of equal heights, alternately staggered along the container sidewalls. Cargo is loaded from the front endwall, product-to-product contact without any longitudinal voids.

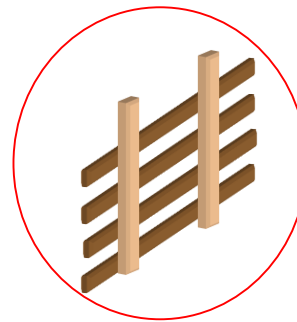
Stacks 8' in length or less must have minimum 2 – 5/8" packaging bands approximately two feet from each end, lengths longer than 8' must have minimum of 3 – 5/8" packaging bands of sufficient strength equally spaced (bands should be approximately four feet apart).

Each row alternately placed against sidewall starting from the nosewall to the doors. Cargo secured with 2x4 or 2x6 bullboards inserted into the slotted doorposts or in the corrugated sidewalls. Two vertical 2x4's are secured to the horizontal bullboards to prevent displacement and to add support.

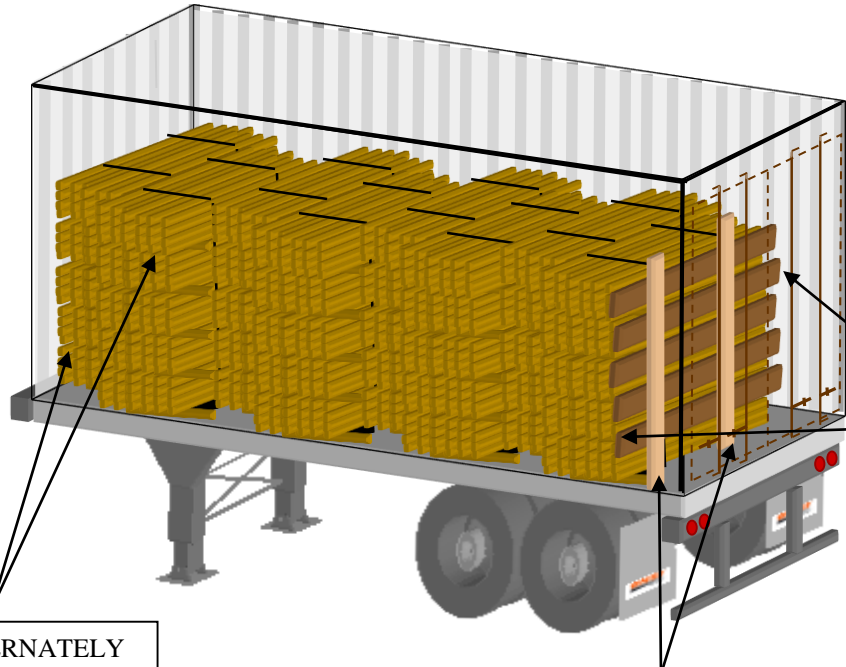
Optional: plywood buffer material can be placed between the cargo and bullboards to help evenly distribute cargo forces (not shown in diagram).

Miter corners of bullboards to simplify dropping of bullboards into slotted doorposts.

LOAD RESTRAINING CAPACITY	
RESTRAINT DEVICE	CAPACITY
2" X 4" BULLBOARD BOARD	5,600 LBS
2" X 6" BULLBOARD BOARD	8,000 LBS
2" X 4" "T" BRACE	7,000 LBS



LUMBER IN 20' STEAMSHIP CONTAINER STOWED LATERAL SECURED WITH BULL BOARDS



LOAD RESTRAINING CAPACITY	
RESTRAINT DEVICE	CAPACITY
2" X 4" BULL BOARD	5,600 LBS
2" X 6" BULL BOARD	8,000 LBS
2" X 4" "T" BRACE	7,000 LBS

UNITS ALTERNATELY
STAGGERED ALONG
SIDEWALLS

VERTICAL 2"X4" LUMBER IS SECURED TO THE
HORIZONTAL BULL BOARDS IN ORDER TO
PREVENT DISPLACEMENT

2" x 6" BULL BOARDS IN
CORRUGATED CONTAINER
SIDEWALLS

SUPER SACKS



Palletized Super Sacks (2 - 2 Offset Pattern) – Secured with D.I.D. Bags

Palletized super sacks secured to pallet with either stretch-wrap (including base of pallet) in accordance with the manufacturer's specifications or 1/2" to 7/16" plastic bands properly tightened with a tensioning strapping device, or a combination of both.

D.I.D. bags must be a minimum of 48" x 96" (Level 1) placed horizontally in centerline void. Two D.I.D. bags are utilized for load securement; the first is placed in the center of the load and the second at the rear of the load. NOTE! For this loading method to be effective, minimal air space must exist within the super sack product. When excessive air space exists, the force exerted by the D.I.D. bag against the super sack product easily displaces the product within the bag, which reduces the effectiveness of the bag.

Pallets are loaded in a 2-2 offset pattern. The pallet's 48" dimension is loaded lateral in 100-102" width equipment and the 40" dimension is loaded lateral in 96-98" width equipment. Note: Loaded lateral = perpendicular to equipment sidewalls. The load plan should minimize lateral void space. Except at D.I.D. bag locations (100-102" width equipment), it's permissible to load the 48" dimension longitudinal in order to "stretch out the load" and maintain proper OTR axle weights.

When product underhang of the pallet exists it's possible for the product to migrate/move on the pallet, which has the potential to cause product damage. Product underhang of the pallet is considered void space and should be filled with recommended dunnage material.

Disposable Inflatable Dunnage (D.I.D.) Bag – Notes

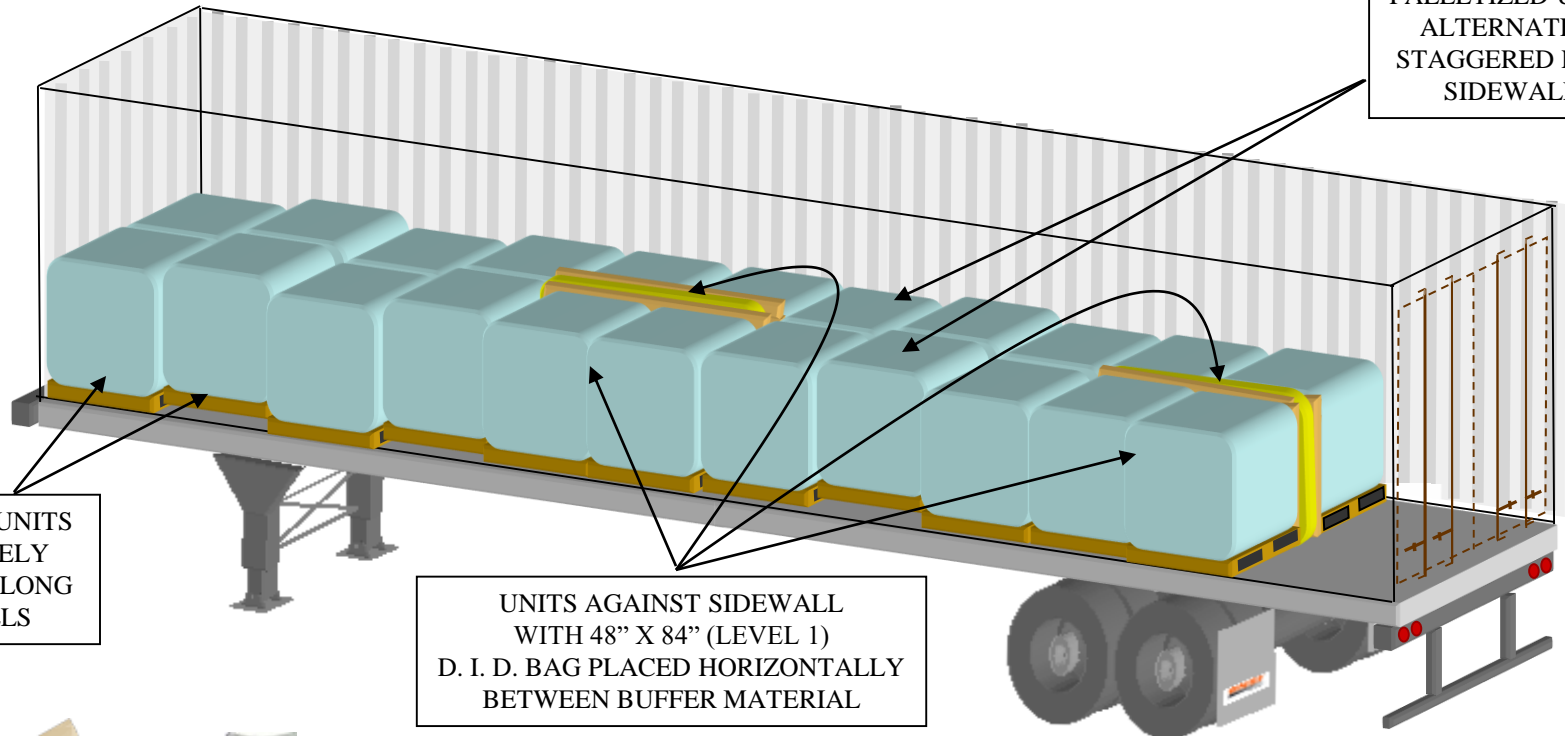
The D.I.D. bag must not be used in a void space in excess of 12" wide. If the void space exceeds 12" width, additional full size void fillers must be placed along side the D.I.D. bag.

After inflation, the D.I.D. bag should be located approximately 4" above the equipment floor. The D.I.D. bag must be adequately buffered to prevent contact with sharp or rough edges that may puncture the bag and inflated to manufacture specifications.

Leave approximately 36" space between the rear of the load and the equipment doors.

PALLETIZED SUPER SACKS STOWED IN 2-2 OFFSET PATTERN SECURED WITH D. I. D. BAGS

**PALLETIZED UNITS
ALTERNATELY
STAGGERED LONG
SIDEWALLS**



**PALLETIZED UNITS
ALTERNATELY
STAGGERED LONG
SIDEWALLS**

**UNITS AGAINST SIDEWALL
WITH 48" X 84" (LEVEL 1)
D. I. D. BAG PLACED HORIZONTALLY
BETWEEN BUFFER MATERIAL**

PAPER



OR



POLYVINYL

**D. I. D. BAG PLACED IN 12" VOID OR LESS, 1" OFF OF FLOOR, BUFFERED FROM PALLETS, INFLATED TO MANUFACTURE SPECIFICATIONS,
TAPE OR TIE OFF D. I. D. BAGS TO PREVENT DISPLACEMENT OF THE BAGS**

Palletized Super Sacks (2 - 2 Offset Pattern) – Secured with Bull Boards

Palletized super sacks secured to pallet with either stretch-wrap (including base of pallet) in accordance with the manufacturer’s specifications or with 1/2” to 7/16” plastic bands properly tighten with a tensioning strapping device, or a combination of both.

Pallets are loaded in a 2-2 offset pattern from the nose to the doorway, except for the last two stacks (four pallets), which are stowed against the sidewalls as illustrated in diagram.

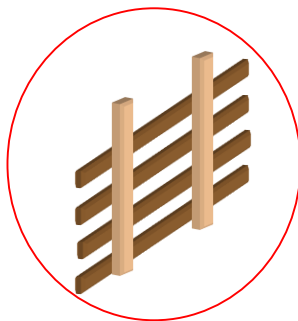
The pallet’s 48” dimension is loaded lateral in 100-102” width equipment and the 40” dimension is loaded lateral in 96-98” width equipment. Note: Loaded lateral = perpendicular to equipment sidewalls. It’s permissible to load the 48” dimension longitudinal in order to “stretch out the load” and maintain proper OTR axle weights.

The cargo is secured with 2x4 or 2x6 bull boards inserted into the slotted doorposts or in the corrugated sidewalls. Two vertical 2x4’s are secured to the horizontal bull boards to prevent displacement and to add support. Miter corners of bull boards to simplify dropping of bullboards into slotted doorposts.

4’ x 8’ x 1/4” plywood or combination wood/honeycomb core divider panels (3/4” thick) buffer is placed between the cargo and bull boards to help evenly distribute lading forces.

Bull Board Application

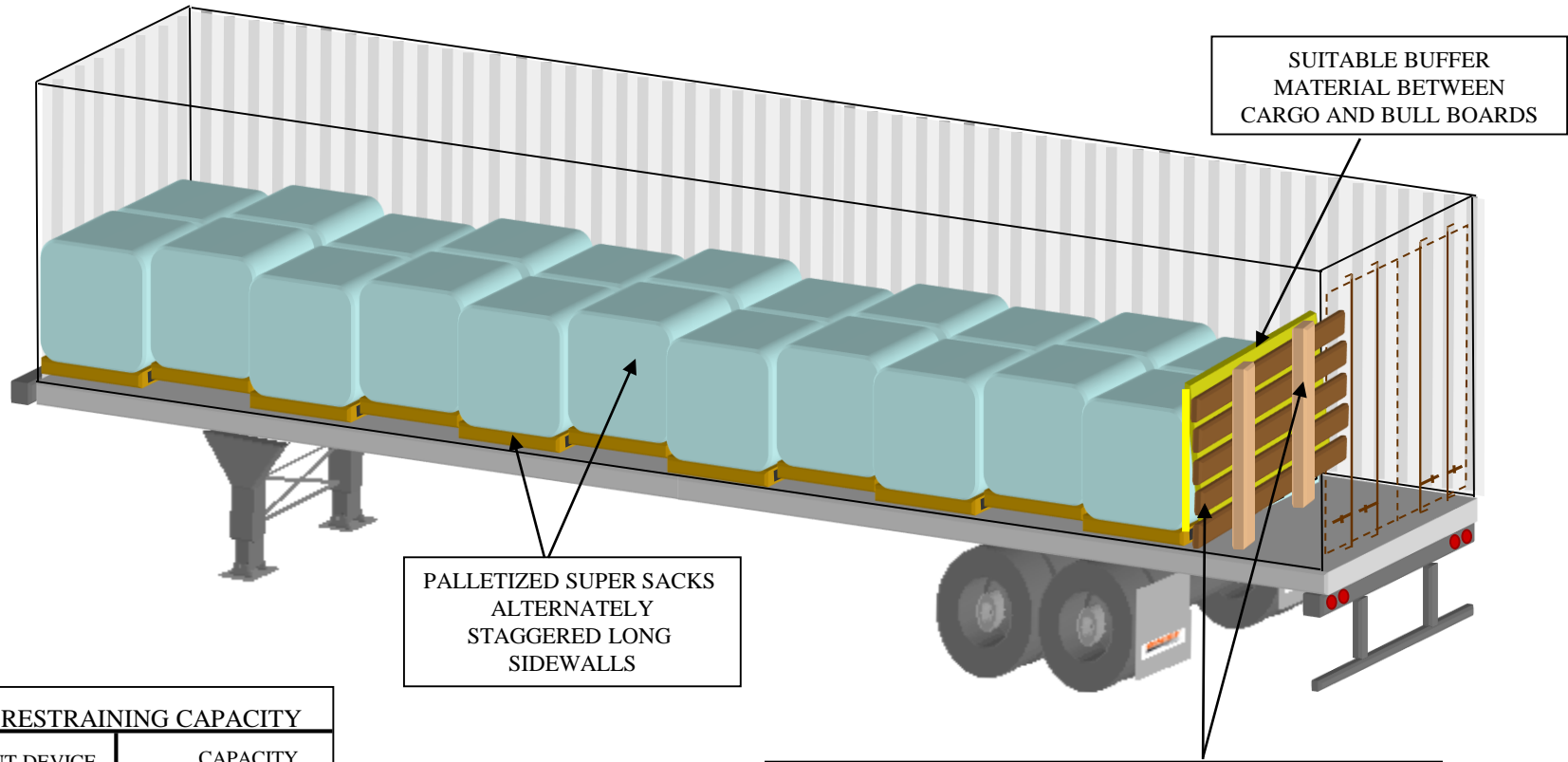
LOAD RESTRAINING CAPACITY	
RESTRAINT DEVICE	CAPACITY
2” X 4” BULLBOARD BOARD	5,600 LBS
2” X 6” BULLBOARD BOARD	8,000 LBS
2” X 4” “T” BRACE	7,000 LBS



**OPTIONAL: PLYWOOD BUFFER MATERIAL
CAN BE PLACED BETWEEN CARGO AND
BULL BOARDS TO HELP EVENLY
DISTRIBUTE CARGO FORCES (NOT SHOWN
IN DIAGRAM)**



PALLETIZED SUPER SACKS STOWED IN 2 -2 OFFSET PATTERN SECURED WITH BULL BOARDS



PALLETIZED SUPER SACKS
ALTERNATELY
STAGGERED LONG
SIDEWALLS

SUITABLE BUFFER
MATERIAL BETWEEN
CARGO AND BULL BOARDS

FIVE - 2" X 6" BULL BOARDS (WITH 2" X 4" VERTICAL
SUPPORTS) MOUNTED IN CORRUGATED CONTAINER
SIDE WALLS OR IN DOORWAY INSET CLIPS

LOAD RESTRAINING CAPACITY	
RESTRAINT DEVICE	CAPACITY
2" X 4" BULL BOARD	5,600 LBS
2" X 6" BULL BOARD	8,000 LBS
2" X 4" "T" BRACE	7,000 LBS

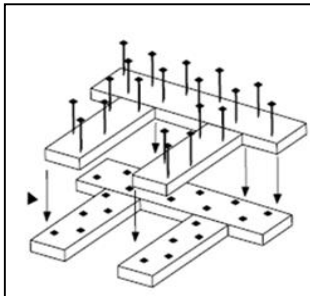
Palletized Super Sacks (2 - 2 Offset Pattern with Single Units) Secured with Laminated Floor Blocking

Palletized super sacks secured to pallet with either stretch-wrap (including base of pallet) in accordance with the manufacturer's specifications or with 1/2" to 7/16" plastic bands properly tighten with a tensioning strapping device, or a combination of both.

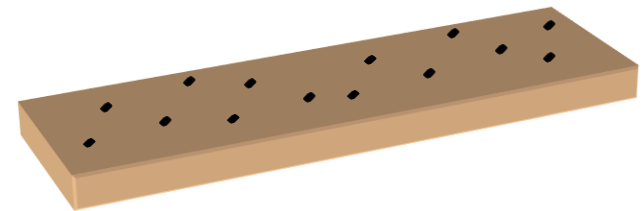
Units are loaded two wide with the 48" dimension longitudinally in order to "stretch out the load" and maintain proper OTR axle weights. All single units are centered and spread out throughout the load (do not place singles back-to-back). Two wide pallets are loaded in a 2-2 offset pattern from the nose to the doorway, except for the last stack (two pallets), which is stowed against the sidewalls as illustrated in diagram.

Apply 2"x 6" x 24" side blocking to each side of single units as illustrated.

Apply 2 - 2" x 6" x 96" laminated floor blocking with 3 - 2" x 6" x 18" laminated back-up cleats against last stack in doorway.



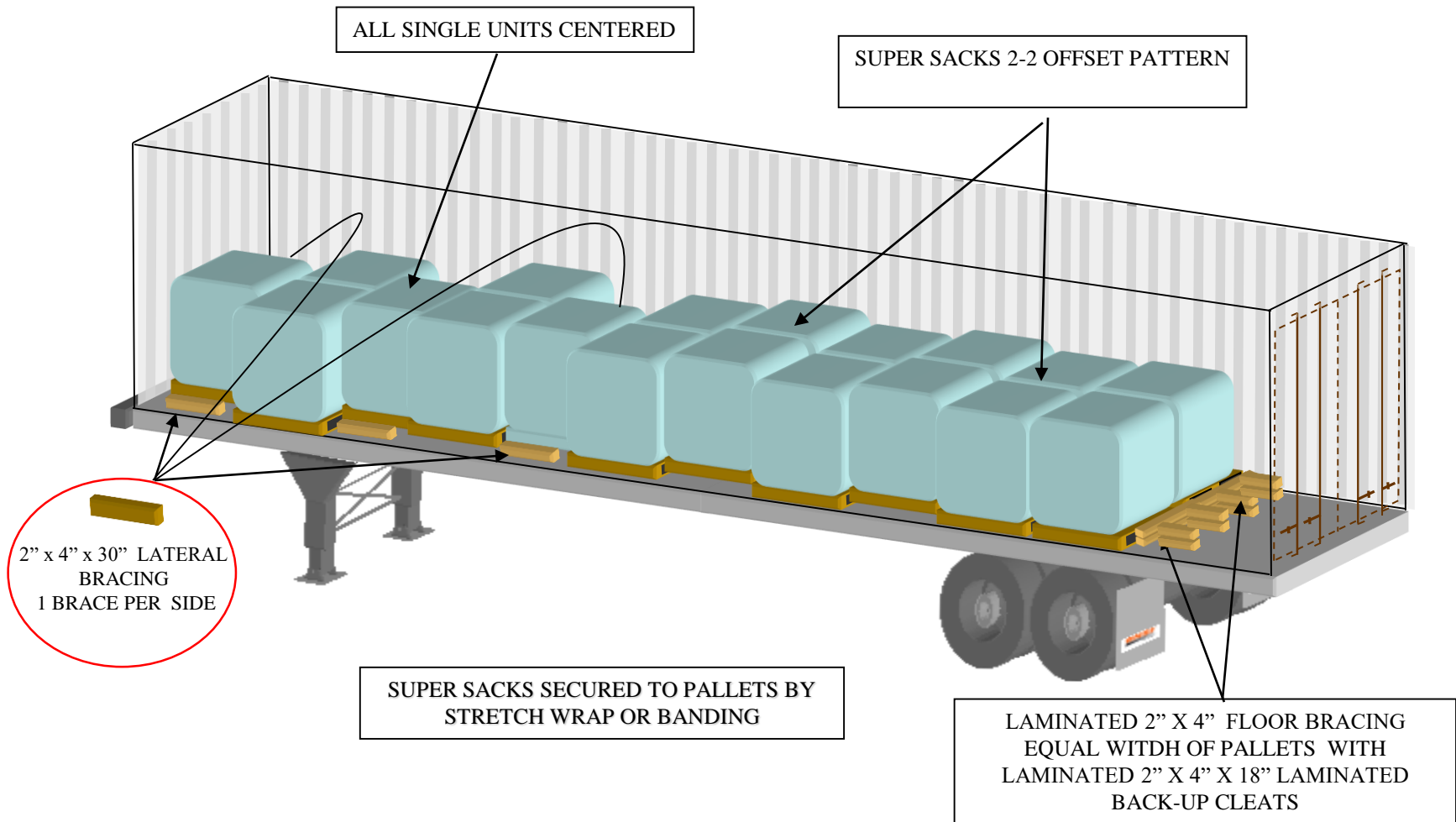
**LAMINATED 2" X 6" X 96" FLOOR
BLOCKING AND 2" X 6" X 18"
BACK-UP CLEATS (REAR OF
LOAD)**



Floor blocking should be securely nailed to the trailer floor and must penetrate the trailer floor to a depth of 1" or more. The nails should be applied in a staggered pattern, 4-6" apart. One 16d nail has approximately holding power of 1,000 lbs., use adequate number of nails for the weight involved.

Leave a minimum of 24" space between the rear of the load and the container doors.

PALLETIZED SUPER SACKS STOWED IN 2-2 OFFSET PATTERN WITH SINGLE UNITS SECURED WITH LAMINATED FLOOR BLOCKING



Palletized Super Sacks (2 - 2 Offset Pattern) – Secured with TY-GARD™ / TY-PATCH™

Palletized super sacks secured to pallet with either stretch-wrap (including base of pallet) in accordance with the manufacturer's specifications or with 1/2" to 7/16" plastic bands properly tighten with a tensioning strapping device, or a combination of both.

Pallets are loaded in a 2-2 offset pattern except for the units where Ty-Gard / Ty-Patch is to be applied. These units must be stowed against sidewalls as illustrated in diagram.

The pallet's 48" dimension is loaded lateral in 100-102" width equipment and the 40" dimension is loaded lateral in 96-98" width equipment. Note: Loaded lateral = perpendicular to equipment sidewalls. It's permissible to load the 48" dimension longitudinal in order to "stretch out the load" and maintain proper OTR axle weights.

The load is divided into two sections. Each section is to contain approximately the same weight. Each floor section is secured with two 15" wide strips of Ty-Gard or Ty-Patch with a 4' x 8' x 1/4" plywood or combination wood/honeycomb core divider panels (3/4" thick) buffer between the lading and Ty-Gard / Ty-Patch, to prevent units from being pulled into the center of the container.

Ty-Gard / Ty-Patch Notes

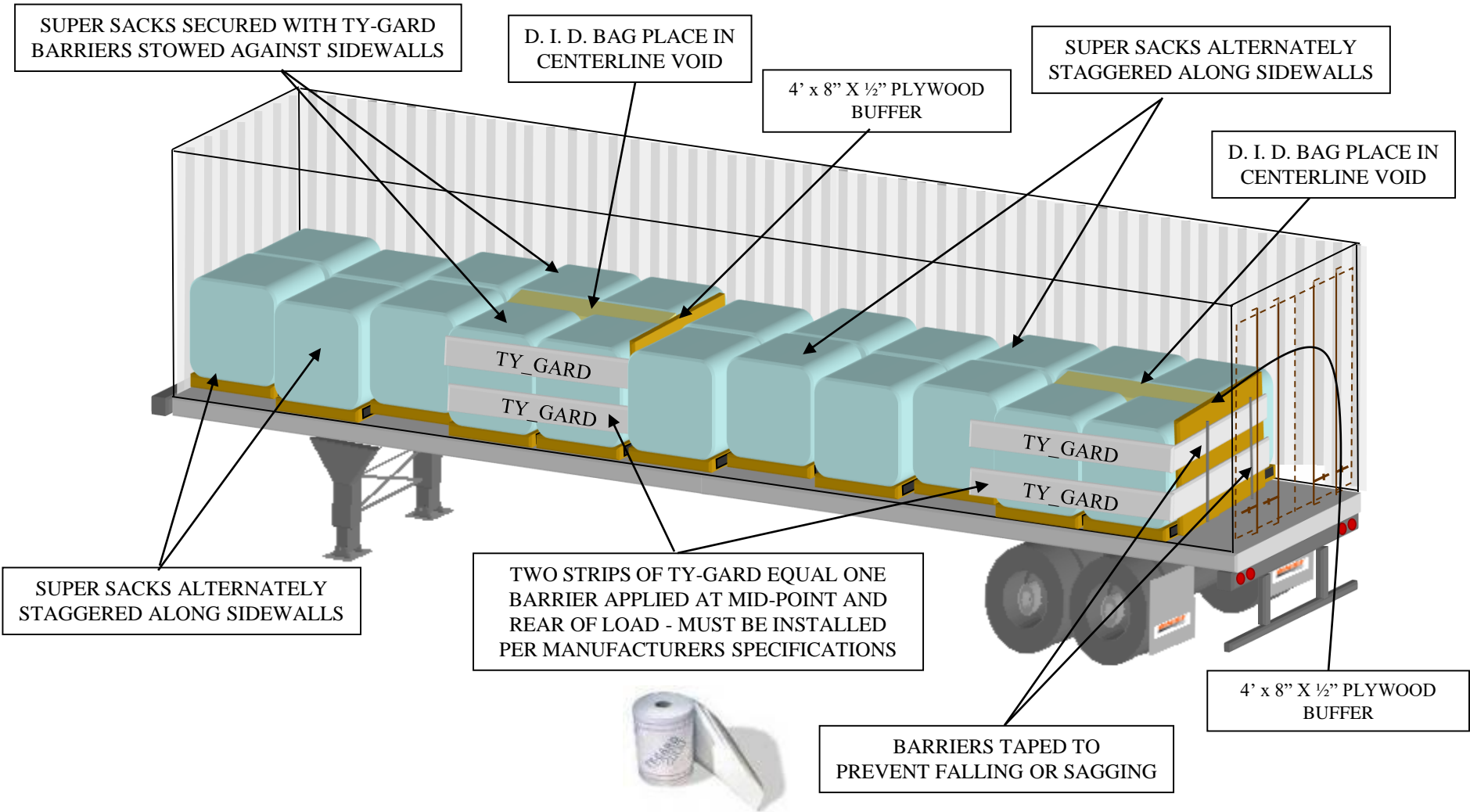
Apply two 15" wide strips to the sidewalls with an adhesive strip at least 60" long and located at least 36" back from the face of the cargo. Follow manufacturer's instructions for application.

Two strips of Ty-Gard / Ty-Patch equals one barrier; two barriers per shipment.

Tape barriers into place to prevent barriers from sagging/falling if they become slack in transit.

Leave approximately 24" space between the rear of the load and the equipment doors.

PALLETIZED SUPER SACKS ALTERNATELY STAGGERED SECURED WITH TY-GARD



LTL (Less Than Trailer Load) (Loading Techniques)



The securement methods are intended for the safe transit of trailer/container from origin to destination, and prevention of cargo and equipment damage.

Less-Than-Trailer Load (LTL) – Load Planning

Inspect cargo prior to loading into trailer or container. Do not load damaged freight. Evenly distribute the weight of load from side-to-side and end-to-end in equipment. The cargo should also be loaded to a uniform height, insofar as the cargo permits. Generally, light weight cargo should be loaded on top of heavy weight cargo, with layer separators utilized as needed. Load like-sized shipping packages and containers in stacks. Use divider sheets between stacks of different size, type or density packages and containers. Provide a stable base for all cargo, both palletized and individual pieces of freight.

Place shipping packages and containers in the position to best utilize the shipping containers' inherent strength. Load longest dimension of narrow-based items longitudinal of equipment.

Fill all longitudinal space with cargo and dunnage (filler) material, or appropriately block and brace, unless loaded to a specific method.

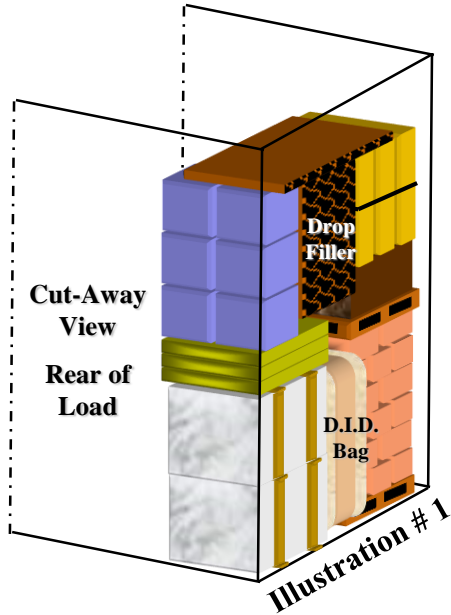
Plan the load to minimize lateral void space. Use appropriate bracing or dunnage (filler) material to maintain vertical alignment and prevent lateral movement.

In manually loaded shipments, use bonded-block patterns for fiberboard shipping containers. Load cylindrical shaped items such as pails, drums or rolled paper in a recessed or in-line load pattern. Load pails, buckets and small drums of liquids or solids to prevent shifting against other cargo. Consider a plywood separator between these items and other cargo in order to prevent crushing, puncturing or leaking of products.

Handle and load all freight according to the shipper's printed directions such as "This Side Up," "Do Not Drop," "Clamp Here," etc.

Segregate irregular items from remainder of cargo using blocking and bracing and/or separators and dividers.

LTL SHIPMENTS



Load heavier rigid type cargo on bottom, with lighter more easily damaged type cargo on top. Palletize and unitize cargo whenever possible and maintain product alignment during the warehousing and shipping cycle.



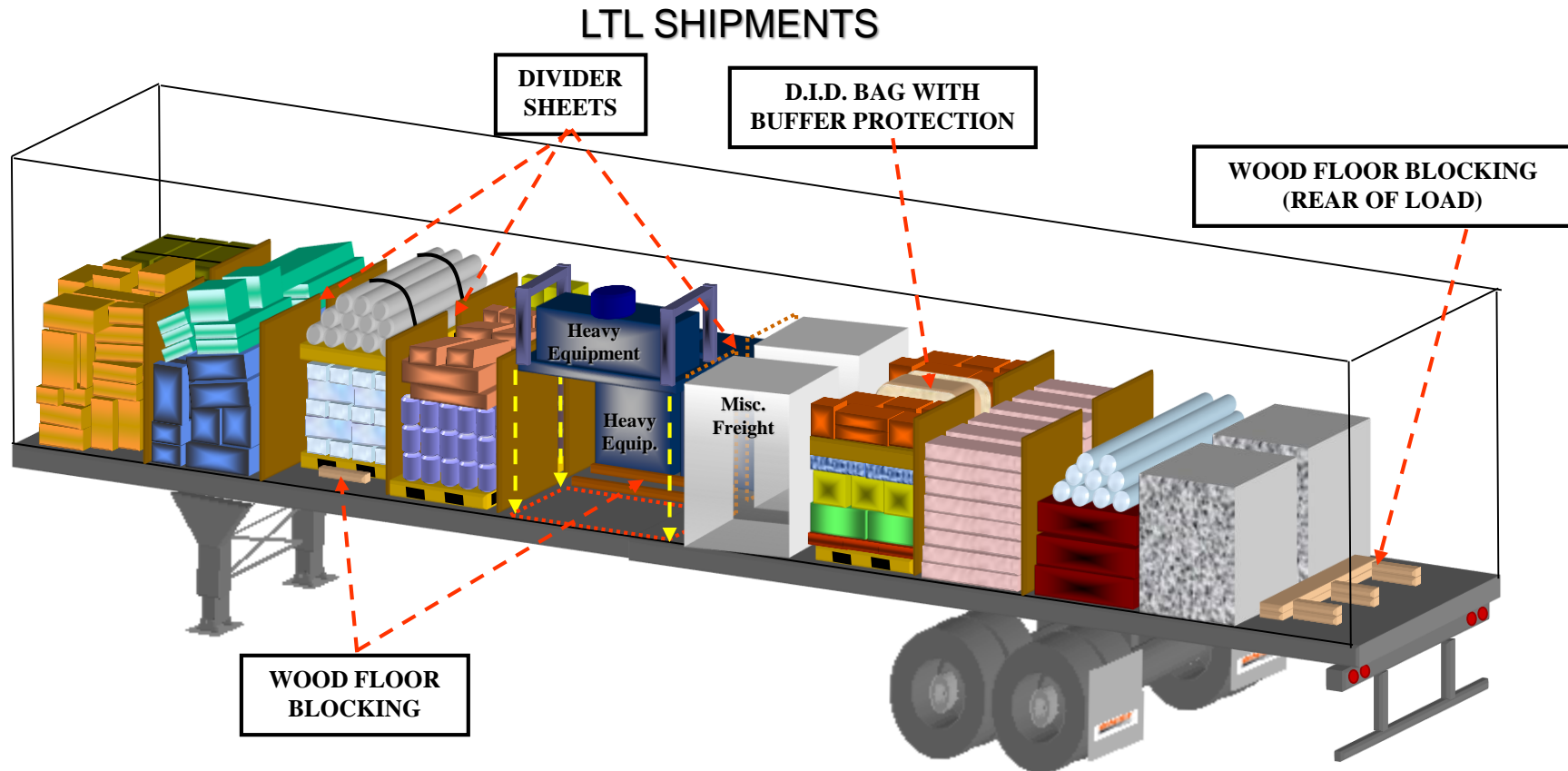
Segregate cargo of irregular heights, shapes and weights with sufficient strength divider sheets.



Evenly distribute weight of load from side to side and nose to rear to a uniform height of cargo insofar as cargo permits. Fill all void space with cargo or void filler material in order to prevent shifting.

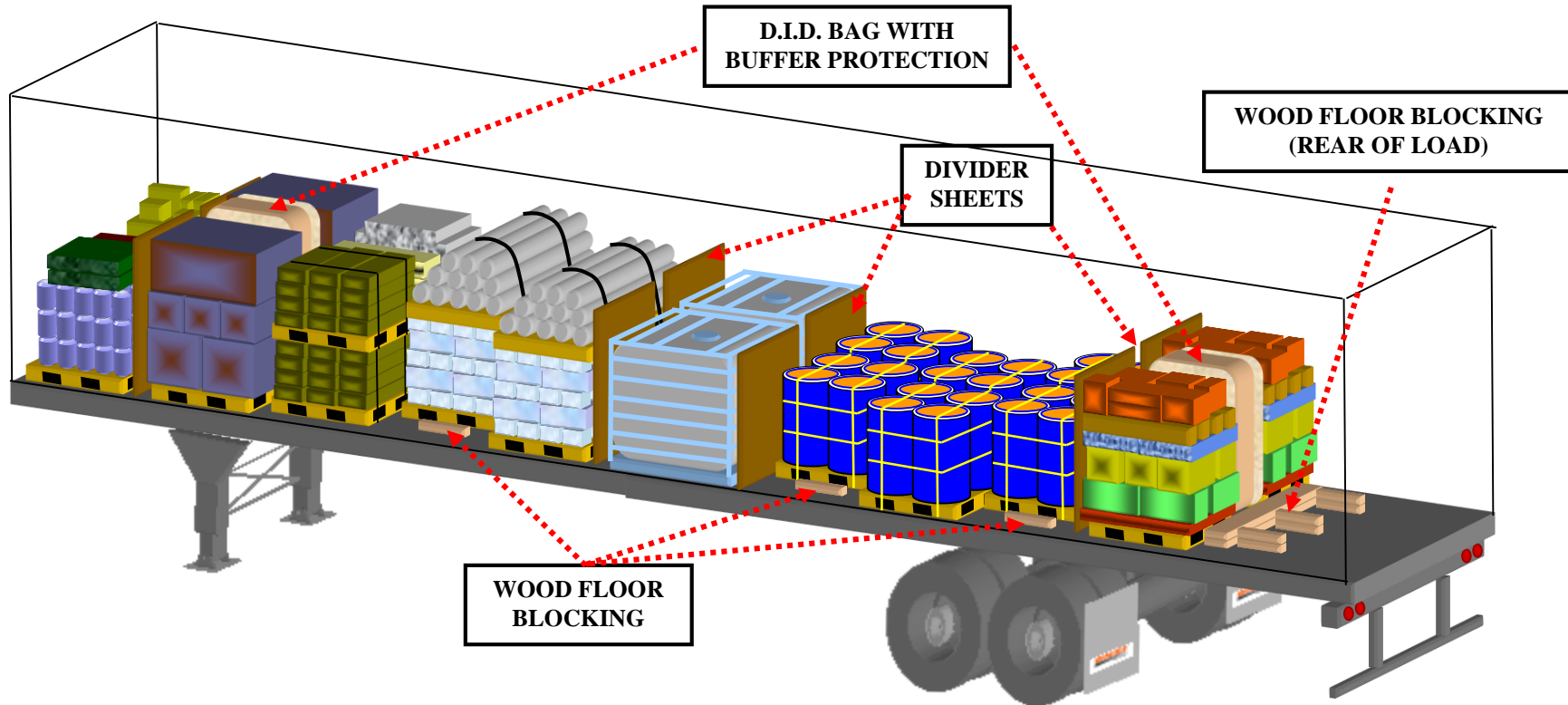


Illustration # 4



BLOCKING/BRACING OF INTERMODAL SHIPMENT

- 1.) Evenly distribute weight of load from side-to-side and nose-to-rear to a uniform height of cargo insofar as the cargo permits. Keep load tight nose-to-rear and side-to-side. Fill all longitudinal and lateral space with cargo or with cargo and buffer material, or block and brace.
- 2.) Position the cargo in a manner that offers the greatest protection, giving consideration to the weight and character of the packages assembled in building up the load. Generally load heavier cargo in lower layers and lighter cargo in the top layers. Provide a stable base for all cargo.
- 3.) Use divider sheets between different size containers or different type of cargo to help prevent cargo damage. When needed, utilize layer separators to prevent top-layer pallet contact with bottom-layer damage-sensitive cargo.
- 4.) **CFR Title 49 Sec. 174.55:** Each package containing a **Hazardous Material** must be loaded so that it cannot fall or slide and must be safeguarded in such a manner that other freight cannot fall onto or slide into it under conditions normally incident to transportation. When this protection cannot be provided by using other freight, it must be provided by blocking and bracing.

LTL SHIPMENTS**BLOCKING/BRACING OF INTERMODAL SHIPMENT**

- 1.) Evenly distribute weight of load from side-to-side and nose-to-rear to a uniform height of cargo insofar as the cargo permits. Keep load tight nose-to-rear and side-to-side. Fill all longitudinal and lateral space with cargo or with cargo and buffer material, or block and brace.
- 2.) Position the cargo in a manner that offers the greatest protection, giving consideration to the weight and character of the packages assembled in building up the load. Generally load heavier cargo in lower layers and lighter cargo in the top layers. Provide a stable base for all cargo.
- 3.) Use divider sheets between different size containers or different type of cargo to help prevent cargo damage. When needed, utilize layer separators to prevent top-layer pallet contact with bottom-layer damage-sensitive cargo.
- 4.) **CFR Title 49 Sec. 174.55:** Each package containing a **Hazardous Material** must be loaded so that it cannot fall or slide and must be safeguarded in such a manner that other freight cannot fall onto or slide into it under conditions normally incident to transportation. When this protection cannot be provided by using other freight, it must be provided by blocking and bracing.

SECTION VIII



Hazardous Materials

Hazardous Materials and Restricted Commodities

This publication does not include loading diagrams for hazardous materials or other restricted commodities, as defined by the [BNSF Intermodal Rules and Policies Guide \(IRPG\)](#) located on-line at www.BNSF.Com. Hazardous materials or restricted commodities cannot be tendered unless the following provisions are met:

SHIPMENT REQUIREMENTS

1. A special price authority for the restricted shipments must be established and provided to BNSF on the shipping instructions. (See the Price Authorities Application Section of the IRPG.)
2. The provisions or restrictions stated for restricted shipments must be followed.
3. Loading patterns and procedures recommended by BNSF's Load And Ride Solutions (LARS) must be utilized. Regardless of commodity or equipment, the cargo weight must be distributed evenly over the entire floor surface with no more than 25,000 pounds in any ten (10) linear feet or 2,500 pounds per linear foot on the equipment floor.
4. All shipping instructions must be complete, proper and declare the actual restricted commodity description (proper shipping name) and accurate applicable STCC, in addition to other shipping instructions requirements. Any type of FAK commodity description or FAK STCC is not allowed for restricted commodities. (See the Shipping Instructions Section.) Incomplete or improperly described shipping instructions or information for restricted shipments will incur the charges as stated in the Restricted Charges and Liability Section.

A complete list of restricted commodities is available in an appendix of the IRPG.

For assistance in determining proper securement for such commodities, please contract your local Load And Ride Solutions Manager or call 1-800-333-4686 for assistance.